

70-9131 RKPK28 Prototype Project PCB Kit Component List and Instructions

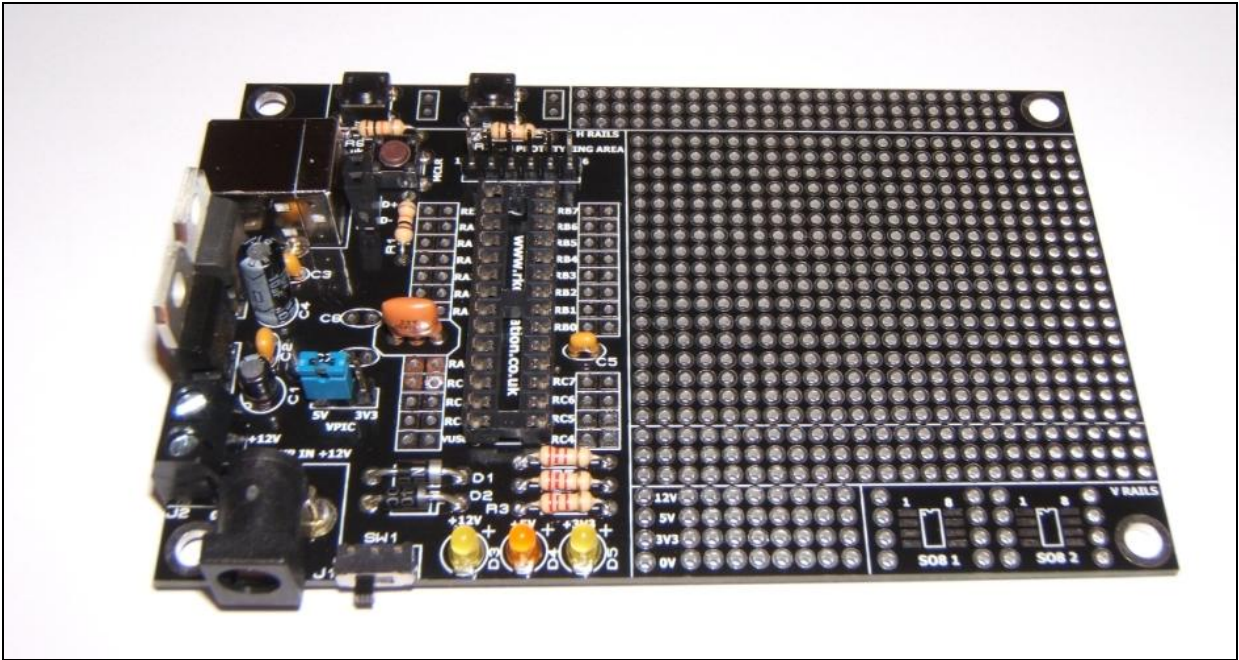

Constructed PCB

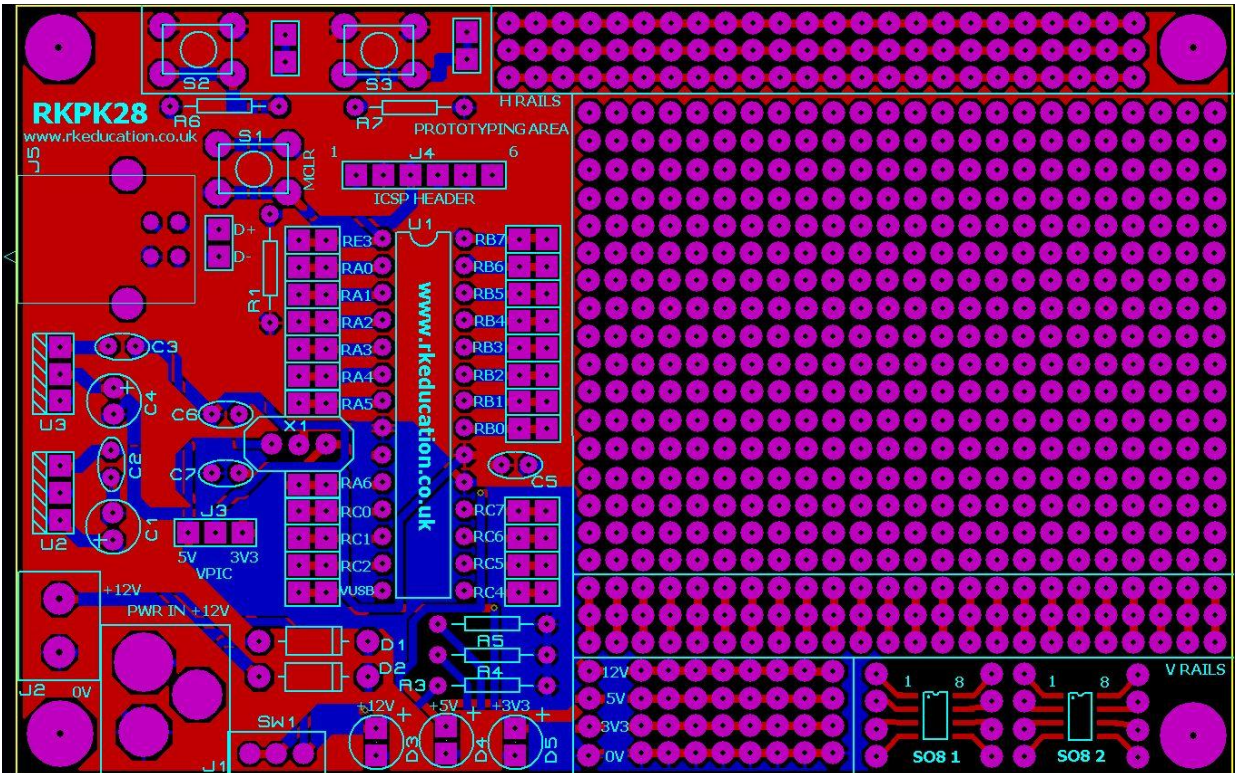

PCB Layout

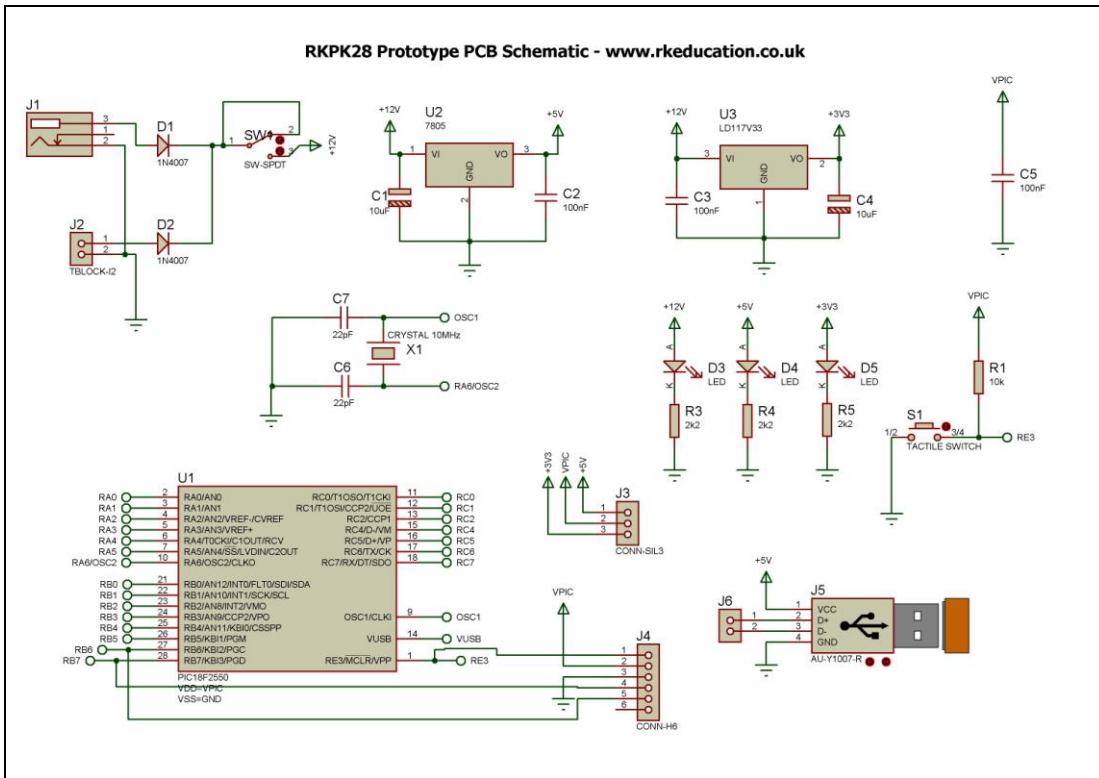

Schematic 1

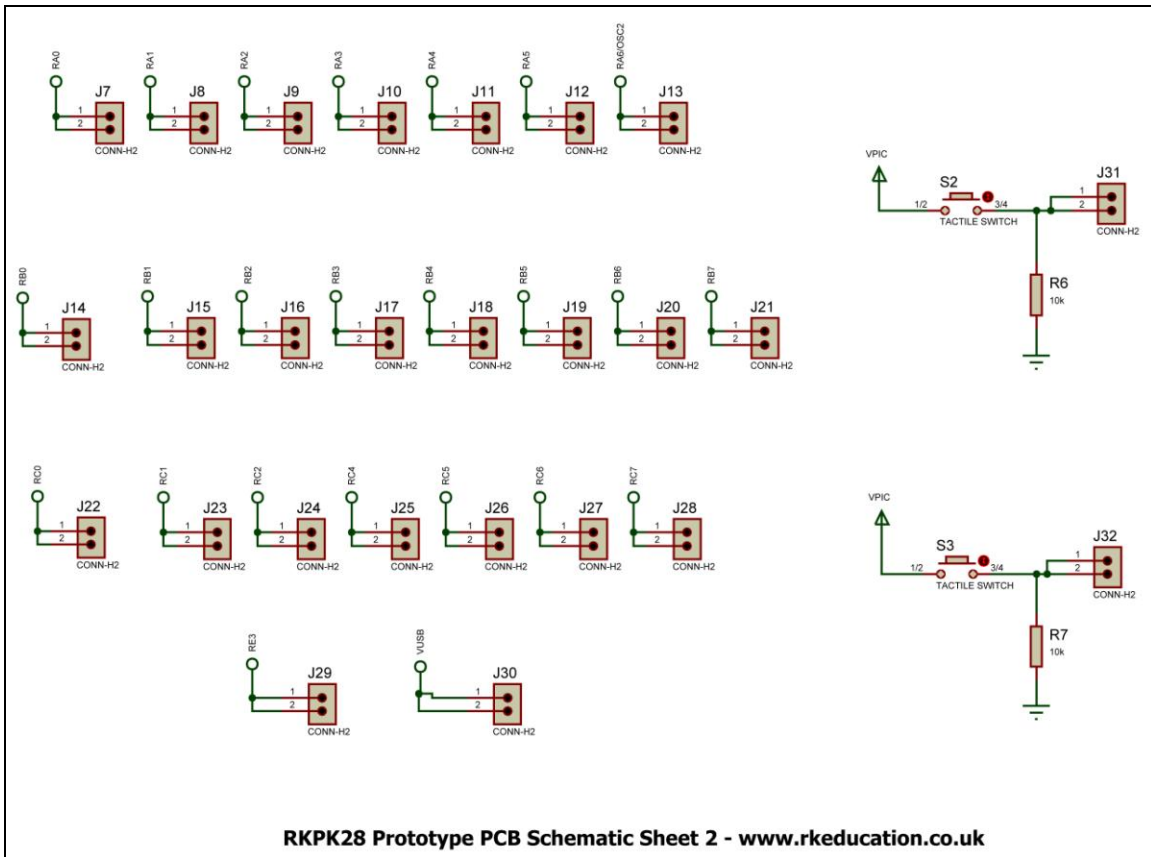

RKPK28 Prototype PCB Schematic Sheet 2 - www.rkeducation.co.uk

Schematic 2

Description

The RKPK28 prototype project PCB has been designed to use 28 pin PIC microcontrollers such as the PIC18F2550 and PIC18F27J53.

- Software is downloaded from a PC into the microcontroller via a PicKit programmer from Microchip
- A USB socket is included
- The clock reference is from a ceramic resonator or crystal
- All input and output pins have a PTH
- A large prototyping area
- 2 tactile switches available for prototyping
- Power rails on the prototyping area
- Powered from a terminal block or DC power socket
- +12VDC, +5VDC and +3V3 regulated outputs
- 3 LEDs used to indicate power – +12V, +5V and +3V3
- Power switch and LED power indicator

Component List

J1 – 2.1mm DC socket

J2 – 2 way 5mm pitch terminal block

J3 - 3 way header plug

J4 - 6 way header plug

J5 - PCB mount USB socket - B type

C1, C4 – 10 μ F electrolytic capacitor 16V DC

C2, C3, C5 – 100nF multilayer ceramic capacitor

C6, C7 - Capacitors for crystal oscillator, please use value specified for the chosen PIC

D1, D2 – 1N4007

D3, D4, D5 – 3mm LEDs (power indicators)

R1, R6, R7 – 10k Ω ¼ watt resistor (brown black orange)

R3, R4, R5 – 2.2k Ω ¼ watt resistor (red red red)

S1, S2, S3 – 6mm tactile switch

SW1 - Ultra miniature slide switch for power switch

U1 – 40 way DIP socket with microcontroller e.g. PIC18F2550

U2 – 7805 voltage regulator TO220 package

U3 - LD1117V33 voltage regulator TO220 package

X1 – Ceramic resonator or crystal oscillator

When constructing always start with the components that have the lowest profile and work high, for example start with the resistors and end on the 7805 voltage regulator.

Instructions

The PCB has been designed to use PIC microcontrollers e.g. PIC18F2550, PIC18F2553, PIC18F27J53 for instructions on how to use your chosen PIC please see the appropriate website.

Connecting Power

The power is connected to the terminal block marked PWR IN, the 0V input, usually black is put in the lower terminal and the +VE, usually red, is put in the upper terminal, power can also be supplied via the 2.1mm DC socket, a regulated 12V DC 1A power supply should be used. The circuit incorporates a 7805 and a LD1117V33 voltage regulator. A heat sink may need to be added to the voltage regulators if a high current is required.

A power switch has been included and is labelled SW1.

Downloading software

Once the software has been written using the PIC Programming Editor (or equivalent) it can be downloaded into the PIC. This is downloaded using a Pickit programmer or equivalent. Insert the programmer into the ICSP header and activate the program function in your Programming Editor. If all goes well it will tell you the program download was successful. There are many different programmers that can be used with this PCB, it is recommended that a Microchip programmer such as a Pickit2 or Pickit3 be used, for details on how to use your chosen programmer please consult the manufacturer's instructions.

Using the prototype area

Using the prototype area is simple and how it is used is dependent on what is being done. Access to all of the pins of U1 is gained by through holes near the pins of U1, simply connect using jumper wires. The bottom 4 rows of the prototyping area are power rails and are clearly marked on the PCB.

RKPK28 Prototype PCB Schematic - www.rkeducation.co.uk

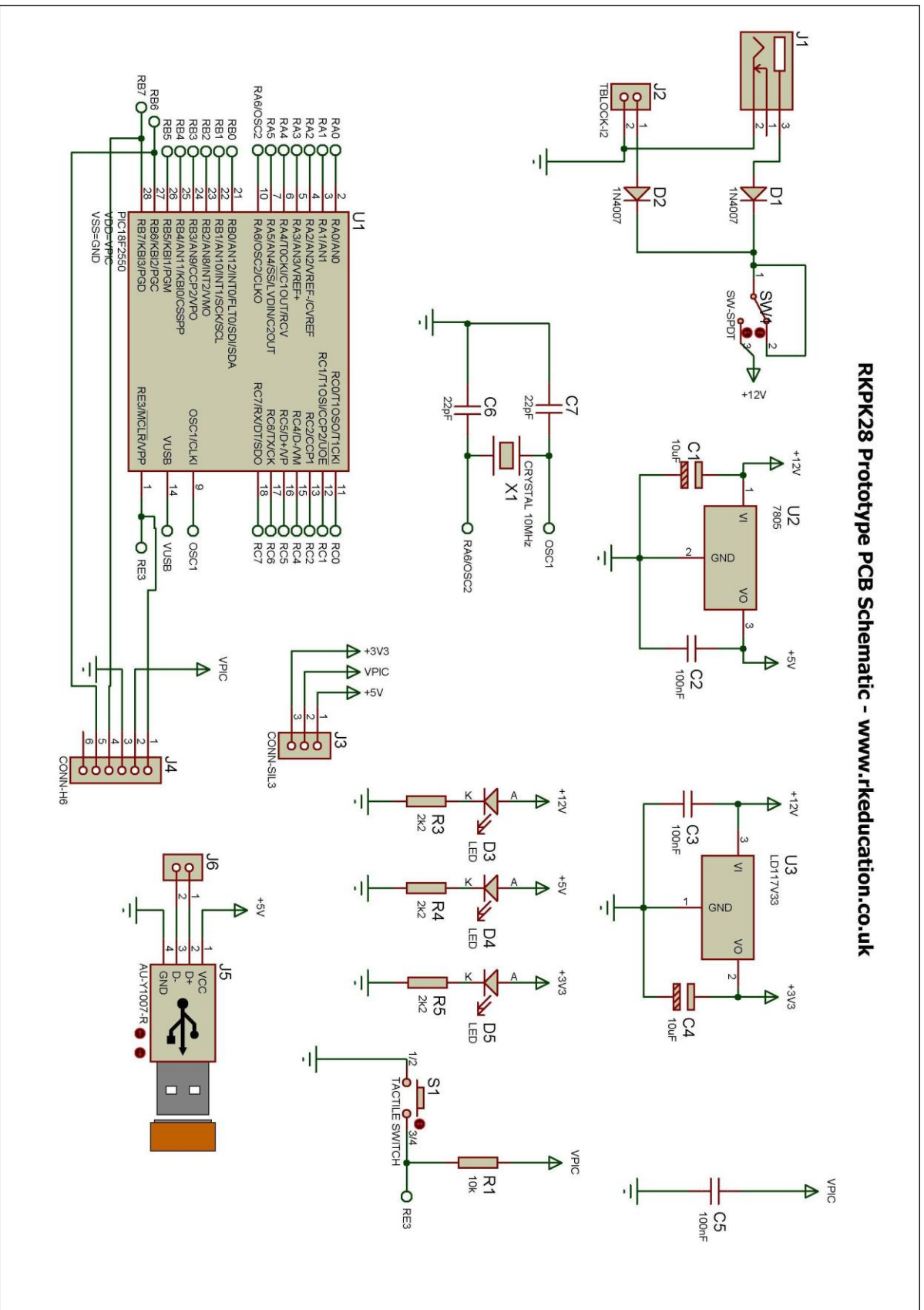

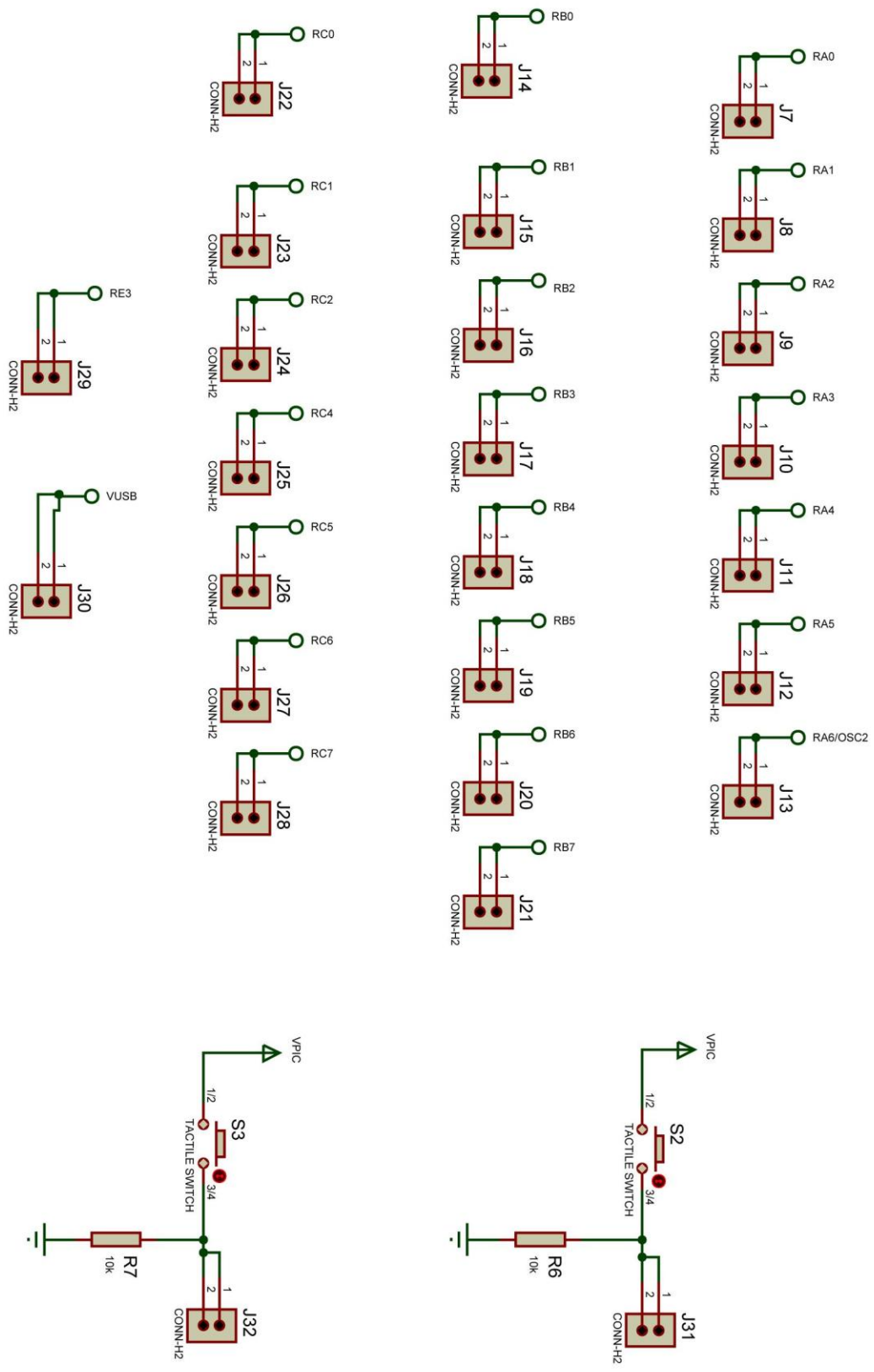

RPKP28 Prototype PCB Schematic Sheet 2 - www.rkeducation.co.uk