

70-9136 Shield L293D and Servo PCB Kit Components List and Instructions

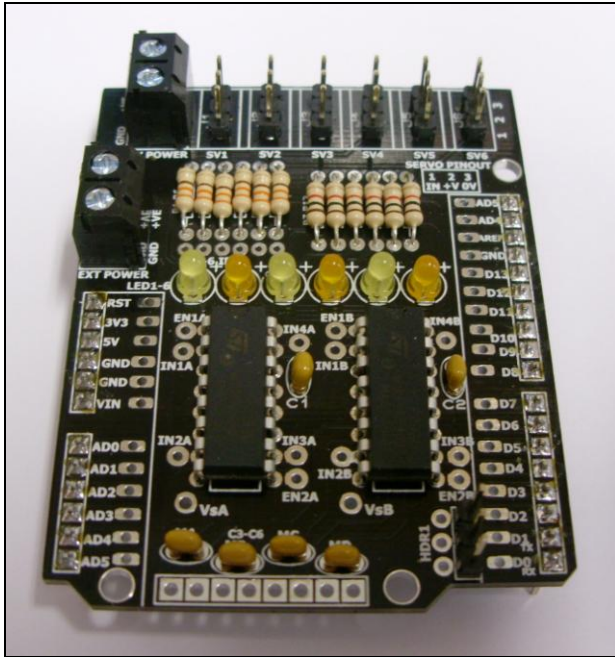

Constructed PCB

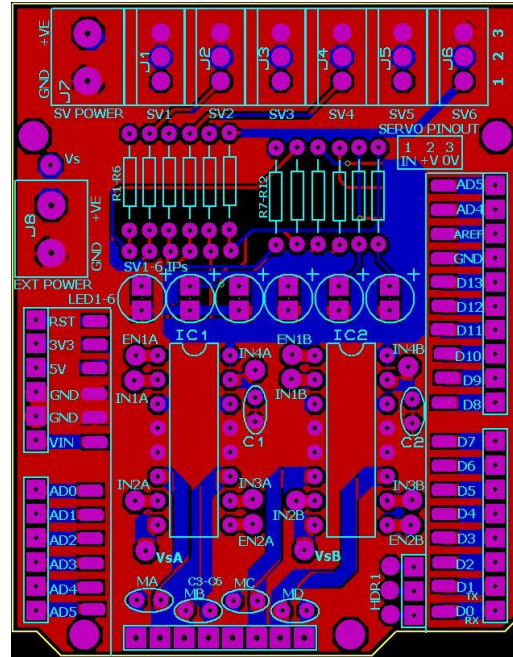

PCB layout

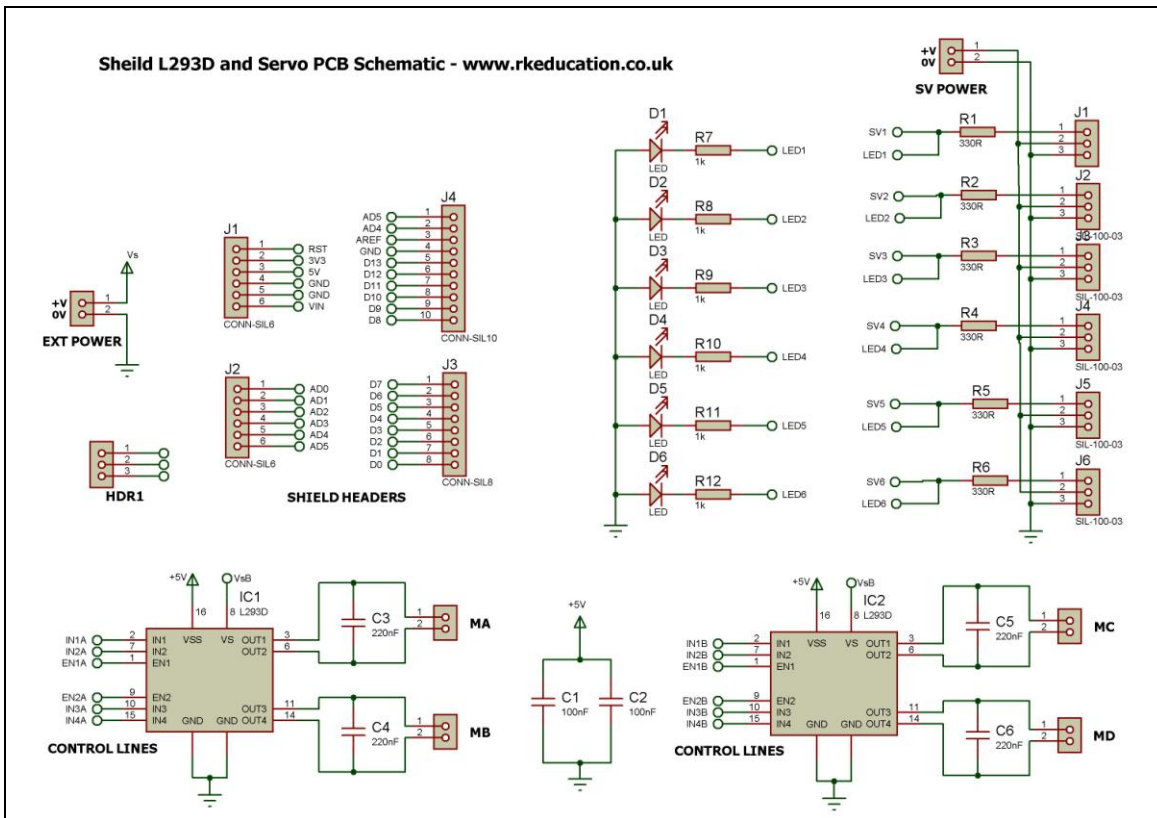

Schematic Diagram

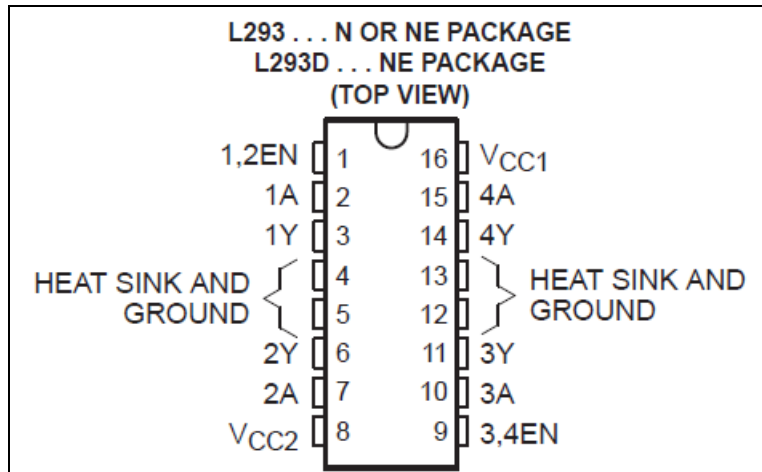

L293D Pinout

Description

The Shield L293D and Servo project PCB has been specifically designed to use the L293D H-Bridge chip and is great for interfacing with shields that use PIC and Atmel microcontrollers such as the Arduino, PICAXE and Genie.

- A low cost method of producing high power and DC motor projects
- Includes 2x L293D ICs
- Includes 6x servo control headers
- Can be interfaced to various microcontrollers and ICs such as PIC, ATMEL etc
- The control/interface lines are accessible with plated through holes around the L293D ICs
- Great for DC motor control projects including vehicles and robots
- Can drive 2 DC motors at 600mA or 1 at 1.2A
- Motors are reversible
- Manufactured using a double sided professional PCB
- Compact design

Component List

BAT and PWR SW - 2 way 5mm pitch terminal blocks for power supply and power switch

2x 2 way 5mm terminal blocks

7x 3 way header plugs

2x 6 way shield header sockets

1x 8 way shield header socket

1x 10 way header socket

C1, C2 - 100nF multilayer ceramic capacitor

C4 to C6 - 220nF multilayer ceramic capacitor

6x 3mm LEDs

R1 to R6- 330Ω ¼ watt resistor (orange orange brown)

R7 to R12- 1kΩ ¼ watt resistor (brown black red)

Instructions

This PCB has been designed to be used with shields. For information on how to use shields please visit an appropriate website such as the Arduino forum.

The PCB will need to be interfaced to an appropriate MCU such as an Atmel/Arduino or PIC/PICAXE. For guidance on using your chosen MCU please visit an appropriate forum.

For detailed information on the L293D dual h-bridge driver please see the appropriate datasheet.

When constructing PCBs it is advisable to start with the components with the lowest profile, for example resistors.

Connecting Power

There are 3 power supply considerations with this PCB.

1. Power from a shield base
2. Power for the L293Ds
3. Servo power

1. Power for the shield is supplied via the shield headers, plated through holes with labels are available for linking.

2. The terminal block EXT POWER has been provided to allow the user to supply the output power to the L293D (pin 8) from an external source. Pin 8 on the L293D ICs have plated through holes to allow the user to use the most appropriate power supply for their needs. It is possible to use either the external terminal block or shield headers for output power, simply use links as required.

3. The terminal block marked SV POWER has been provided to allow the user to supply the power for the servo outputs. The GND pin is connected to PCB GND and is also connected to the top layer power plane. The +VE pin is connected to pin 2 of all of the servo output headers. For the power requirements of your chosen servo please refer to the technical information of the particular servo.

Using the L293D

The L293D is an h-bridge drive chip, for more information on this chip please refer to a specific [datasheet](#) for this device.

Each L293D powers two motors at up to 600mA each or 1 motor up to 1.2A, motors are reversible. The outputs to the motors are clearly marked **MA, MB, MC** and **MD**. The motors are controlled by sending appropriate output signals from the microcontroller to the L293D. The L293D must be enabled and inputs marked **EN1A, EN1B** and **EN2A, EN2B** are used, to enable send a logic 1 to the appropriate enable input. The chip may be permanently enabled if required. It is also possible to control the speed of the motors. This is normally achieved by using a PWM output from the MCU. To do this with your chosen MCU please refer to the appropriate forum.

To control motors use the following as a guide:

Microcontroller		L293D	
Pin x	to	pin 7	MA
Pin x	to	pin 2	MA
Pin x	to	pin 15	MB
Pin x	to	pin 10	MB

Both inputs low	- motor stop
First output high, second output low	- motor forward
First output low, second output high	- motor reverse
Both inputs high	- motor stop

To attach a motor simply solder the flying leads from the motor into the appropriate terminals on the header.

Please note that if you use the L293D near to its maximum limits the device may become hot and then a heat sink will need to be used.

Using the servos

To use the servos connections will need to be made from the shield interface headers to the servo control inputs labelled SV1 to 6.

The servos will also need to be powered, there is a terminal block for this purpose but it is also possible to power the servos from the PCB if required by using a link between the shield interface headers and the terminal block SV POWER. Follow the technical guidance for your servo when selecting the power supply and the voltage.

A servo has 3 wires and usually a header socket, this socket interfaces to the header plugs on the PCB. The 3 wires are 0V, +VE and control signal and the PCB is labelled as such, take care when attaching a servo to the header plugs. The control signal wire is used to communicate the angle. The angle is determined by the duration of a pulse that is applied to the control wire. This is called Pulse Coded Modulation. The servo expects to see a pulse every 20 milliseconds (0.02 seconds). The length of the pulse will determine how far the motor turns. A 1.5 millisecond pulse, for example, will make the motor turn to the 90 degree position (often called the neutral position). If the pulse is shorter than 1.5ms, the motor will turn the shaft to closer to 0 degrees. If the pulse is longer than 1.5ms, the shaft turns closer to 180 degrees.

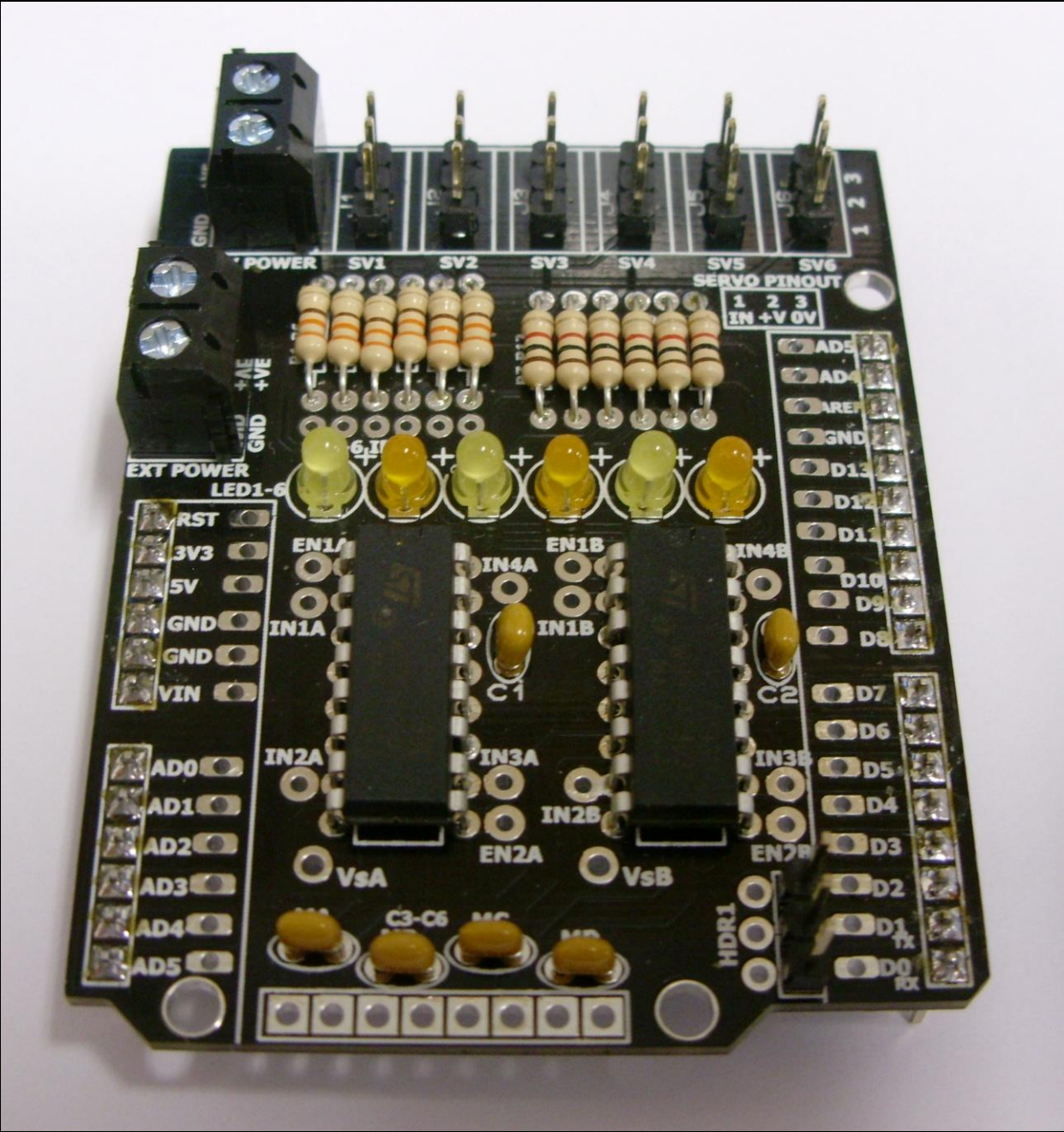

Shield L293D and Servo PCB Schematic - www.rkeducation.co.uk

