



# 7.6mm 3 Chip Superflux Pure Green LED 12000MCD

Order code: **72-9656**

MPN: OSG583Z2C1P

## Features:

- High Luminous Super Flux Output
- Superior Weather-resistance
- UV Resistant Epoxy
- Long Lifetime Operation
- Water Clear Type

## Applications

- General Purpose Indicators
- Small Area Illuminations
- Back Lighting
- Other Lighting



## Outline dimensions:

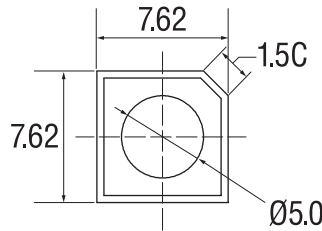

1, 4 → → → 2, 3

Unit: mm  
Tolerance:  $\pm 0.20$ mm  
unless otherwise stated  
1, 4: Anode  
2, 3: Cathode

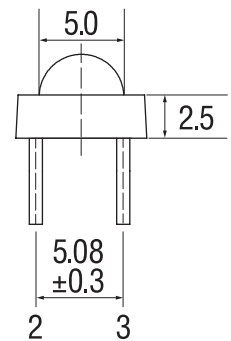
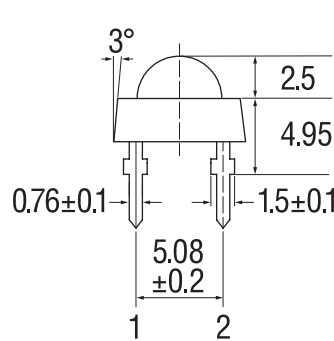

## Absolute maximum rating (Ta=25°C)

Item	Symbol	Value	Unit
DC forward current	$I_F$	30	mA
Pulse forward current*	$I_{FP}$	100	mA
Reverse voltage	$V_R$	15	V
Power dissipation	$P_D$	324	mW
Operating temperature	$T_{opr}$	-30 to +85	°C
Storage temperature	$T_{stg}$	-40 to +100	°C
Lead soldering temperature	$T_{sol}$	260°C/5sec	-

\*Pulse width max. 10ms. Duty ratio max. 1/10

## Electrical - Optical characteristics (Ta=25°C)

Item	Symbol	Condition	Min.	Typ.	Max.	Unit
DC forward voltage	$V_F$	$I_F = 20$ mA	8.4	9.3	10.8	V
DC reverse current	$I_R$	$V_R = 15$ V	-	-	10	$\mu$ A
Dominant wavelength*	$\lambda_D$	$I_F = 20$ mA	520	525	530	nm
Luminous flux*	$\Phi_V$	$I_F = 20$ mA	8	10	-	lm
Luminous intensity*	$I_V$	$I_F = 20$ mA	10000	12000	-	mcd
50% Power angle	$2\theta_{1/2}$	$I_F = 20$ mA	-	120	-	deg

\*1 Tolerance of measurements of dominant wavelength is +1nm  
\*2 Tolerance of measurements of luminous intensity is +15%  
\*3 Tolerance of measurements of forward voltage is  $\pm 0.1$ V

## Directivity:

