

NOTE: FINISH (PLATING THICKNESS IN MICRO-INCHES)
 1. BODY: BRASS PER JIS-C3604
 2. CONTACT: PH/BRONZE PER ASTM B196 UNS C17300
 3. INSULATION: TEFLON PER ASTM D1457 AND ASTM D1710
 4. CONNECTOR INTERFACE PER MIL-STD-348A
 5. PART TO BE CLEAN AND FREE BURRS
 6. GOLD PL 1-3 u" OVER NICKEL PL 70 u" min THICK OVER COPPER STRIKE

3	Insulator	Teflon	White
2	Contact	PH/Bronze	Gold
1	Body	Brass	Nickel
No	Description	Material	Finish

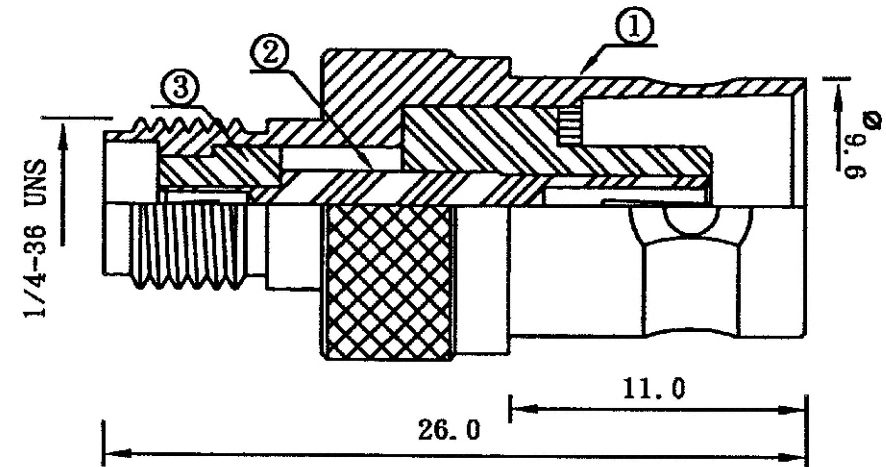

Artikelnummer **Artikeltext**
 730714 Adapter, SMA-Kupplung auf BNC-Kupplung