

|                     |                       |  |
|---------------------|-----------------------|--|
| Rating              | 10A 125V AC           | Mount Hole<br> |
| Contact R           | 50m ohm Max           |  |
| Insulation R        | DC 500V 100M ohm Min. |  |
| Dielectric Strength | AC 1000V 1 minute     |  |

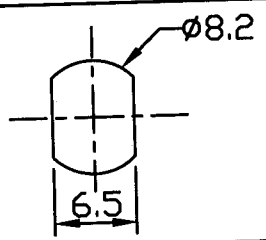

C1\WK12\R1\R1-9-0

|          |          |          |              |    |                                |            |      |
|----------|----------|----------|--------------|----|--------------------------------|------------|------|
| △        | 11/12/01 | 張曉斌      | 圖面整合修改       |    |                                |            |      |
| △        | Date     | Name     | Descriptions |    |                                |            |      |
| Drawing  | Check    | Approval | SCI No.      |    |                                | Model Name |      |
| 張曉斌      | 李作山      | 研發部      | Customer No. |    |                                | Model No.  | R1-9 |
| 11/12/01 | 11/13/01 | 李景雄      | Unit         | mm | SHIN CHIN INDUSTRIAL CO., LTD. |            |      |

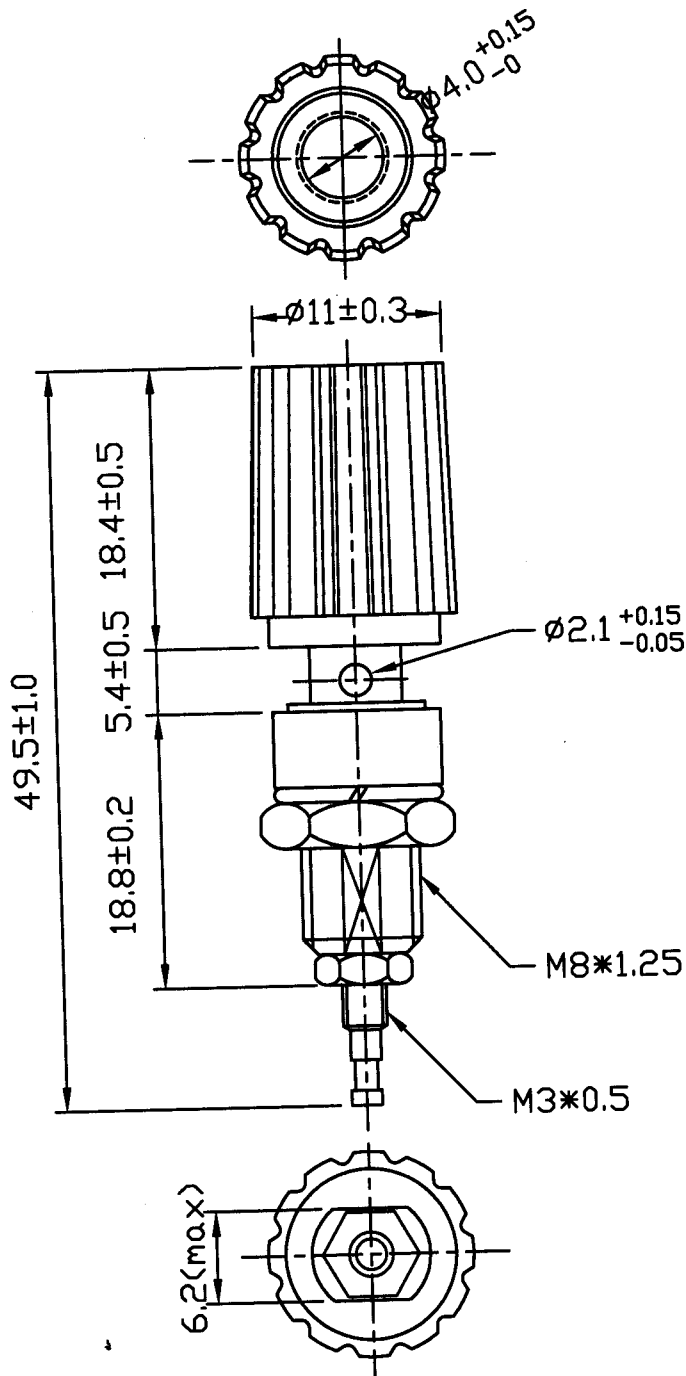
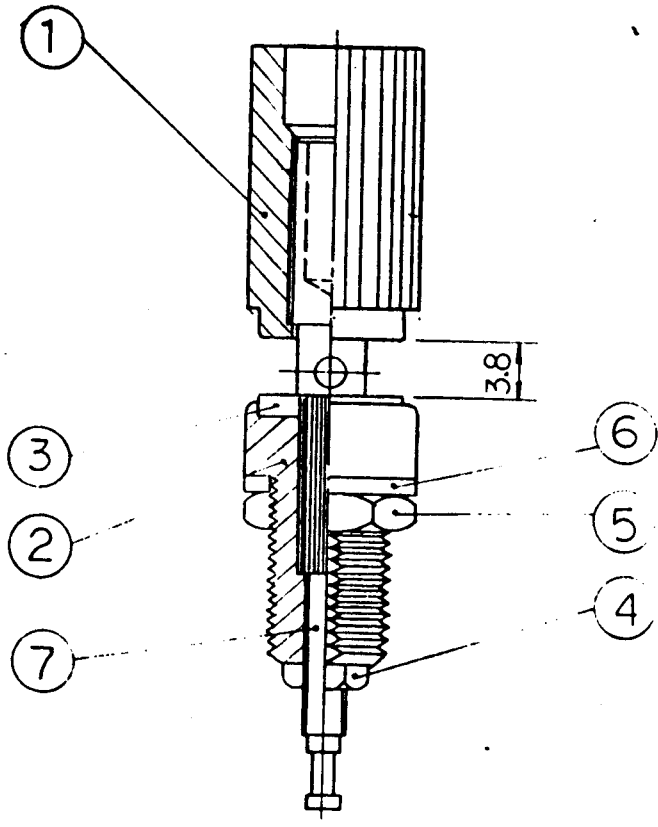

| 7  | Bushing        | 1    | Copper Alloy |            |            |        |
|----|----------------|------|--------------|------------|------------|--------|
| 6  | Washer Spring  | 1    | SWRH         | t=1.0±0.05 | Ni-Plating |        |
| 5  | Hexagon Nut    | 1    | Copper Alloy | t=3.0      | Ni-Plating |        |
| 4  | Contact Strip  | 1    | Copper Alloy | t=2.0      | Ni-Plating |        |
| 3  | Washer Locking | 1    | Copper Alloy | t=1.0      | Ni-Plating |        |
| 2  | Housing Down   | 1    | Nylon#6      |            |            |        |
| 1  | Housing Up     | 1    | PA6          |            |            |        |
| No | Description    | Q'ty | Material     | Spec       | Finish     | Remark |

|          |       |          |     |      |      |      |
|----------|-------|----------|-----|------|------|------|
| Spec-No. | R1-9  |          | No. | Note | Date | Name |
| Date     |       |          |     |      |      |      |
| Drawing  | Check | Approval |     |      |      |      |
|          |       |          |     |      |      |      |
| 9/18/11  |       | 8/12/97  |     |      |      |      |