

ISS SYMBOL		REVISIONS
		DESCRIPTION \ DATE

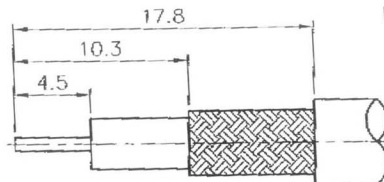

RECOMMENDED  
CABLE STRIPPING DIM'S  
(建議剝線尺寸)

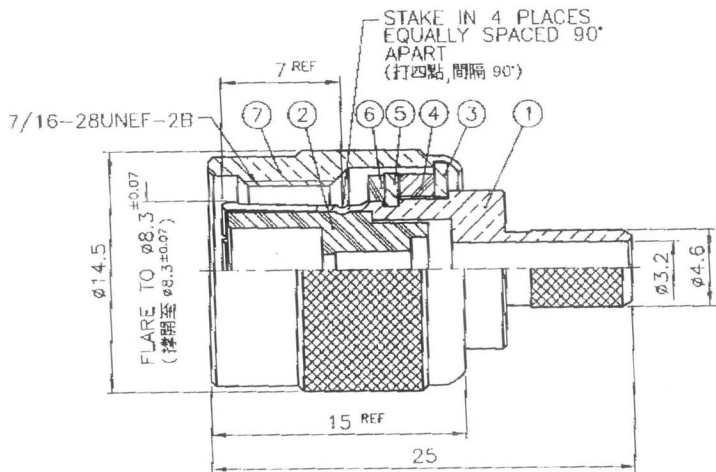
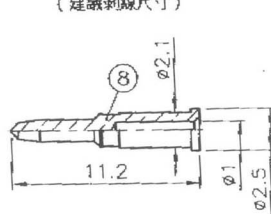

REMARK: RoHS REQUIREMENT APPLIED  
(符合 RoHS)

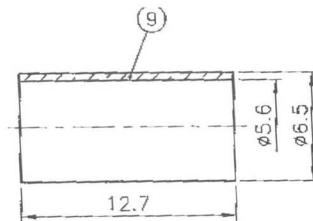

出圖  
94.12.27  
開發設計部



NOTES: FINISH (PLATING THICKNESS IN MICRO-INCHES)

1. BRASS PER QQ-B-626
2. NICKEL PL 70 MIN THICK OVER COPPER STRIKE
3. GOLD FLUSH OVER NICKEL PL 70 MIN THICK OVER COPPER STRIKE
4. BRASS JIS H 3250, C 2700

1. CRIMPED FERRULE  
HEX CRIMP SIZE .213"  
(套管壓著工具)
2. CRIMPED CONTACT PIN  
HEX CRIMP SIZE .068"  
(中心針壓著工具)

TOTAL P.01

DESCRIPTION	MATERIAL	FINISH	Q'TY	DRAWING NO.
FERRULE	NOTE 4	NOTE 2	1	C06-001N
CONTACT PIN	NOTE 1	NOTE 3	1	C01-002RGFD4
SHELL	NOTE 1	NOTE 2		
GASKET	RUBBER	RED		
C RING	SS41	NOTE 2		
WASHER	DELTRIN	NATURAL	1	H7401-BNDGA
WASHER	SS41	NOTE 2		
INSULATOR	DELTRIN	WHITE		
BODY	NOTE 1	NOTE 2		

DIMENSIONS ARE IN MILLIMETERS  
UNLESS OTHERWISE SPECIFIED  
TOLERANCES  
(一般公差)  
0.5~6 = ±0.2  
>6~30 = ±0.4  
>30~120 = ±0.6  
>120~315 = ±1  
>315~1000 = ±1.6  
ANGLES(角度) = 15°

PART NO.	
APPROVED	DATE
CHECKED	DATE
DRAWN	DATE

Teamsonic Industrial Co.,LTD e-mail: sales@teamsonic.com.tw
TITLE: TNC CRIMP PLUG (FOR RG-58/U)
DRAWING NO. R7401-BNDGA (BN 735833)
FILE NO. Z:\品檢圖\BJ74\BJ7401BNDGA-A1R