

NOTES:

1. Insulation: Glass Filled Nylon 9T UL94V-0, Color White
2. Contact : Brass
3. Plating : Selective Gold Flash over 50µ" Nickel
4. Shell Plating: Steel , 50µ" Nickel over 100µ" Cu
5. Packing: Tape & Reel

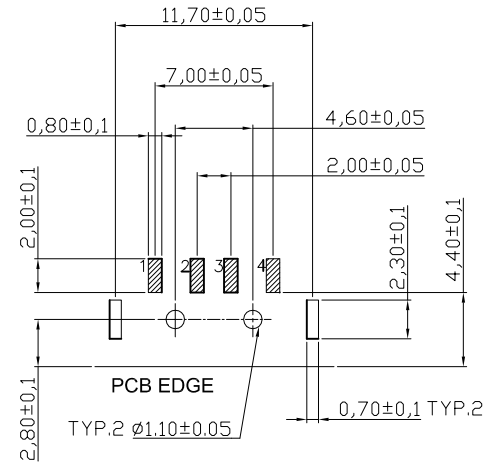

Recommended PCB Layout

RoHS compliant

Scale	1:1						Date	Name	Customer-No.
TOLERANCE							Drawn	25.03.2006	Hellwig
.X	±0.30						Approved	07.07.2009	Hellwig
.XX	±0.20								ASSMANN WSW-No.
.XXX	±0.10								A-USB A-LP-SMT-C
DIM	TOL	②	Update	07.07.2009	Dean	ASSMANN WSW components	Drawing-No.		
X.°	±1°						ASS 1452A CO		rev02
Angle	TOL	①	Drawn	25.03.2006	Hellwig		Replace		SHEET
UNIT	mm	Id.	Modification	Date	Name				1 / 2

1

2

3

4

5

6

7

1 2 3 4 5 6 7

A

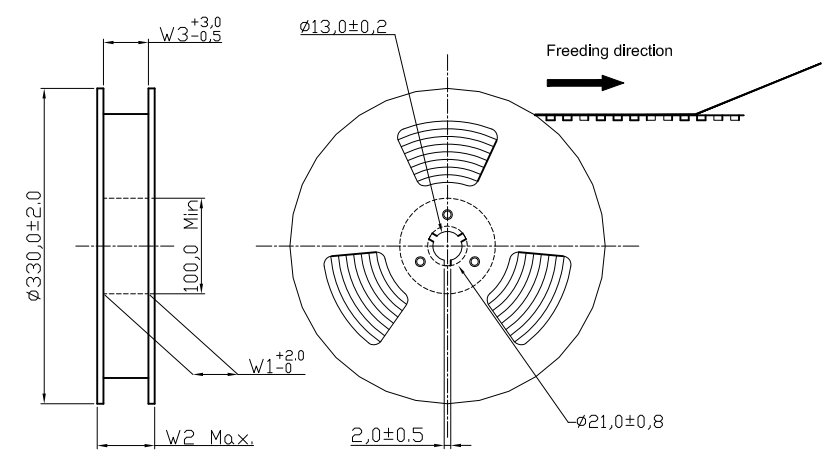

NOTES:

- 1.Reel Material: HIPS
- 2.Carrier Material : Black, Conduitive Ploystyrene Alloy
- 3.Cover Tape Material: Polyester
- 4.Cover Tape Peel Strength:0.1N-1.3N
- 5.Carrier camber is within 1 mm in 250 mm
- 6.All dimensions meet EIA-481-B requirements
- 7.Quantity:500 PCS/Reel

Dimensions					Packing (Reel/Caton)
E	F	W1	W2	W3	
44.0	40.40	44.5	50.5	44.5	5

B

C

D

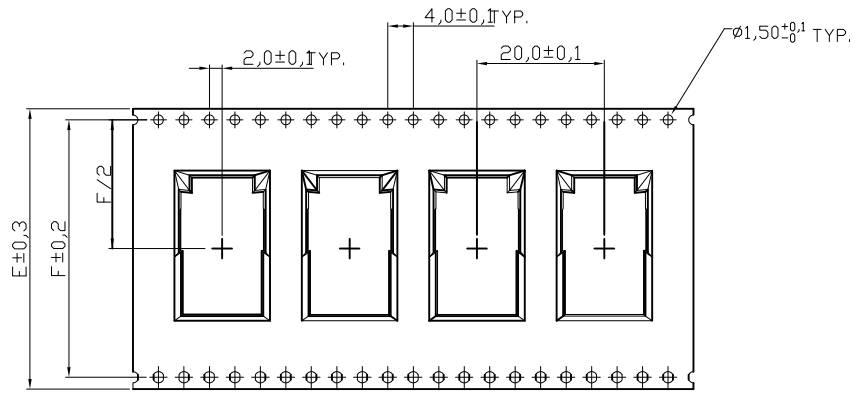
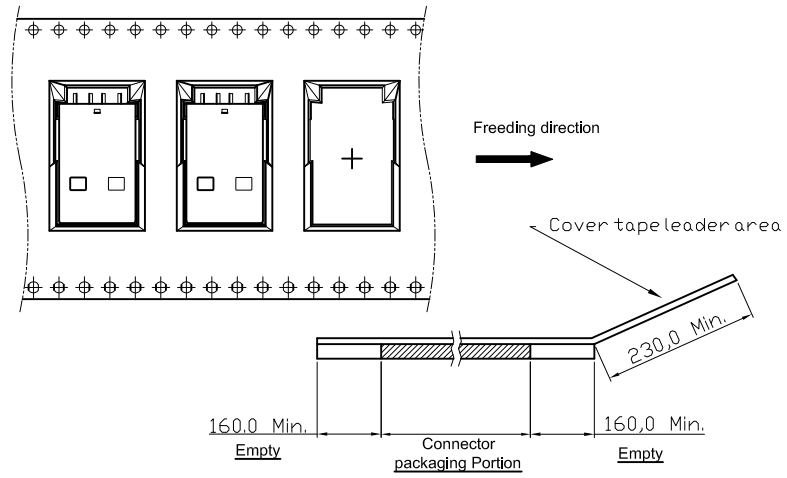

WIDTH: 44 mm Carrier

E

F

RoHS compliant

Scale	1:1					Date	Name	Customer-No.
TOLERANCE						Drawn	25.03.2006	Hellwig
.X	±X					Approved	07.07.2009	Hellwig
.XX	±X							
.XXX	±X							
DIM	TOL	②	Update	07.07.2009	Dean			
X.°	±1°							
Angle	TOL	①	Drawn	25.03.2006	Hellwig			
UNIT	mm	Id.	Modification	Date	Name			

Customer-No.	
ASSMANN WSW-No. A-USB A-LP-SMT-C	
Drawing-No.	rev02
ASS 1452A CO	SHEET 2 / 2

G

H

1 2 3 4 5 6 7