

### SPECIFICATIONS

**Current Rating:** 1.0 Amp

**Dielectric Withstand:** 1000V AC

**Insulator Resistance:** 5000 MΩ min.

**Contact Resistance:** 20mΩ Max.

**Operating Temperature:** -55°C to + 105°C

### MATERIALS

**Insulator:** Thermoplastic, UL94V-0  
Nylon-6T

**Contacts:** Copper Alloys

**All materials must be RoHS compliant.**

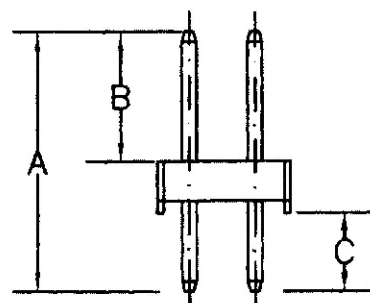
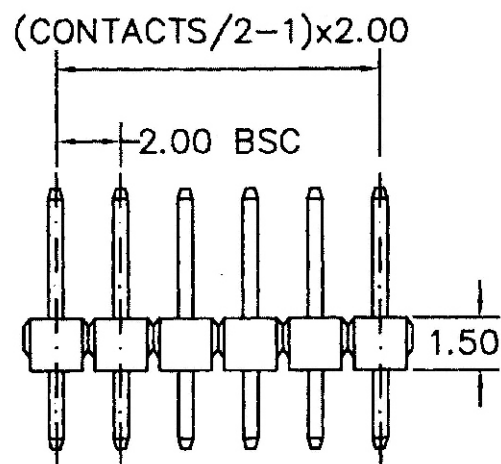

Datenblatt passend zu folgenden Artikelnummern

10120402