

<b>Order code</b>	<b>Manufacturer code</b>	<b>Description</b>
75-0378	R13-423L2 B/R RED	SPST LED TOGGLE SWITCH RED RC

	Page 1 of 2
The enclosed information is believed to be correct, Information may change without notice due to product improvement. Users should ensure that the product is suitable for their use. E. & O. E.	Revision A 20/02/2007

Rating	30A 12VDC	裝配孔 Mount Hole	線路圖 Circuit Structure
接觸電阻 Contact R	50m ohm Max.		ON
絕緣阻抗 Insulation R	DC 500V 100M ohm Min.		
耐電壓 Dielectric Strength	AC 1500V 1 minute		
動作特性 Circuit	3P SPST ON-OFF		
搬動力 Operation Force	450g $\pm$ 150g $\triangle$		

環境溫度 Operation Temperature	-20°C-85°C $\triangle$	$\triangle$
機械壽命 Mechanical Life test	6-10Cycls/Minute	6.000Cycles $\triangle$
電氣壽命 Electrical Life test	6-10Cycls/Minute	5.0000Cycles $\triangle$

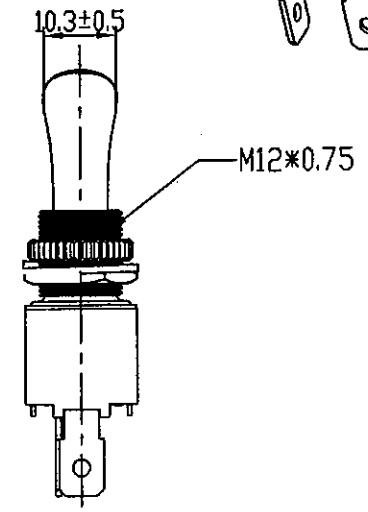
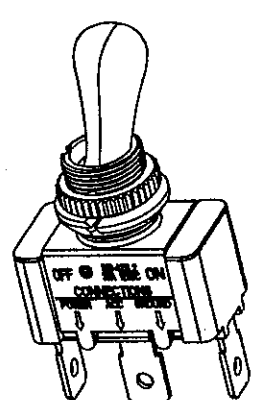
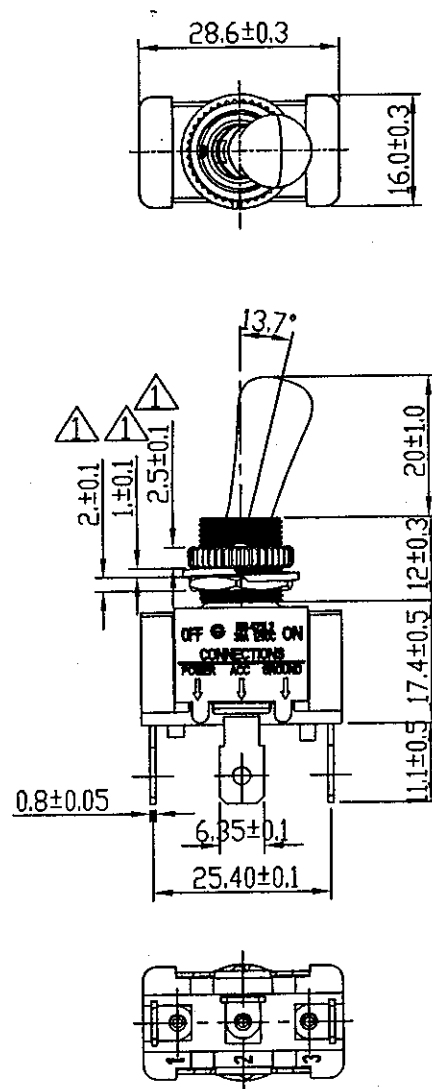

Descriptions:  
 1.LED發光手把排檔構造型  
 2.材質:參考目錄2-13

Customer No.	No.	Date	Name	Descriptions
SCI No. 1811366	$\triangle$	12/20/04	Paulong	增加搬動力: 450g $\pm$ 150g 環境溫度: -20°C-85°C
Model No. R13-423L2	$\triangle$	12/20/04	Paulong	增加尺寸標注 2.5 $\pm$ 0.1, 1.0 $\pm$ 0.1, 2.0 $\pm$ 0.1
Drawing	Check	Approval		
李寶龍				
12/15/04				