

## Arduino M95 GSM Shield

The Arduino M95 GSM Shield is helpful tool for those advanced hobbyists and professionals, who want to get familiar with GSM data/voice communication using their Arduino board. Please read the M95 Hardware design and M95 AT Command Set documentation first.

### 1. Hardware Requirements:

- valid SIM card - **(not supplied)**
- Arduino/Genuino UNO (ATMega 328P) or Mega (Atmega2560) - **(not supplied)**
- External power supply – **(not supplied)**

### 2. Technical requirements

- Operating voltage range: 6-12VDC
- Operating current: up to 2A DC during transmission bursts, make sure your power supply is sufficient for powering GSM module during these bursts

### 3. GSM module:

- M95 QUECTEL HW design  
[http://www.quectel.com/UploadImage/Downlad/M95\\_Hardware\\_Design\\_V1.3.pdf](http://www.quectel.com/UploadImage/Downlad/M95_Hardware_Design_V1.3.pdf)
- M95 AT Command set  
[http://www.sos.sk/a\\_info/resource/c/quectel/M95\\_ATC\\_V1.0.pdf](http://www.sos.sk/a_info/resource/c/quectel/M95_ATC_V1.0.pdf)
- RF connector – SMA female, telematic antenna is part of delivery, any GSM antenna with SMA connector can be used
- For GSM module FW update use JP4 connector (see schematic for pin assignment)

#### 4. Arduino M95 GSM Shield description

- LEDs: Red LED – Network Light

permanently OFF	M95 module is OFF
64 ms ON / 800 ms OFF	M95 is not logged in the network
64 ms ON / 2000 ms OFF	M95 is logged in the network
64 ms ON / 600 ms OFF	Ongoing GPRS data transfer

- Green LED: Shield Powered

#### 5. Connectors on M95 Shield:

Conn J1 (POWER)	Signal
PIN1	No connection
PIN2	No connection
PIN3	5VDC from Arduino board
PIN4	GND
PIN5	GND
PIN6	VIN – 6-12VDC from external power source

Conn J2 (ANALOG)	Signal
PIN1	No connection
PIN2	No connection
PIN3	No connection
PIN4	No connection
PIN5	No connection
PIN6	No connection

Conn J3 (Digital8_13)	Signal
PIN1	PWRKEY (default)
PIN2	EMERG (default)
PIN3	GSMON (must be HIGH to enable communication with M95)
PIN4	No connection
PIN5	No connection
PIN6	No connection
PIN7	GND
PIN8	No connection

Conn J4 (Digital0_7)	Signal
PIN1	D0_RX (Arduino ---> M95 GSM Shield) default
PIN2	D1_TX (M95 GSM Shield ---> Arduino) default
PIN3	D2 (Alternative SW RX)

PIN4	D3 (Alternative SW TX)
PIN5	PWRKEY+
PIN6	EMERG+
PIN7	No connection
PIN8	D7 (Could be used to switch VREG input ON/OFF)

**Component placement and board overview:**

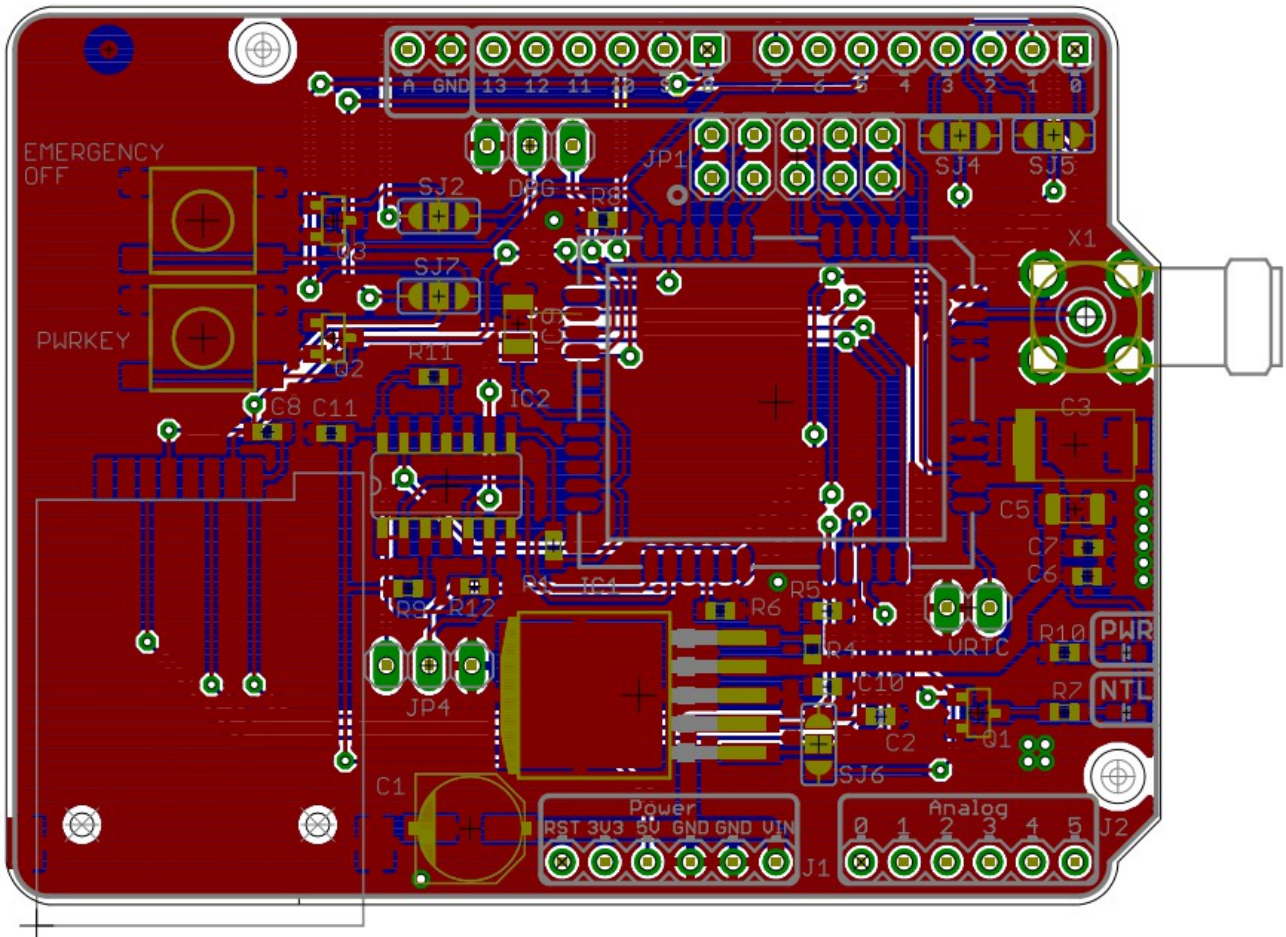

# QUECTEL M95 ARDUINO SHIELD 2015

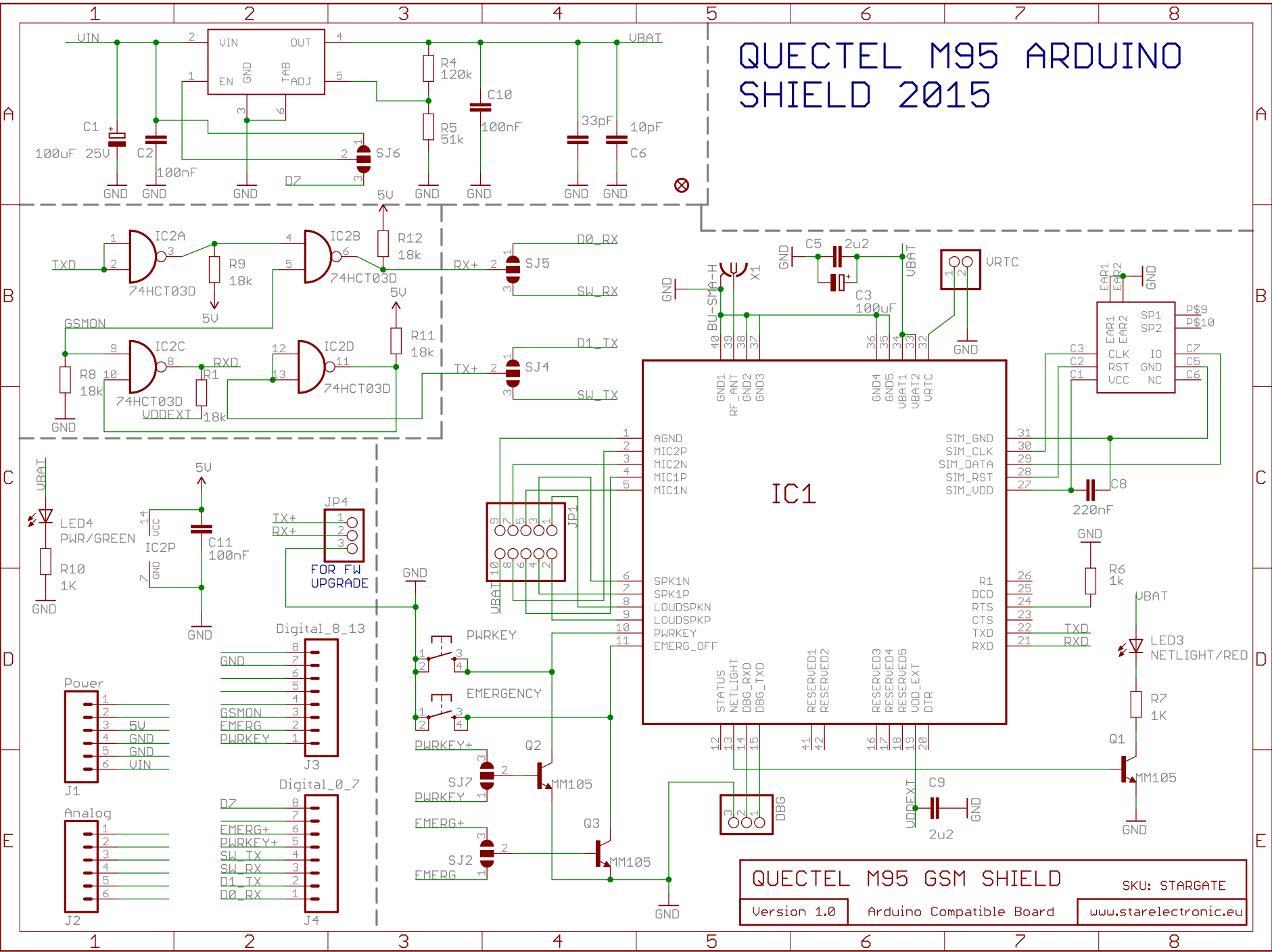

**QUECTEL M95 GSM SHIELD** SKU: STARGATE  
 Version 1.0 Arduino Compatible Board www.starelectronic.eu



reference

**2J010**

frequency

**AMPS / GSM900 / GSM1800  
UMTS2100 / Bluetooth2400**

vswr

**<2:1**

impedance

**50 Ohms**

polarisation

**vertical**

gain

**2.2 dBi**

connector

**SMA Male**

working temperature

**-40°C to +85°C**

size

**53mm x 9.65mm**

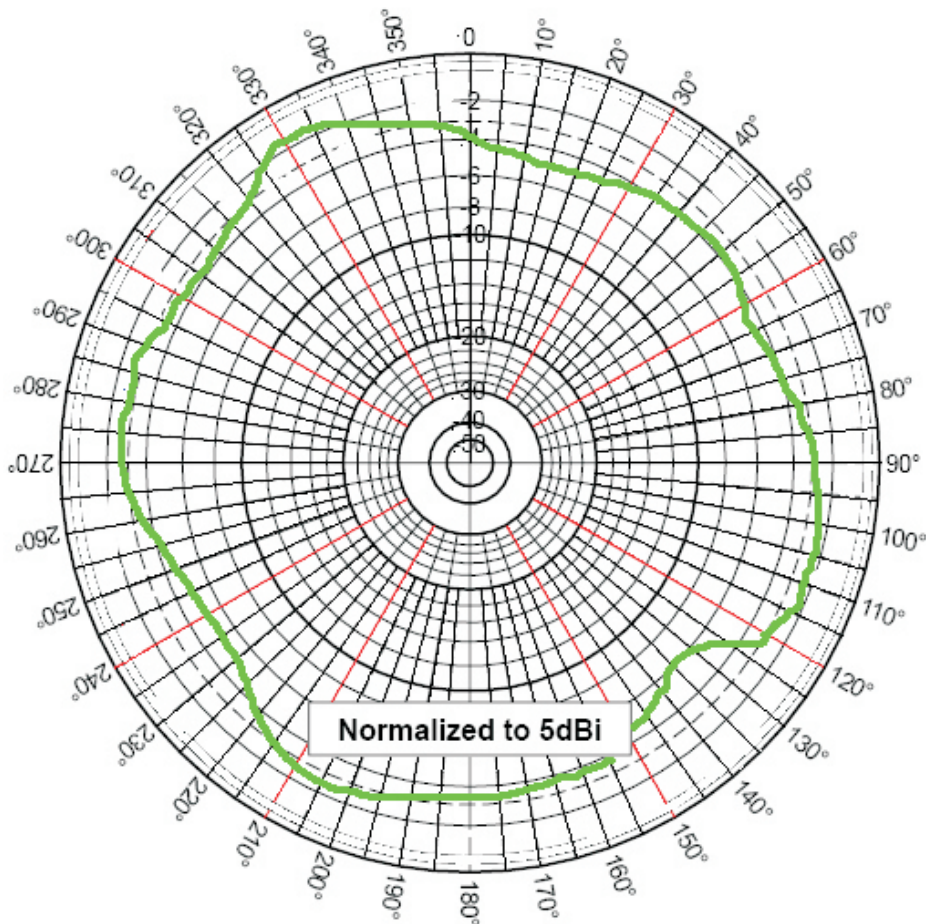
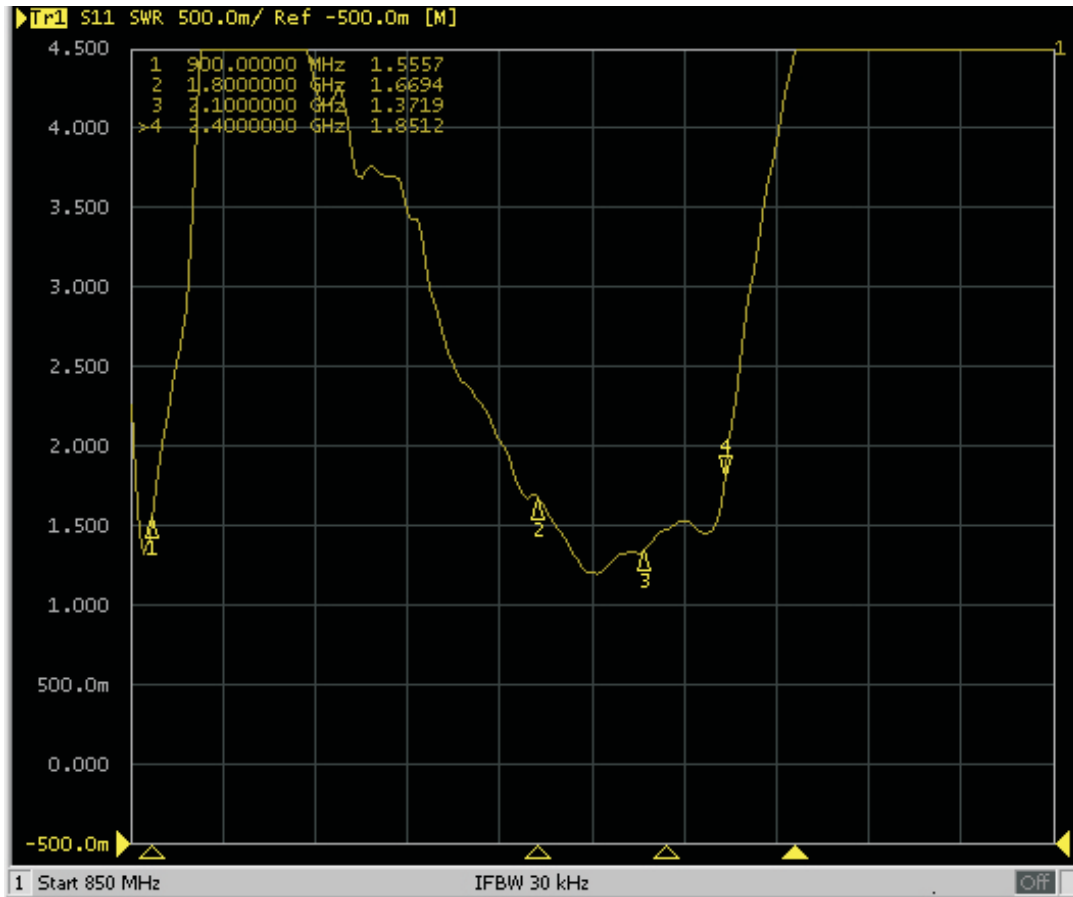

Azimuthal Pattern (X, Y or E-Plane)

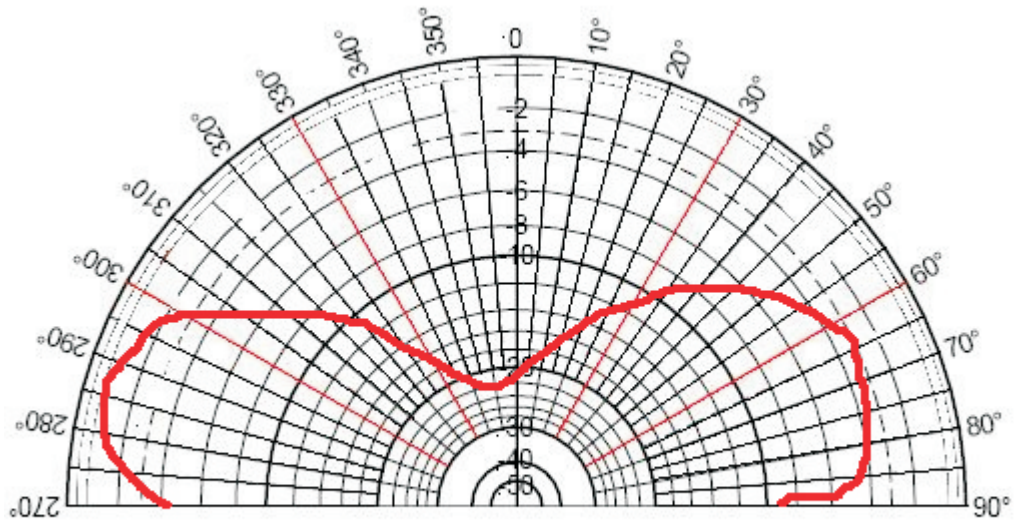

Elevation Pattern (Z, Y or H-Plane)