

Order code	Manufacturer code	Description
78-0743	\$F12011F-0202-20R-M-011	DPDT MOMENTARY ACTION FOOT SWITCH RC

	Page 1 of 9
The enclosed information is believed to be correct, Information may change without notice due to product improvement. Users should ensure that the product is suitable for their use. E. & O. E.	Revision A 20/02/2007

CUSTOMER'S NAME

RAPID ELECTRONICS

ALPHA REFERENCE NO.

SP09020024

SPECIFICATION

PART NO.	ALPHA MODEL NAME
1.	SF12011F-0202-20R-M-011
	78-0743

MODEL NAME
MODEL NO.

APPROVAL

PREPARED BY	REVIEWED BY	APPROVED BY
 98. 2. 3 鳳妮	 98. 2. 3 任維	 2005. 2. 03 茂松



台灣艾華電子工業股份有限公司

桃園市中正路1221~1223號9樓

TAIWAN ALPHA ELECTRONIC CO., LTD.

9F, NO. 1221, Chung Cheng Rd., Taoyuan, Taiwan

TEL:886-3-3577799 FAX:886-3-3577700

E-mail:sales@taiwanalpha.com.tw

URL:http://www.taiwanalpha.com

FOOT SWITCH

MODEL

SF12011F-0202-20R-M-011

SPECIFICATIONS

Rating	AC125V 6A AC250V 3A DC30V 4A
Contact Resistance	50mΩ Max. Silver contacts
Insulation Resistance	DC500V-100 MΩMin.
Withstand Voltage	AC1000V-1 Minute
Operating Force	2.8±0.8Kgf
Life Cycles	20000 Cycles
Sizes (m.m)	As Following Drawing

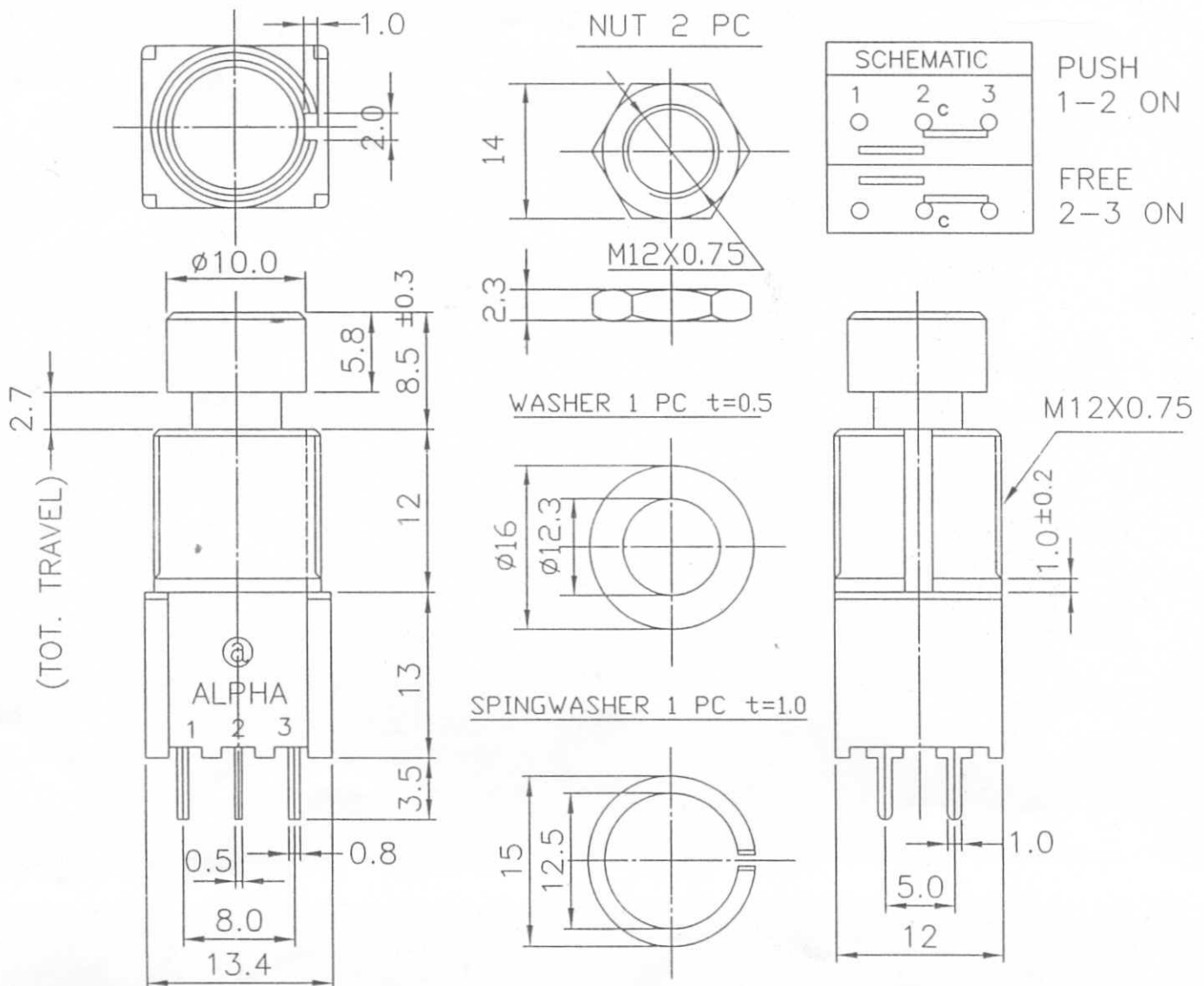

NOTE: 1. TOLERANCES UNLESS OTHERWISE SPECIFIED: ±0.3mm
2. FUNCTION: MOMENTARY

Date	2005.03.03	DWN	張月琴 95.8.16	CHKD	何理志 95.8.16	APP'D	楊子鑫 95-8-17
------	------------	-----	----------------	------	----------------	-------	----------------

TAIWAN ALPHA ELECTRONIC CO., LTD.

	Specification Rotary switch SF12011F-0202-M SF12014F-0202-M SF12020F-0202-M	DOC. No: Rev. A
		Date: 2/13/2006
		Author: 何建志
		Approved: 王茂松

CONTENTS 內容

Section 項目	Description 敘述	Page 頁
1.0	Scope 目的	2
2.0	Applicable Documents and Specifications 可應用的文件和規格	2
3.0	Criteria 範圍	2
4.0	Mechanical Performance Specifications 機械性能規格	3-4
5.0	Electrical Performance Specifications 電氣性能規格	4
6.0	Endurance Performance Specifications 耐久性規格	5

	Specification	DOC. No: Rev. A
	Rotary switch	Date: 2/13/2006
	SF12011F-0202-M	Author: 何建志
	SF12014F-0202-M SF12020F-0202-M	Approved: 王茂松

1.0 SCOPE 目的

Application : The specification is applicable signal selector used in electronic equipment.

此規格主要適用於一般電子機器之小電流信號切換按壓式開關。

2.0 APPLICABLE DOCUMENTS AND SPECIFICATIONS 可應用的文件和規格

See product drawings and any other sections of this specification for the relevant documents.

In case where the product specification differs from the product drawings, the product drawings take precedence.

在看產品圖及此規格的相關參考文件的任何部分，若發現產品規格與產品圖不同，產品圖應優先。

3.0 Criteria 範圍

Unless otherwise specified, the standard range of atmospheric conditions for making measurements and conducting tests is as follows ;

排除使用詳細說明以外的方法。製造、測量及試驗在大氣環境標準範圍如下：

3.1 Ambient temperature	: 5°C ~ 35°C
周圍溫度	: 5°C ~ 35°C
3.2 Relative humidity	: 45% ~ 85%
相對濕度	: 45% ~ 85%
3.3 Atmospheric pressure	: 86kPa ~ 106kPa
氣壓	: 86kPa ~ 106kPa
3.4 Operating temperature range	: -10°C ~ +70°C
操作溫度範圍	: -10°C ~ +70°C
3.5 Storage temperature range	: -40°C ~ +85°C
保存溫度範圍	: -40°C ~ +85°C

※If there is any doubt about the results, measurements shall be made within the following condition:

發生判定疑問或另有特別要求則以基準狀態：Ambient temperature 周圍溫度 20°C ± 2°C，

Relative humidity 相對濕度 60% to 70%, Air pressure 氣壓 86kPa to 106kPa

	Specification	DOC. No: Rev. A
	Rotary switch	Date: 2/13/2006
	SF12011F-0202-M	Author: 何建志
	SF12014F-0202-M	Approved: 王茂松
	SF12020F-0202-M	

4.0 MECHANICAL CHARACTERISTICS 機械性能規格

Item 項目	Test Condition 測試條件	Specification 規格
4.1 Operating force 動作力	N/A	2.8±0.8Kgf-cm Min
Item 項目	Test Condition 測試條件	Specification 規格
4.2 Terminal strength 端子強度	<p>A static force of 1000gf being applied in one direction on the tip of the terminal for 1 minute. One time per terminal.</p> <p>端子前端任一方向加 1000gf 之靜負荷一分鐘(每支端子限制一次)</p>	<p>The terminal may be deformed but shall not sustain any problem as deviation and breaking of terminal and breaking of insulation material, electrical performance of the above 4 shall be assured.</p> <p>不能有端子脫落,破壞及絕緣板破損之現象,端子可以彎曲且試驗後需通各電氣性能</p>
4.3 Actuator strength 操作強度	<p>A static force of 1kgf being applied in the direction of operation (stopper-side) for 1 minute.</p> <p>沿操作部之動作方向(止動側)加靜負荷 1kgf 1 分鐘</p> <p>A static force of 1kgf being applied in the direction of pulling for 1 minute (The test of self-lock must be unlock)</p> <p>在操作的拉出方向加 1kgf 的靜負荷 1 分鐘(單動者,於目標狀態解除後,再作試驗)</p>	<p>Shall be free from pronounced wobble , deformation , and mechanical abnormalities</p> <p>不能有顯著的鬆動,彎曲及機械異常現象發生</p>

	Specification	DOC. No: Rev. A
	Rotary switch	Date: 2/13/2006
	SF12011F-0202-M	Author: 何建志
	SF12014F-0202-M	Approved: 王茂松
	SF12020F-0202-M	

Item 項目	Test Condition 測試條件	Requirement 需求
4.4 Soldering 銲錫性	Regarding preheating, the entire flow Duration should not exceed 2 minutes, And soldering surface temperature (undersurface of PCB) shall be settled within 100°C. Temperature of solder 銲錫溫度 260±5°C Duration of dipping 浸泡時間 5~10 seconds	More then 90% of the dipped part shall be covered by solder 銲錫覆蓋 90%以上浸泡處
4.5 Soldering heat resistance 耐銲錫性	Flow soldering condition 錫爐溫度 to be performed in 10 seconds within 260±5°C Manual soldering condition 手焊溫度 to be performed in 3 seconds Max within 350±5°C	No abnormalities shall be observed in appearance and operation shall be assured. The section 5 below. 外觀無顯著變形及動作無異常且滿足第 5 項之電氣性能
4.6 Control wobble 軸晃動	Shall be measured by applying a static load of 100gf-cm to the tip of control unit. 適用於靜止狀態下, 於操作處頂端施壓 100gf-cm	Less than 1 mm 小於 1 mm

5.0 Electrical Performance Specifications 電氣性能規格

5.1 Contact resistance 接觸阻抗	電壓下降法測定 Shall be measured at 1KHz±200KHz (Max 50mA ,Max 20mV) or 5VDC, 1A by a voltage drop method	50mΩ Max
	After life test 壽命測試後	80mΩ Max

	Specification Rotary switch SF12011F-0202-M SF12014F-0202-M SF12020F-0202-M	DOC. No: Rev. A
		Date: 2/13/2006
		Author: 何建志
		Approved: 王茂松

5.2 Insulation resistance 絕緣阻抗	To be measured with an insulation device of 500V DC between all the terminals and between the terminals frame for 1 minute ± 5 seconds 以 500V DC 之電壓加於端子相互間及端子與外殼間 1 分±5 秒測試之	More than 100MΩ 超過 100 MΩ
5.3 Voltage proof 耐電壓	1000V AC (50~60Hz) being applied between all the adjacent terminals and between all the terminals and between the terminals and the frame for 1 minute ±5 sec 以 1000V AC 之電壓加於端子相互間及端子與外殼間 1 分±5 秒測試之	No breaking insulation 不可有絕緣破壞現象
5.4 Rating 額定電壓電流	N/A	125VAC 6A, AC250VAC 3A, 30VDC 4A

6.0 ENDURANCE PERFORMANCE SPECIFICATIONS 耐久規格

Item 項目	Test Condition 測試條件	Specification 規格
6.1 Operating life (without load) 無負載壽命	20,000cycle operations at a rate of 15/20 cycle/minute without load 在無負載下連續動作 20,000 次 (15~20 次/分)	Contact resistance :max 80mΩ 接觸阻抗:80mΩ 以下 Operating force : 2.8±0.8kgf 動作力 : 2.8±0.8kgf
6.2 Operating life (with load) 負載壽命	20,000cycle operations at rate of 15/20 cycle/minute with a load of 30V DC 4A DC30V 4A 阻抗負載下連續動作 20,000 次(15~20 次/分)	Contact resistance :max 150mΩ 接觸阻抗:150mΩ 以下 Operating force : 2.8±0.8kgf 動作力 : 2.8±0.8kgf

可變電阻無鉛焊錫共通規格書

Common Specification of Lead-Free Soldering for Potentiometers

以下焊錫條件以可變電阻置於單層 1.6mm 厚度之印刷電路板上測試為基準。

The specification below is based on testing results of 1.6mm thickness single layer printed circuit board.

1. 手工焊錫條件：

For Manual Soldering：

1-1 操作溫度最高 350°C，操作時間 3 秒以內。

To be performed within 3 seconds at 350°C or below.

2. 自動或半自動機台焊錫條件：

For Automated or Semi-Automated Soldering Equipments:

2-1 使用發泡式且比重 0.82 以上的助焊劑，發泡高度以印刷電路板厚度一半為標準，且助焊劑不能流入可變電阻基板表面及印刷電路板表面。

Flux of 0.82 specific gravity, applied by foam fluxer, shall be used. Foam head shall be limited to the height which is half thickness of printed circuit board to be soldered. No flux should be allowed to run up onto resistive element board of potentiometer and the surface of printed circuit board.

2-2 預熱時間不超過兩分鐘，焊錫界面 (即印刷電路板底) 最高預熱溫度不超過 100°C。

Regarding preheating, the entire flow duration should not exceed 2 minutes, and soldering surface temperature (undersurface of PCB) shall be settled within 100°C.

2-3 焊錫過程機台設定溫度在 260°C 以下、4 秒以內。

Solder Dipping is to be performed within 4 seconds at 260°C or below.

3. 若可變電阻為帶有檔位，請將主軸或滑柄先調整至其中一個檔位或中心檔位上才可以進行焊錫作業。

For potentiometer with centre detent or multiple detents, its shaft or lever should be settled in relevant detent position prior to soldering process.

4. 手工焊錫、自動或半自動機台焊錫不得超過一回。

Regardless of soldering facility and method, solder dipping or solder smearing must not be carried out more than 1 time.

註：本項焊錫溫度條件不適用於回流焊接作業設備。

Remarks : This specification is not recommended for and applicable in reflow soldering.