Ultra-Fast Fully Insulated FASTON* Receptacle Terminals

1. SCOPE

1.1. Content

This specification covers the performance requirements for Ultra-Fast fully insulated FASTON* receptacle terminals. These terminals consist of a FASTON receptacle body enclosed in a fully insulated housing. They mate with FASTON tabs on devices used in home entertainment centers, business machines, copying equipment, computer peripherals, appliances and other commercial equipment

1.2. Qualification

When tests are performed on the subject product line, procedures specified in Figure 1 shall be used. All inspections shall be performed using the applicable inspection plan and product drawing.

2. APPLICABLE DOCUMENTS

The following documents form a part of this specification to the extent specified herein. Unless otherwise specified, the latest edition of the document applies. In the event of conflict between the requirements of this specification and the product drawing, the product drawing shall take precedence. In the event of conflict between the requirements of this specification and the referenced documents, this specification shall take precedence.

2.1. TE Connectivity (TE) Documents

- 109-1: General Requirements for Test Specifications
- 109 Series: Test Specifications as indicated in Figure 1
- 114-2123: Application Specification

2.2. Commercial Standards

- CSA C22.2 No 153: Quick-Connect Terminals
- DIN VDE 0627: Connectors and Plug-And-Socket Devices
- UL 310: Quick-Connect Terminals, Standard for

3. REQUIREMENTS

3.1. Design and Construction

Product shall be of the design, construction and physical dimensions specified on the applicable product drawing.

3.2. Materials

- Receptacle body: Brass or phosphor bronze, tin plated
- Housing: Nylon type 6/6, UL 94V-2
- Tabs (for test purposes): Brass, temper 2, CDA alloy
- Wire (for test purposes): Complies with UL 310 Paragraph 7, 600 Volt rating

3.3. Ratings

- Voltage: 600 volts AC maximum
- Operating Temperature: 105°C maximum

3.4. Performance and Test Description

Product is designed to meet the electrical, mechanical and environmental performance requirements specified in Figure 1.

3.5. Test Requirements and Procedures Summary

Test Description	Requirement	Procedure
Examination of Product.	Meets requirements of product drawing and Application Spec 114-2123.	TE Spec 109-1. Visual, dimensional and functional per applicable inspection plan.
ELECTRICAL		
Dielectric Withstanding Voltage, Test Condition A.	No breakdown or flashover when 3400 volts AC are applied for 1 minute.	UL 310, 600 Volt Rating. Test wired terminals in Number 12 lead shot.
Dielectric Withstanding Voltage, Test Condition C.	No breakdown or flashover at rear of terminal when 3000 volts AC are applied for 1 minute.	UL 310, 600 Volt Rating. Test on flat metal plate. See Figure 4.
Dielectric Withstanding Voltage, Receptacle, Tab Entry Position.	Terminal Size Applied Voltage (volts AC)	TE Spec 109-29-1. Test wired terminals on a flat metal plate. See Figure 5.
	250 1000 187 1000 110 600	
Heating (Temperature Rise).	Wire Size (AWG) Current (amperes) .110 Others	UL 310. Stabilize at specified current and measure temperature rise.
	26 1 1	
	24 2 2	
	22 2 3	
	20 3 4	
	18 4 7	
	16 5 10	
	14 8 15	
12 – 20		
10 – 24		
		20°C maximum temperature rise.

Figure 1 (continued)

Test Description	Requirement	Procedure	
Heat Cycling (Current Cycling).	Wire Size (AWG)	Current (amperes) Others	
	26	2	
	24	4	
	22	4	
	20	6	
	18	8	
	16	10	
	14	15	
	12	–	
	10	–	
65°C maximum temperature rise. Δ Temperature rise between 24 and 500 cycles shall not exceed 15°C on any conductor.		UL 310. Subject samples to 500 current cycles of 45 minutes ON and 15 minutes OFF.	
MECHANICAL			
Pull Out (Crimp Tensile).	Wire Size (AWG)	Tensile (Lbs minimum)	
	26	4	
	24	6	
	22	10	
	20	16	
	Above values are less than maximum withdrawal force. See Figure 2.		
	18	20	
	16	30	
	14	60	
	12	70	
10	80		
Secureness of Insulation (Unassembled).	No separation of the insulation from the terminal body.	UL 310. Subject unwired terminals to a 3 pound pull between the insulation and terminal for 1 minute.	
Secureness of Insulation (Assembled).	No separation of the insulation from the terminal body.	UL 310. Subject wired terminals to a 6 pound pull between the insulation and terminal for 1 minute.	
Engagement-Disengagement (Engaging-Separating).	See Figure 2.	UL 310. Engage and disengage terminals and tabs 6 times.	
ENVIRONMENTAL			
Heat Age, 136°C.	Meet Dielectric Withstanding Voltage, Test Condition A; and Secureness of Insulation (assembled and unassembled).	UL 310. Subject terminals to 136°C for 7 days.	
Heat Age/Humidity.	Meet Dielectric Withstanding Voltage, Test Condition A.	UL 310. Subject unwired terminals to 100°C for 7 days followed by 85% RH at 30°C for 24 hours.	

Figure 1 (end)

Tab Size (Plain Brass)	Terminal Plating	Force (pounds)					
		First Insertion	First Withdrawal			Sixth Withdrawal	
		Individual (max)	Individual (max)	Average (min)	Individual (min)	Average (min)	Individual (min)
.250	Tin	17	17	5	3	4	3
.205/.187		15	20	5	3	3	2
.110		12	14	3	2	2	1

Figure 2
Engagement and Disengagement Forces

3.6. Terminal Tests and Sequences

Test or Examination	Test Group (a)											
	1	2	3	4	5	6	7	8	9	10	11	12
	Test Sequence (b)											
Examination of Product	1	1	1	1	1	1	1	1	1	1	1	1
Dielectric Withstanding Voltage, Test Condition A		2	3	3(c)								
Dielectric Withstanding Voltage, Test Condition C					2							
Dielectric Withstanding Voltage, Receptacle, Tab Entry Position						2						
Heating (Temperature Rise)	2											
Heat Cycling (Current Cycling)	3											
Pull Out (Crimp Tensile)		3										
Secureness of Insulation (Unassembled)							2		3			
Secureness of Insulation (Assembled)								2		3	3(c)	
Engagement-Disengagement (Engaging-Separating)												2
Heat Age, 136°C			2							2		
Heat Age/Humidity				2					2		2	

NOTE

- (a) See paragraph 4.1.A.
- (b) Numbers indicate sequence in which tests are performed.
- (c) Uncrimped terminals and wires in test groups 4 and 11 shall be conditioned in the environments indicated. After conditioning, each sample is crimped to the appropriate wire and the electrical or mechanical test is performed.

Figure 3

4. QUALITY ASSURANCE PROVISIONS

4.1. Qualification Testing

A. Sample Selection

Terminals and tabs shall be prepared in accordance with applicable Instruction Sheets and shall be selected at random from current production. Test groups 1, 2, 3 and 4 shall each consist of 20 samples of each wire size and terminal type per group. Test groups 5, 6, 7, 8, 9, 10, 11 and 12 shall each consist of 20 samples of each terminal type per group. All samples to be terminated shall be crimped to appropriate tin plated test conductors.

B. Test Sequence

Qualification inspection shall be verified by testing samples as specified in Figure 3.

C. Acceptance

1. Requirements put on the test samples, as indicated in the Requirements portion of Figure 1, exist as either the upper or lower statistical tolerance limit (95% confidence, 98% reliability). All samples tested in accordance with this specification shall meet the stated tolerance limit.
2. Failures attributed to equipment, test setup or operator deficiencies shall not disqualify the product. When product failure occurs, corrective action shall be taken and samples resubmitted for qualification.

4.2. Quality Conformance Inspection

The applicable inspection plan will specify the sampling acceptable quality level to be used. Dimensional and functional requirements shall be in accordance with the applicable product drawing and this specification.

4.3. Certification

This product has been recognized under the Component Recognition Program of Underwriters Laboratories Inc., Electrical File Number E-66717 and certified by Canadian Standards Association File Numbers LR-7189. Also, VDE Testing and Certification Institute, Reference No. 4751_1431_1047.

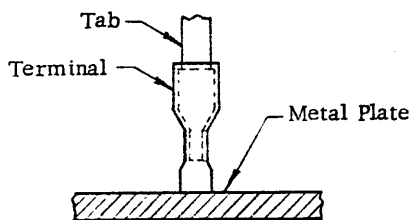

Figure 4
Metal Plate Test Fixture

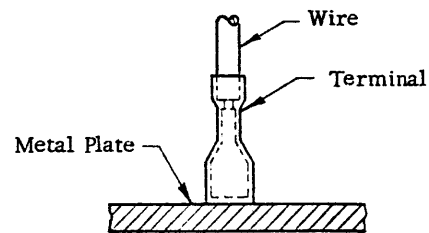

Figure 5
Tab, Receptacle Entry Position

4

3

2

1

THIS DRAWING IS UNPUBLISHED. RELEASED FOR PUBLICATION
 © COPYRIGHT - By - ALL RIGHTS RESERVED.

LOC	DIST	REVISIONS			
P	LTR	DESCRIPTION	DATE	DWN	APVD
AF	50	M	REVISED PER ECR-13-004343	30JUL13	KH KR

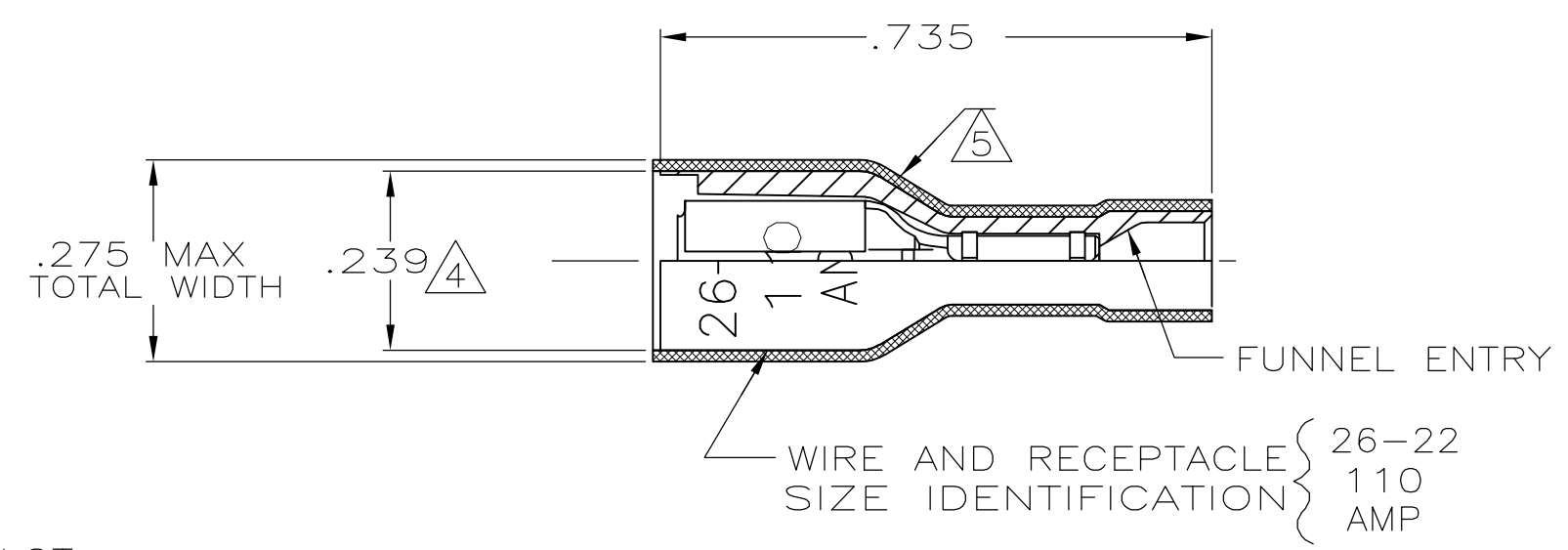

- 1 MATES WITH .020±.001x.110 OR .125 TABS.
- 2 WIRE STRIP LENGTH .281
- 3 INSULATION SIZE .100 MAX DIA
- △4 DIMENSION DOES NOT INCLUDE TRIM BURR
- △5 .015 MAX CARRIER TRIM BURR PER SIDE IS ALLOWABLE IN THE SHADED AREA

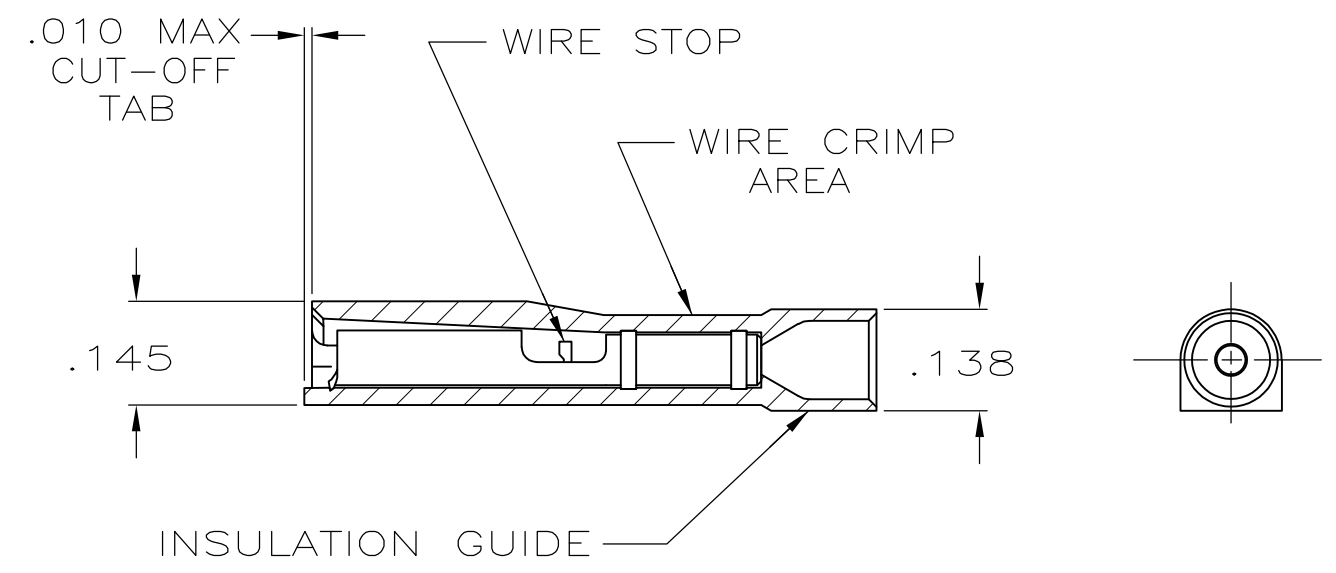
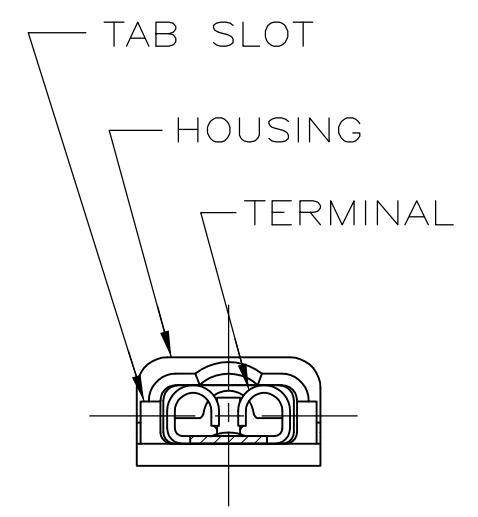

HOUSING: NYLON, COLOR-VIOLET TINT RECEPTACLE: BRASS, TIN	7-520366-2
MATERIAL & FINISH	PART NO

THIS DRAWING IS A CONTROLLED DOCUMENT.		DWN P FORTNEY 11/14/88	TE Connectivity RECEPTACLE ASSY, ULTRA-FAST, LOOSE PIECE, .110/.125 SERIES, 26-22 AWG		
DIMENSIONS: INCHES		CHK MS FEHER 11/15/88			
TOLERANCES UNLESS OTHERWISE SPECIFIED:		APVD K RANDOLPH 11/15/88			
0 PLC ± - 1 PLC ± - 2 PLC ± - 3 PLC ± .015 4 PLC ± - ANGLES ± -		NAME			
MATERIAL SEE TABLE		FINISH SEE TABLE	PRODUCT SPEC 108-2043	APPLICATION SPEC 114-2123	RESTRICTED TO
		WEIGHT -	SIZE A3	CAGE CODE 00779	DRAWING NO C-520366
CUSTOMER DRAWING			SCALE 4:1	SHEET 1 OF 1	REV M

THIS DRAWING IS UNPUBLISHED. RELEASED FOR PUBLICATION
 © COPYRIGHT - By - ALL RIGHTS RESERVED.

LOC	DIST	REVISIONS			
P	LTR	DESCRIPTION	DATE	DWN	APVD
AF	50	T	REVISED PER ECR-13-004343	30JUL13	KH KR

- 1 FITS 0.81±0.025 X 6.35 [.032±.001 X .250] TAB
- 2 WIRE SIZE: 0.3-0.9mm² [22-18 AWG], STRANDED ONLY. STRIP LENGTH 7.94 [.312]
- 3 INSULATION SIZE: 4.19 [.165] MAX DIA.
- 4 SUPPLIED AS LOOSE PIECE.

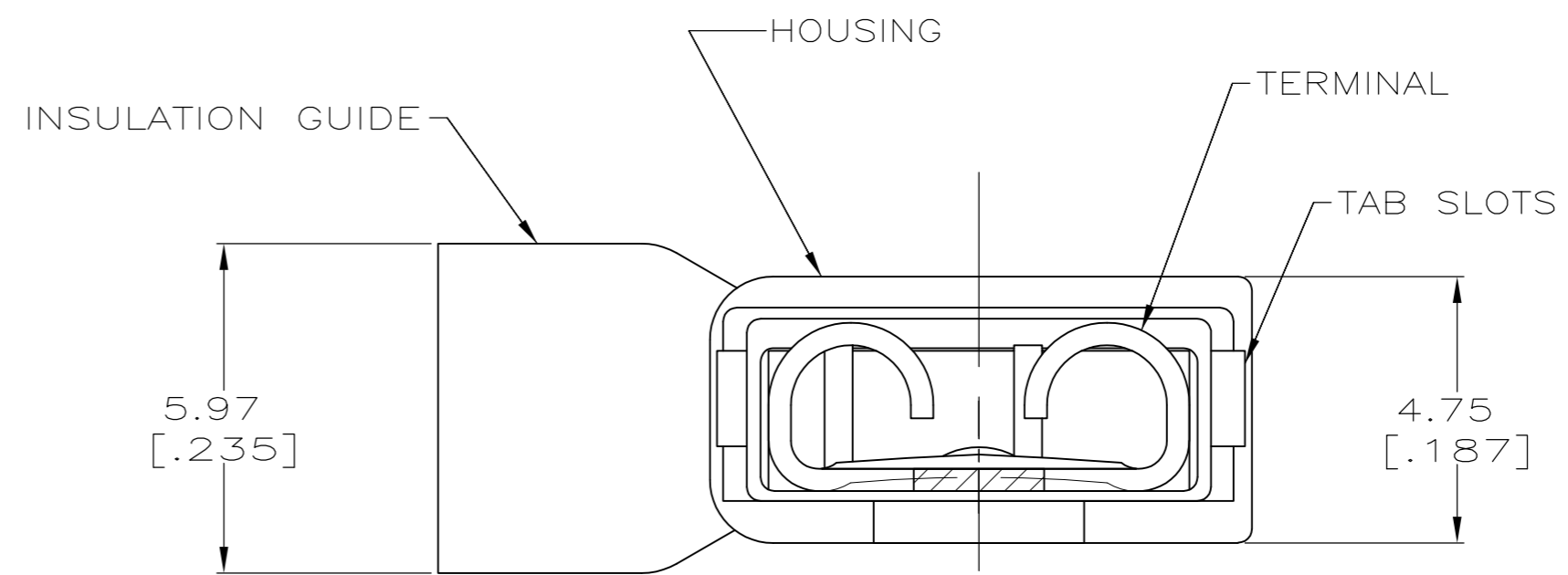
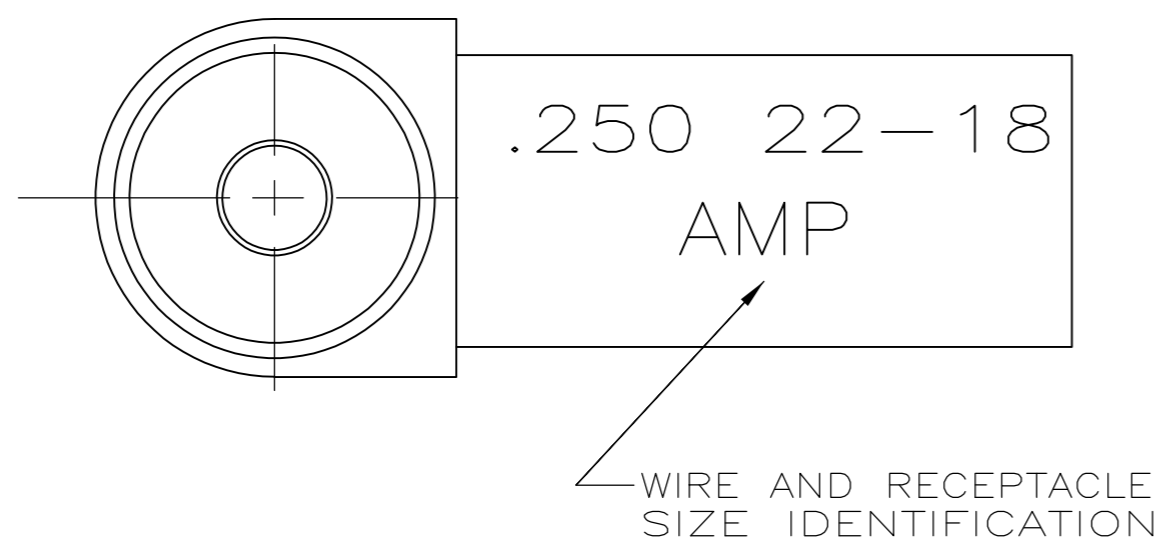
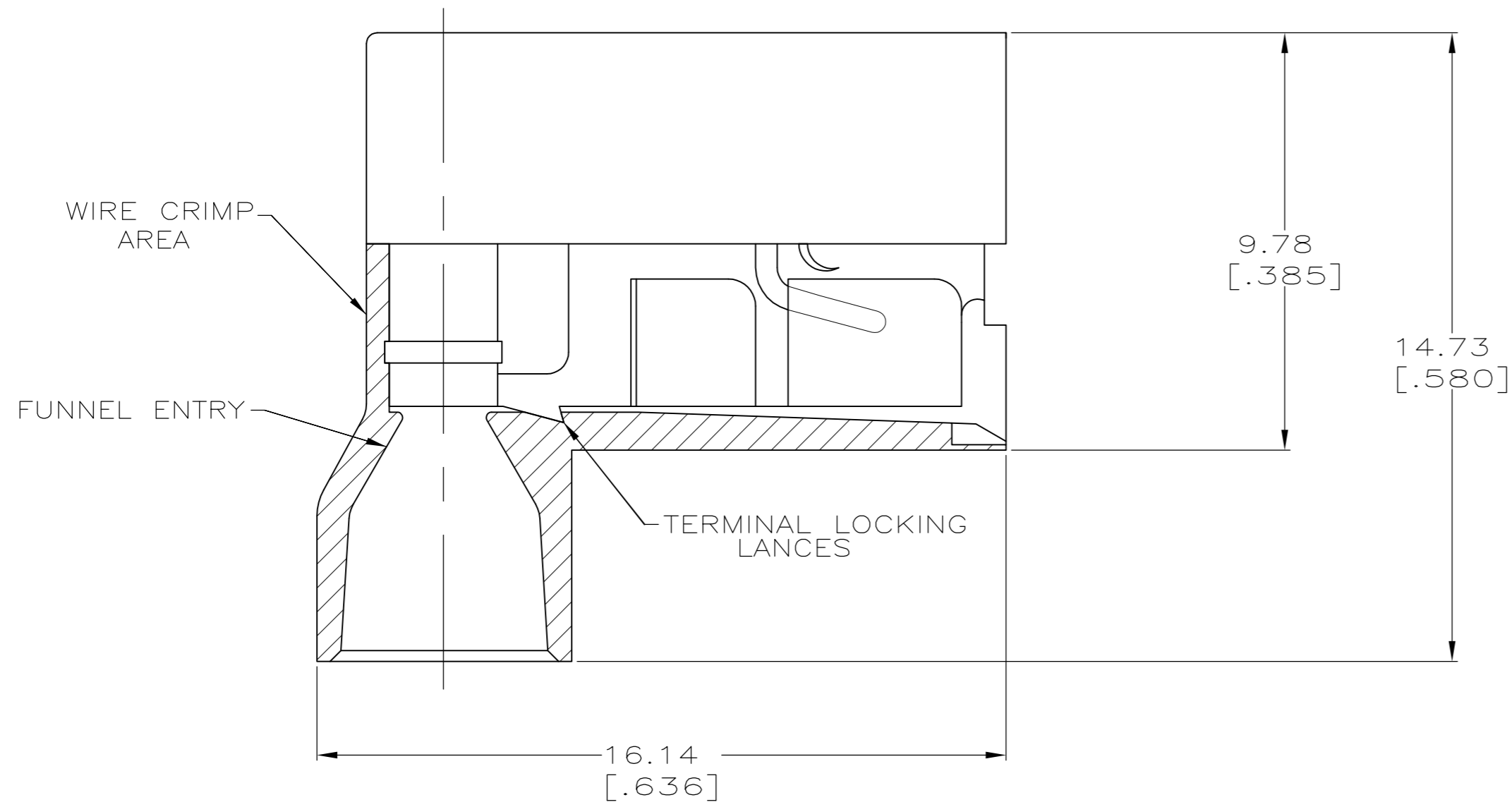

TYPE 6/6 NYLON	RED TRANSLUCENT	BRASS	TIN	2-520129-2
MATERIAL	COLOR	MATERIAL	FINISH	PART NO
HOUSING		TERMINAL		

THIS DRAWING IS A CONTROLLED DOCUMENT.		DWN P FORTNEY 10/19/89	 TE Connectivity		
DIMENSIONS: mm [INCHES]		CHK JR RUTH 10/19/89			
TOLERANCES UNLESS OTHERWISE SPECIFIED:		APVD D BRATINA 10/19/89			
0 PLC ± - 1 PLC ± - 2 PLC ± - 3 PLC ± 0.38 [.015] 4 PLC ± - ANGLES ± -		PRODUCT SPEC 108-2043	NAME RECEPTACLE ASSEMBLY, ULTRA-FAST FLAG, 6.35 [.250] SERIES		
MATERIAL SEE TABLE		APPLICATION SPEC 114-2123	SIZE A2	CAGE CODE 00779	DRAWING NO C=520129
FINISH SEE TABLE		WEIGHT -	RESTRICTED TO -		
CUSTOMER DRAWING			SCALE 8:1	SHEET 1 OF 1	REV T