

<b>Order code</b>	<b>Manufacturer code</b>	<b>Description</b>
82-3064	n/a	LD1117V30 3V 0.8A REG
82-3066	n/a	LD1117V33 3.3V 0.8A REG

	Page 1 of 15
The enclosed information is believed to be correct, Information may change 'without notice' due to product improvement. Users should ensure that the product is suitable for their use. E. & O. E.	Revision A 04/07/2003



# LD1117 SERIES

## LOW DROP FIXED AND ADJUSTABLE POSITIVE VOLTAGE REGULATORS

- LOW DROPOUT VOLTAGE (1V TYP)
- 2.85V DEVICE PERFORMANCES ARE SUITABLE FOR SCSI-2 ACTIVE TERMINATION
- OUTPUT CURRENT UP TO 800mA
- FIXED OUTPUT VOLTAGE OF: 1.8V, 2.5V, 2.85V, 3.0V, 3.3V, 5.0V
- ADJUSTABLE VERSION AVAILABILITY ( $V_{ref}=1.25V$ )
- INTERNAL CURRENT AND THERMAL LIMIT
- AVAILABLE IN  $\pm 1\%$  (AT 25°C) AND 2% IN FULL TEMPERATURE RANGE
- SUPPLY VOLTAGE REJECTION : 75 dB (TYP)
- TEMPERATURE RANGE : 0°C TO 125°C

### DESCRIPTION

The LD1117 is a LOW DROP Voltage Regulator able to provide up to 800mA of Output Current, available even in adjustable version ( $V_{ref}=1.25V$ ). Concerning fixed versions, are offered the following Output Voltages: 2.5V, 2.85V, 3.0V, 3.3V and 5.0V. The 2.85V type is ideal for SCSI-2 lines active termination. The device is supplied in: SOT-223, DPAK, SO-8 and TO-220. The SOT-223 and DPAK surface mount packages optimize the thermal characteristics even offering a relevant space saving effect. High efficiency is assured by NPN

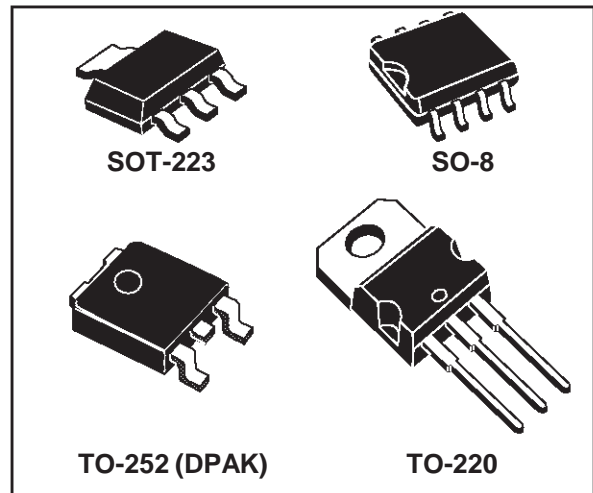

pass transistor. In fact in this case, unlike than PNP one, the Quiescent Current flows mostly into the load. Only a very common 10 $\mu$ F minimum capacitor is needed for stability. On chip trimming allows the regulator to reach a very tight output voltage tolerance, within  $\pm 1\%$  at 25 °C. The ADJUSTABLE LD1117 is pin to pin compatible with the other standard Adjustable voltage regulators maintaining the better performances in terms of Drop and Tolerance.

### BLOCK DIAGRAM

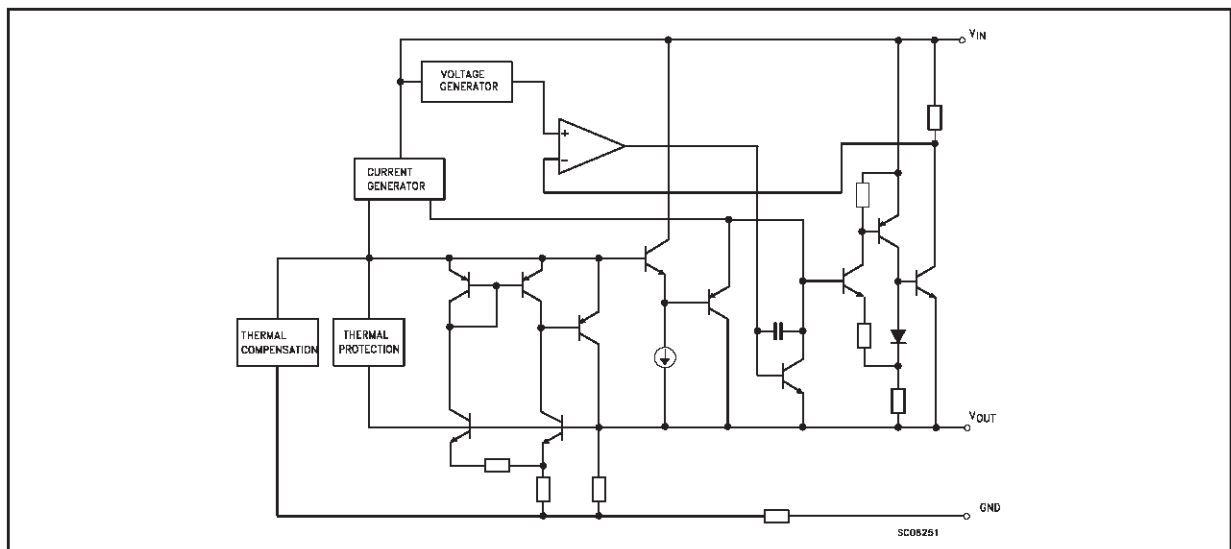

## LD1117 SERIES

### ABSOLUTE MAXIMUM RATINGS

Symbol	Parameter	Value	Unit
$V_{IN}$	DC Input Voltage	15	V
$P_{tot}$	Power Dissipation	12	W
$T_{stg}$	Storage Temperature Range	-40 to 150	°C
$T_{op}$	Operating Junction Temperature Range	0 to 125	°C

Absolute Maximum Ratings are those value beyond which damage to the device may occur. Functional operation under these condition is not implied. Over the above suggested Max Power Dissipation a Short Circuit could definitively damage the device.

### THERMAL DATA

Symbol	Parameter	SOT-223	SO-8	DPAK	TO-220	Unit
$R_{thj-case}$	Thermal Resistance Junction-case	15	20	8	3	°C/W
$R_{thj-amb}$	Thermal Resistance Junction-ambient				50	°C/W

### APPLICATION CIRCUIT

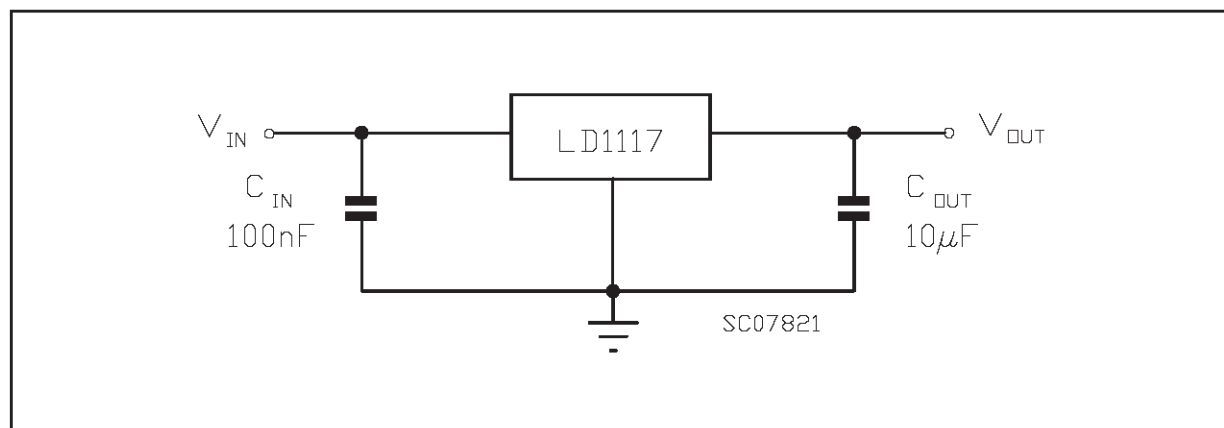

CONNECTION DIAGRAM AND ORDERING NUMBERS (top view)

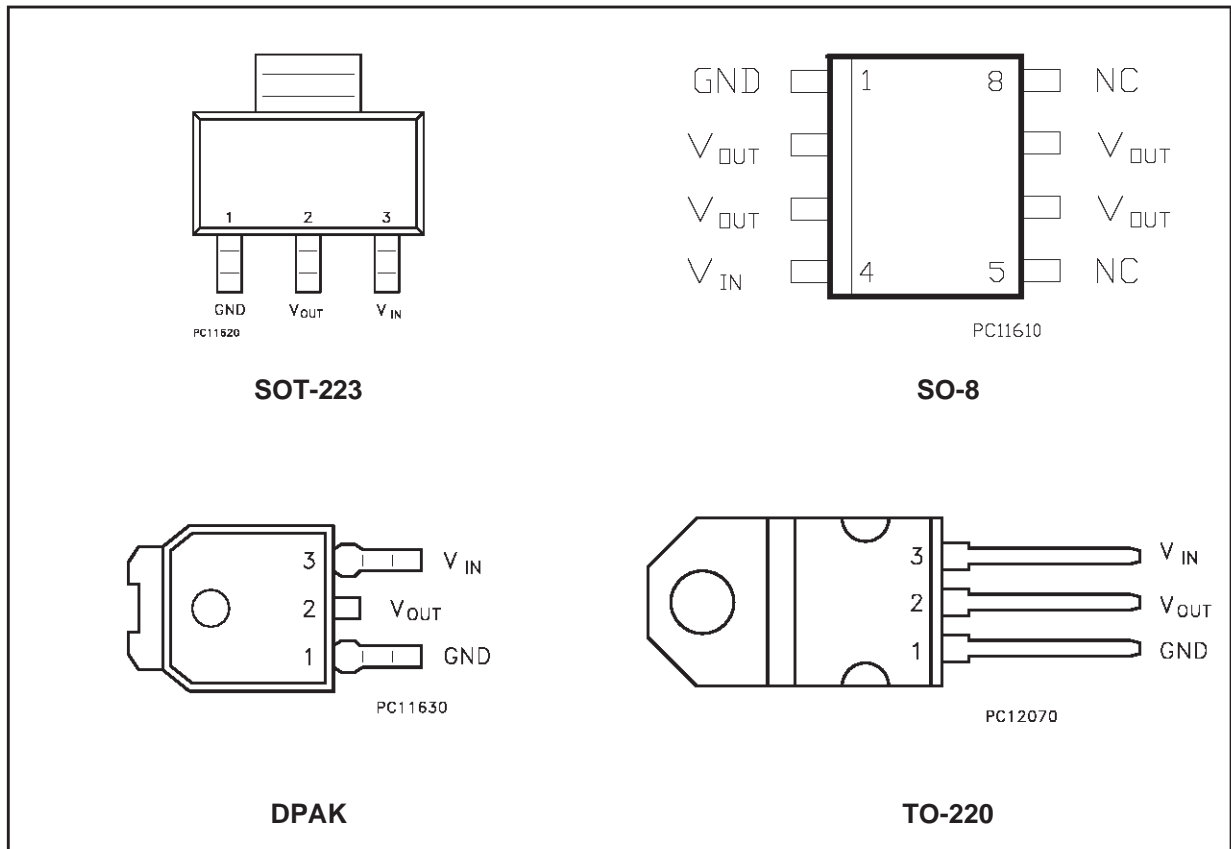

SOT-223	SO-8	DPAK	TO-220	Output Voltage
LD1117S18	LD1117D18	LD1117DT18	LD1117V18	1.8V
LD1117S18C	LD1117D18C	LD1117DT18C	LD1117V18C	1.8V
LD1117S25	LD1117D25	LD1117DT25	LD1117V25	2.5V
LD1117S25C	LD1117D25C	LD1117DT25C	LD1117V25C	2.5V
LD1117S28	LD1117D28	LD1117DT28	LD1117V28	2.85V
LD1117S30	LD1117D30	LD1117DT30	LD1117V30	3V
LD1117S30C	LD1117D30C	LD1117DT30C	LD1117V30C	3V
LD1117S33	LD1117D33	LD1117DT33	LD1117V33	3.3V
LD1117S33C	LD1117D33C	LD1117DT33C	LD1117V33C	3.3V
LD1117S50	LD1117D50	LD1117DT50	LD1117V50	5V
LD1117S50C	LD1117D50C	LD1117DT50C	LD1117V50C	5V
LD1117S	LD1117D	LD1117DT	LD1117V	ADJUSTABLE FROM 1.25 TO 15V

## LD1117 SERIES

**ELECTRICAL CHARACTERISTICS FOR LD1117#18** (refer to the test circuits,  
 $T_j = 0$  to  $125\text{ }^\circ\text{C}$ ,  $C_o = 10\text{ }\mu\text{F}$  unless otherwise specified)

Symbol	Parameter	Test Conditions	Min.	Typ.	Max.	Unit
$V_o$	Output Voltage	$V_{in} = 3.8\text{ V}$ $I_o = 10\text{ mA}$ $T_j = 25\text{ }^\circ\text{C}$	1.78	1.8	1.82	V
$V_o$	Output Voltage	$I_o = 0$ to $800\text{ mA}$ $V_{in} = 3.3$ to $8\text{ V}$	1.76		1.84	V
$\Delta V_o$	Line Regulation	$V_{in} = 3.3$ to $8\text{ V}$ $I_o = 0\text{ mA}$		1	6	mV
$\Delta V_o$	Load Regulation	$V_{in} = 3.3\text{ V}$ $I_o = 0$ to $800\text{ mA}$		1	10	mV
$\Delta V_o$	Temperature Stability			0.5		%
$\Delta V_o$	Long Term Stability	1000 hrs $T_j = 125\text{ }^\circ\text{C}$		0.3		%
$V_{in}$	Operating Input Voltage	$I_o = 100\text{ mA}$			10	V
$I_d$	Quiescent Current	$V_{in} \leq 8\text{ V}$		5	10	mA
$I_o$	Output Current	$V_{in} = 6.8\text{ V}$ $T_j = 25\text{ }^\circ\text{C}$	800	950	1200	mA
eN	Output Noise Voltage	$B = 10\text{ Hz}$ to $10\text{ KHz}$ $T_j = 25\text{ }^\circ\text{C}$		100		$\mu\text{V}$
SVR	Supply Voltage Rejection	$I_o = 40\text{ mA}$ $f = 120\text{ Hz}$ $T_j = 25\text{ }^\circ\text{C}$ $V_{in} = 5.5\text{ V}$ $V_{ripple} = 1\text{ Vpp}$	60	75		dB
$V_d$	Dropout Voltage	$I_o = 100\text{ mA}$ $I_o = 500\text{ mA}$ $I_o = 800\text{ mA}$		1 1.05 1.10	1.1 1.15 1.2	V V V
	Thermal Regulation	$T_a = 25\text{ }^\circ\text{C}$ 30ms Pulse		0.01	0.1	%/W

**ELECTRICAL CHARACTERISTICS FOR LD1117#25** (refer to the test circuits,  
 $T_j = 0$  to  $125\text{ }^\circ\text{C}$ ,  $C_o = 10\text{ }\mu\text{F}$  unless otherwise specified)

Symbol	Parameter	Test Conditions	Min.	Typ.	Max.	Unit
$V_o$	Output Voltage	$V_{in} = 4.5\text{ V}$ $I_o = 10\text{ mA}$ $T_j = 25\text{ }^\circ\text{C}$	2.475	2.5	2.525	V
$V_o$	Output Voltage	$I_o = 0$ to $800\text{ mA}$ $V_{in} = 3.9$ to $10\text{ V}$	2.45		2.55	V
$\Delta V_o$	Line Regulation	$V_{in} = 3.9$ to $10\text{ V}$ $I_o = 0\text{ mA}$		1	6	mV
$\Delta V_o$	Load Regulation	$V_{in} = 3.9\text{ V}$ $I_o = 0$ to $800\text{ mA}$		1	10	mV
$\Delta V_o$	Temperature Stability			0.5		%
$\Delta V_o$	Long Term Stability	1000 hrs $T_j = 125\text{ }^\circ\text{C}$		0.3		%
$V_{in}$	Operating Input Voltage	$I_o = 100\text{ mA}$			15	V
$I_d$	Quiescent Current	$V_{in} \leq 10\text{ V}$		5	10	mA
$I_o$	Output Current	$V_{in} = 7.5\text{ V}$ $T_j = 25\text{ }^\circ\text{C}$	800	950	1200	mA
eN	Output Noise Voltage	$B = 10\text{ Hz}$ to $10\text{ KHz}$ $T_j = 25\text{ }^\circ\text{C}$		100		$\mu\text{V}$
SVR	Supply Voltage Rejection	$I_o = 40\text{ mA}$ $f = 120\text{ Hz}$ $T_j = 25\text{ }^\circ\text{C}$ $V_{in} = 5.5\text{ V}$ $V_{ripple} = 1\text{ Vpp}$	60	75		dB
$V_d$	Dropout Voltage	$I_o = 100\text{ mA}$ $I_o = 500\text{ mA}$ $I_o = 800\text{ mA}$		1 1.05 1.10	1.1 1.15 1.2	V V V
	Thermal Regulation	$T_a = 25\text{ }^\circ\text{C}$ 30ms Pulse		0.01	0.1	%/W

**ELECTRICAL CHARACTERISTICS FOR LD1117#28** (refer to the test circuits,  
 $T_j = 0$  to  $125\text{ }^\circ\text{C}$ ,  $C_o = 10\text{ }\mu\text{F}$  unless otherwise specified)

Symbol	Parameter	Test Conditions	Min.	Typ.	Max.	Unit
$V_o$	Output Voltage	$V_{in} = 4.85\text{ V}$ $I_o = 10\text{ mA}$ $T_j = 25\text{ }^\circ\text{C}$	2.82	2.85	2.88	V
$V_o$	Output Voltage	$I_o = 0$ to $800\text{ mA}$ $V_{in} = 4.25$ to $10\text{ V}$	2.79		2.91	V
$\Delta V_o$	Line Regulation	$V_{in} = 4.25$ to $10\text{ V}$ $I_o = 0\text{ mA}$		1	6	mV
$\Delta V_o$	Load Regulation	$V_{in} = 4.25\text{ V}$ $I_o = 0$ to $800\text{ mA}$		1	10	mV
$\Delta V_o$	Temperature Stability			0.5		%
$\Delta V_o$	Long Term Stability	1000 hrs $T_j = 125\text{ }^\circ\text{C}$		0.3		%
$V_{in}$	Operating Input Voltage	$I_o = 100\text{ mA}$			15	V
$I_d$	Quiescent Current	$V_{in} \leq 10\text{ V}$		5	10	mA
$I_o$	Output Current	$V_{in} = 7.85\text{ V}$ $T_j = 25\text{ }^\circ\text{C}$	800	950	1200	mA
eN	Output Noise Voltage	$B = 10\text{ Hz}$ to $10\text{ KHz}$ $T_j = 25\text{ }^\circ\text{C}$		100		$\mu\text{V}$
SVR	Supply Voltage Rejection	$I_o = 40\text{ mA}$ $f = 120\text{ Hz}$ $T_j = 25\text{ }^\circ\text{C}$ $V_{in} = 5.85\text{ V}$ $V_{ripple} = 1\text{ Vpp}$	60	75		dB
$V_d$	Dropout Voltage	$I_o = 100\text{ mA}$ $I_o = 500\text{ mA}$ $I_o = 800\text{ mA}$		1 1.05 1.1	1.1 1.15 1.2	V V V
	Thermal Regulation	$T_a = 25\text{ }^\circ\text{C}$ 30ms Pulse		0.01	0.1	%/W

**ELECTRICAL CHARACTERISTICS FOR LD1117#30** (refer to the test circuits,  
 $T_j = 0$  to  $125\text{ }^\circ\text{C}$ ,  $C_o = 10\text{ }\mu\text{F}$  unless otherwise specified)

Symbol	Parameter	Test Conditions	Min.	Typ.	Max.	Unit
$V_o$	Output Voltage	$V_{in} = 5\text{ V}$ $I_o = 10\text{ mA}$ $T_j = 25\text{ }^\circ\text{C}$	2.97	3	3.03	V
$V_o$	Output Voltage	$I_o = 0$ to $800\text{ mA}$ $V_{in} = 4.5$ to $10\text{ V}$	2.94		3.06	V
$\Delta V_o$	Line Regulation	$V_{in} = 4.5$ to $12\text{ V}$ $I_o = 0\text{ mA}$		1	6	mV
$\Delta V_o$	Load Regulation	$V_{in} = 4.5\text{ V}$ $I_o = 0$ to $800\text{ mA}$		1	10	mV
$\Delta V_o$	Temperature Stability			0.5		%
$\Delta V_o$	Long Term Stability	1000 hrs $T_j = 125\text{ }^\circ\text{C}$		0.3		%
$V_{in}$	Operating Input Voltage	$I_o = 100\text{ mA}$			15	V
$I_d$	Quiescent Current	$V_{in} \leq 12\text{ V}$		5	10	mA
$I_o$	Output Current	$V_{in} = 8\text{ V}$ $T_j = 25\text{ }^\circ\text{C}$	800	950	1200	mA
eN	Output Noise Voltage	$B = 10\text{ Hz}$ to $10\text{ KHz}$ $T_j = 25\text{ }^\circ\text{C}$		100		$\mu\text{V}$
SVR	Supply Voltage Rejection	$I_o = 40\text{ mA}$ $f = 120\text{ Hz}$ $T_j = 25\text{ }^\circ\text{C}$ $V_{in} = 6\text{ V}$ $V_{ripple} = 1\text{ Vpp}$	60	75		dB
$V_d$	Dropout Voltage	$I_o = 100\text{ mA}$ $I_o = 500\text{ mA}$ $I_o = 800\text{ mA}$		1 1.05 1.1	1.1 1.15 1.2	V V V
	Thermal Regulation	$T_a = 25\text{ }^\circ\text{C}$ 30ms Pulse		0.01	0.1	%/W

## LD1117 SERIES

**ELECTRICAL CHARACTERISTICS FOR LD1117#33** (refer to the test circuits,  
 $T_j = 0$  to  $125\text{ }^\circ\text{C}$ ,  $C_o = 10\text{ }\mu\text{F}$  unless otherwise specified)

Symbol	Parameter	Test Conditions	Min.	Typ.	Max.	Unit
$V_o$	Output Voltage	$V_{in} = 5.3\text{ V}$ $I_o = 10\text{ mA}$ $T_j = 25\text{ }^\circ\text{C}$	3.267	3.3	3.333	V
$V_o$	Output Voltage	$I_o = 0$ to $800\text{ mA}$ $V_{in} = 4.75$ to $10\text{ V}$	3.235		3.365	V
$\Delta V_o$	Line Regulation	$V_{in} = 4.75$ to $15\text{ V}$ $I_o = 0\text{ mA}$		1	6	mV
$\Delta V_o$	Load Regulation	$V_{in} = 4.75\text{ V}$ $I_o = 0$ to $800\text{ mA}$		1	10	mV
$\Delta V_o$	Temperature Stability			0.5		%
$\Delta V_o$	Long Term Stability	1000 hrs $T_j = 125\text{ }^\circ\text{C}$		0.3		%
$V_{in}$	Operating Input Voltage	$I_o = 100\text{ mA}$			15	V
$I_d$	Quiescent Current	$V_{in} \leq 15\text{ V}$		5	10	mA
$I_o$	Output Current	$V_{in} = 8.3\text{ V}$ $T_j = 25\text{ }^\circ\text{C}$	800	950	1200	mA
eN	Output Noise Voltage	$B = 10\text{ Hz}$ to $10\text{ KHz}$ $T_j = 25\text{ }^\circ\text{C}$		100		$\mu\text{V}$
SVR	Supply Voltage Rejection	$I_o = 40\text{ mA}$ $f = 120\text{ Hz}$ $T_j = 25\text{ }^\circ\text{C}$ $V_{in} = 6.3\text{ V}$ $V_{ripple} = 1\text{ Vpp}$	60	75		dB
$V_d$	Dropout Voltage	$I_o = 100\text{ mA}$		1	1.1	V
		$I_o = 500\text{ mA}$		1.05	1.15	V
		$I_o = 800\text{ mA}$		1.1	1.2	V
	Thermal Regulation	$T_a = 25\text{ }^\circ\text{C}$ 30ms Pulse		0.01	0.1	%/W

**ELECTRICAL CHARACTERISTICS FOR LD1117#50** (refer to the test circuits,  
 $T_j = 0$  to  $125\text{ }^\circ\text{C}$ ,  $C_o = 10\text{ }\mu\text{F}$  unless otherwise specified)

Symbol	Parameter	Test Conditions	Min.	Typ.	Max.	Unit
$V_o$	Output Voltage	$V_{in} = 7\text{ V}$ $I_o = 10\text{ mA}$ $T_j = 25\text{ }^\circ\text{C}$	4.95	5	5.05	V
$V_o$	Output Voltage	$I_o = 0$ to $800\text{ mA}$ $V_{in} = 6.5$ to $15\text{ V}$	4.9		5.1	V
$\Delta V_o$	Line Regulation	$V_{in} = 6.5$ to $15\text{ V}$ $I_o = 0\text{ mA}$		1	10	mV
$\Delta V_o$	Load Regulation	$V_{in} = 6.5\text{ V}$ $I_o = 0$ to $800\text{ mA}$		1	15	mV
$\Delta V_o$	Temperature Stability			0.5		%
$\Delta V_o$	Long Term Stability	1000 hrs $T_j = 125\text{ }^\circ\text{C}$		0.3		%
$V_{in}$	Operating Input Voltage	$I_o = 100\text{ mA}$			15	V
$I_d$	Quiescent Current	$V_{in} \leq 15\text{ V}$		5	10	mA
$I_o$	Output Current	$V_{in} = 10\text{ V}$ $T_j = 25\text{ }^\circ\text{C}$	800	950	1200	mA
eN	Output Noise Voltage	$B = 10\text{ Hz}$ to $10\text{ KHz}$ $T_j = 25\text{ }^\circ\text{C}$		100		$\mu\text{V}$
SVR	Supply Voltage Rejection	$I_o = 40\text{ mA}$ $f = 120\text{ Hz}$ $T_j = 25\text{ }^\circ\text{C}$ $V_{in} = 8\text{ V}$ $V_{ripple} = 1\text{ Vpp}$	60	75		dB
$V_d$	Dropout Voltage	$I_o = 100\text{ mA}$		1	1.1	V
		$I_o = 500\text{ mA}$		1.05	1.15	V
		$I_o = 800\text{ mA}$		1.1	1.2	V
	Thermal Regulation	$T_a = 25\text{ }^\circ\text{C}$ 30ms Pulse		0.01	0.1	%/W

**ELECTRICAL CHARACTERISTICS FOR LD1117(ADJUSTABLE)** (refer to the test circuits,  
 $T_j = 0$  to  $125\text{ }^\circ\text{C}$ ,  $C_o = 10\text{ }\mu\text{F}$  unless otherwise specified)

Symbol	Parameter	Test Conditions	Min.	Typ.	Max.	Unit
$V_{ref}$	Reference Voltage	$V_{in} - V_o = 2\text{ V}$ $I_o = 10\text{ mA}$ $T_j = 25\text{ }^\circ\text{C}$	1.238	1.25	1.262	V
$V_{ref}$	Reference Voltage	$I_o = 10$ to $800\text{ mA}$ $V_{in} - V_o = 1.4$ to $10\text{ V}$	1.225		1.275	V
$\Delta V_o$	Line Regulation	$V_{in} - V_o = 1.5$ to $13.75\text{ V}$ $I_o = 10\text{ mA}$		0.035	0.2	%
$\Delta V_o$	Load Regulation	$V_{in} - V_o = 3\text{ V}$ $I_o = 10$ to $800\text{ mA}$		0.1	0.4	%
$\Delta V_o$	Temperature Stability			0.5		%
$\Delta V_o$	Long Term Stability	1000 hrs $T_j = 125\text{ }^\circ\text{C}$		0.3		%
$V_{in}$	Operating Input Voltage				15	V
$I_{adj}$	Adjustment Pin Current	$V_{in} \leq 15\text{ V}$		60	120	$\mu\text{A}$
$\Delta I_{adj}$	Adjustment Pin Current Change	$V_{in} - V_o = 1.4$ to $10\text{ V}$ $I_o = 10$ to $800\text{ mA}$		1	5	$\mu\text{A}$
$I_{o(min)}$	Minimum Load Current	$V_{in} = 15\text{ V}$		2	5	mA
$I_o$	Output Current	$V_{in} - V_o = 5\text{ V}$ $T_j = 25\text{ }^\circ\text{C}$	800	950	1200	mA
eN	Output Noise (% $V_o$ )	$B = 10\text{ Hz}$ to $10\text{ KHz}$ $T_j = 25\text{ }^\circ\text{C}$		0.003		%
SVR	Supply Voltage Rejection	$I_o = 40\text{ mA}$ $f = 120\text{ Hz}$ $T_j = 25\text{ }^\circ\text{C}$ $V_{in} - V_o = 3\text{ V}$ $V_{ripple} = 1\text{ Vpp}$	60	75		dB
$V_d$	Dropout Voltage	$I_o = 100\text{ mA}$ $I_o = 500\text{ mA}$ $I_o = 800\text{ mA}$		1 1.05 1.1	1.1 1.15 1.2	V V V
	Thermal Regulation	$T_a = 25\text{ }^\circ\text{C}$ 30ms Pulse		0.01	0.1	%/W

**ELECTRICAL CHARACTERISTICS FOR LD1117#18C** (refer to the test circuits,  
 $T_j = 0$  to  $125\text{ }^\circ\text{C}$ ,  $C_o = 10\text{ }\mu\text{F}$  unless otherwise specified)

Symbol	Parameter	Test Conditions	Min.	Typ.	Max.	Unit
$V_o$	Output Voltage	$V_{in} = 3.8\text{ V}$ $I_o = 10\text{ mA}$ $T_j = 25\text{ }^\circ\text{C}$	1.76	1.8	1.84	V
$V_o$	Output Voltage	$I_o = 0$ to $800\text{ mA}$ $V_{in} = 3.9$ to $10\text{ V}$	1.73		1.87	V
$\Delta V_o$	Line Regulation	$V_{in} = 3.3$ to $8\text{ V}$ $I_o = 0\text{ mA}$		1	30	mV
$\Delta V_o$	Load Regulation	$V_{in} = 3.3\text{ V}$ $I_o = 0$ to $800\text{ mA}$		1	30	mV
$\Delta V_o$	Temperature Stability			0.5		%
$\Delta V_o$	Long Term Stability	1000 hrs $T_j = 125\text{ }^\circ\text{C}$		0.3		%
$V_{in}$	Operating Input Voltage	$I_o = 100\text{ mA}$			10	V
$I_d$	Quiescent Current	$V_{in} \leq 8\text{ V}$		5	10	mA
$I_o$	Output Current	$V_{in} = 6.8\text{ V}$ $T_j = 25\text{ }^\circ\text{C}$	800	950	1200	mA
eN	Output Noise Voltage	$B = 10\text{ Hz}$ to $10\text{ KHz}$ $T_j = 25\text{ }^\circ\text{C}$		100		$\mu\text{V}$
SVR	Supply Voltage Rejection	$I_o = 40\text{ mA}$ $f = 120\text{ Hz}$ $T_j = 25\text{ }^\circ\text{C}$ $V_{in} = 5.5\text{ V}$ $V_{ripple} = 1\text{ Vpp}$	60	75		dB
$V_d$	Dropout Voltage	$I_o = 100\text{ mA}$ $I_o = 500\text{ mA}$ $I_o = 800\text{ mA}$		1 1.05 1.1	1.1 1.15 1.2	V V V
	Thermal Regulation	$T_a = 25\text{ }^\circ\text{C}$ 30ms Pulse		0.01	0.1	%/W



## LD1117 SERIES

**ELECTRICAL CHARACTERISTICS FOR LD1117#25C** (refer to the test circuits,  
 $T_j = 0$  to  $125\text{ }^\circ\text{C}$ ,  $C_o = 10\text{ }\mu\text{F}$  unless otherwise specified)

Symbol	Parameter	Test Conditions	Min.	Typ.	Max.	Unit
$V_o$	Output Voltage	$V_{in} = 4.5\text{ V}$ $I_o = 10\text{ mA}$ $T_j = 25\text{ }^\circ\text{C}$	2.45	2.5	2.55	V
$V_o$	Output Voltage	$I_o = 0$ to $800\text{ mA}$ $V_{in} = 3.9$ to $10\text{ V}$	2.4		2.6	V
$\Delta V_o$	Line Regulation	$V_{in} = 3.9$ to $10\text{ V}$ $I_o = 0\text{ mA}$		1	30	mV
$\Delta V_o$	Load Regulation	$V_{in} = 3.9\text{ V}$ $I_o = 0$ to $800\text{ mA}$		1	30	mV
$\Delta V_o$	Temperature Stability			0.5		%
$\Delta V_o$	Long Term Stability	1000 hrs $T_j = 125\text{ }^\circ\text{C}$		0.3		%
$V_{in}$	Operating Input Voltage	$I_o = 100\text{ mA}$			15	V
$I_d$	Quiescent Current	$V_{in} \leq 10\text{ V}$		5	10	mA
$I_o$	Output Current	$V_{in} = 7.5\text{ V}$ $T_j = 25\text{ }^\circ\text{C}$	800	950	1200	mA
eN	Output Noise Voltage	$B = 10\text{ Hz}$ to $10\text{ KHz}$ $T_j = 25\text{ }^\circ\text{C}$		100		$\mu\text{V}$
SVR	Supply Voltage Rejection	$I_o = 40\text{ mA}$ $f = 120\text{ Hz}$ $T_j = 25\text{ }^\circ\text{C}$ $V_{in} = 5.5\text{ V}$ $V_{ripple} = 1\text{ Vpp}$	60	75		dB
$V_d$	Dropout Voltage	$I_o = 100\text{ mA}$		1	1.1	V
		$I_o = 500\text{ mA}$		1.05	1.15	V
		$I_o = 800\text{ mA}$		1.1	1.2	V
	Thermal Regulation	$T_a = 25\text{ }^\circ\text{C}$ 30ms Pulse		0.01	0.1	%/W

**ELECTRICAL CHARACTERISTICS FOR LD1117#30C** (refer to the test circuits,  
 $T_j = 0$  to  $125\text{ }^\circ\text{C}$ ,  $C_o = 10\text{ }\mu\text{F}$  unless otherwise specified)

Symbol	Parameter	Test Conditions	Min.	Typ.	Max.	Unit
$V_o$	Output Voltage	$V_{in} = 5\text{ V}$ $I_o = 10\text{ mA}$ $T_j = 25\text{ }^\circ\text{C}$	2.94	3	3.06	V
$V_o$	Output Voltage	$I_o = 0$ to $800\text{ mA}$ $V_{in} = 4.5$ to $10\text{ V}$	2.88		3.12	V
$\Delta V_o$	Line Regulation	$V_{in} = 4.5$ to $12\text{ V}$ $I_o = 0\text{ mA}$		1	30	mV
$\Delta V_o$	Load Regulation	$V_{in} = 4.5\text{ V}$ $I_o = 0$ to $800\text{ mA}$		1	30	mV
$\Delta V_o$	Temperature Stability			0.5		%
$\Delta V_o$	Long Term Stability	1000 hrs $T_j = 125\text{ }^\circ\text{C}$		0.3		%
$V_{in}$	Operating Input Voltage	$I_o = 100\text{ mA}$			15	V
$I_d$	Quiescent Current	$V_{in} \leq 12\text{ V}$		5	10	mA
$I_o$	Output Current	$V_{in} = 8\text{ V}$ $T_j = 25\text{ }^\circ\text{C}$	800	950	1200	mA
eN	Output Noise Voltage	$B = 10\text{ Hz}$ to $10\text{ KHz}$ $T_j = 25\text{ }^\circ\text{C}$		100		$\mu\text{V}$
SVR	Supply Voltage Rejection	$I_o = 40\text{ mA}$ $f = 120\text{ Hz}$ $T_j = 25\text{ }^\circ\text{C}$ $V_{in} = 6\text{ V}$ $V_{ripple} = 1\text{ Vpp}$	60	75		dB
$V_d$	Dropout Voltage	$I_o = 100\text{ mA}$		1	1.1	V
		$I_o = 500\text{ mA}$		1.05	1.15	V
		$I_o = 800\text{ mA}$		1.1	1.2	V
	Thermal Regulation	$T_a = 25\text{ }^\circ\text{C}$ 30ms Pulse		0.01	0.1	%/W

**ELECTRICAL CHARACTERISTICS FOR LD1117#33C** (refer to the test circuits,  
 $T_j = 0$  to  $125\text{ }^\circ\text{C}$ ,  $C_o = 10\text{ }\mu\text{F}$  unless otherwise specified)

Symbol	Parameter	Test Conditions	Min.	Typ.	Max.	Unit
$V_o$	Output Voltage	$V_{in} = 5.3\text{ V}$ $I_o = 10\text{ mA}$ $T_j = 25\text{ }^\circ\text{C}$	3.24	3.3	3.36	V
$V_o$	Output Voltage	$I_o = 0$ to $800\text{ mA}$ $V_{in} = 4.75$ to $10\text{ V}$	3.16		3.44	V
$\Delta V_o$	Line Regulation	$V_{in} = 4.75$ to $15\text{ V}$ $I_o = 0\text{ mA}$		1	30	mV
$\Delta V_o$	Load Regulation	$V_{in} = 4.75\text{ V}$ $I_o = 0$ to $800\text{ mA}$		1	30	mV
$\Delta V_o$	Temperature Stability			0.5		%
$\Delta V_o$	Long Term Stability	1000 hrs $T_j = 125\text{ }^\circ\text{C}$		0.3		%
$V_{in}$	Operating Input Voltage	$I_o = 100\text{ mA}$			15	V
$I_d$	Quiescent Current	$V_{in} \leq 15\text{ V}$		5	10	mA
$I_o$	Output Current	$V_{in} = 8.3\text{ V}$ $T_j = 25\text{ }^\circ\text{C}$	800	950	1200	mA
eN	Output Noise Voltage	$B = 10\text{ Hz}$ to $10\text{ KHz}$ $T_j = 25\text{ }^\circ\text{C}$		100		$\mu\text{V}$
SVR	Supply Voltage Rejection	$I_o = 40\text{ mA}$ $f = 120\text{ Hz}$ $T_j = 25\text{ }^\circ\text{C}$ $V_{in} = 6.3\text{ V}$ $V_{ripple} = 1\text{ Vpp}$	60	75		dB
$V_d$	Dropout Voltage	$I_o = 100\text{ mA}$ $I_o = 500\text{ mA}$ $I_o = 800\text{ mA}$		1 1.05 1.1	1.1 1.15 1.2	V V V
	Thermal Regulation	$T_a = 25\text{ }^\circ\text{C}$ 30ms Pulse		0.01	0.1	%/W

**ELECTRICAL CHARACTERISTICS FOR LD1117#50C** (refer to the test circuits,  
 $T_j = 0$  to  $125\text{ }^\circ\text{C}$ ,  $C_o = 10\text{ }\mu\text{F}$  unless otherwise specified)

Symbol	Parameter	Test Conditions	Min.	Typ.	Max.	Unit
$V_o$	Output Voltage	$V_{in} = 7\text{ V}$ $I_o = 10\text{ mA}$ $T_j = 25\text{ }^\circ\text{C}$	4.9	5	5.1	V
$V_o$	Output Voltage	$I_o = 0$ to $800\text{ mA}$ $V_{in} = 6.5$ to $15\text{ V}$	4.8		5.2	V
$\Delta V_o$	Line Regulation	$V_{in} = 6.5$ to $15\text{ V}$ $I_o = 0\text{ mA}$		1	50	mV
$\Delta V_o$	Load Regulation	$V_{in} = 6.5\text{ V}$ $I_o = 0$ to $800\text{ mA}$		1	50	mV
$\Delta V_o$	Temperature Stability			0.5		%
$\Delta V_o$	Long Term Stability	1000 hrs $T_j = 125\text{ }^\circ\text{C}$		0.3		%
$V_{in}$	Operating Input Voltage	$I_o = 100\text{ mA}$			15	V
$I_d$	Quiescent Current	$V_{in} \leq 15\text{ V}$		5	10	mA
$I_o$	Output Current	$V_{in} = 10\text{ V}$ $T_j = 25\text{ }^\circ\text{C}$	800	950	1200	mA
eN	Output Noise Voltage	$B = 10\text{ Hz}$ to $10\text{ KHz}$ $T_j = 25\text{ }^\circ\text{C}$		100		$\mu\text{V}$
SVR	Supply Voltage Rejection	$I_o = 40\text{ mA}$ $f = 120\text{ Hz}$ $T_j = 25\text{ }^\circ\text{C}$ $V_{in} = 8\text{ V}$ $V_{ripple} = 1\text{ Vpp}$	60	75		dB
$V_d$	Dropout Voltage	$I_o = 100\text{ mA}$ $I_o = 500\text{ mA}$ $I_o = 800\text{ mA}$		1 1.05 1.1	1.1 1.15 1.2	V V V
	Thermal Regulation	$T_a = 25\text{ }^\circ\text{C}$ 30ms Pulse		0.01	0.1	%/W

## LD1117 SERIES

### TYPICAL APPLICATIONS:

**FIGURE 1:** Negative Supply

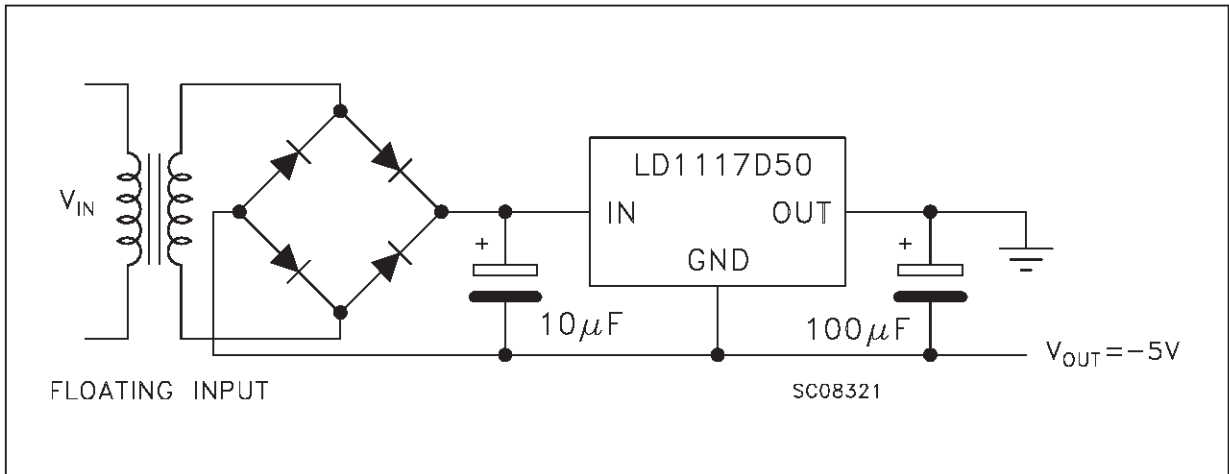

**FIGURE 2:** Active Terminator for SCSI-2 BUS

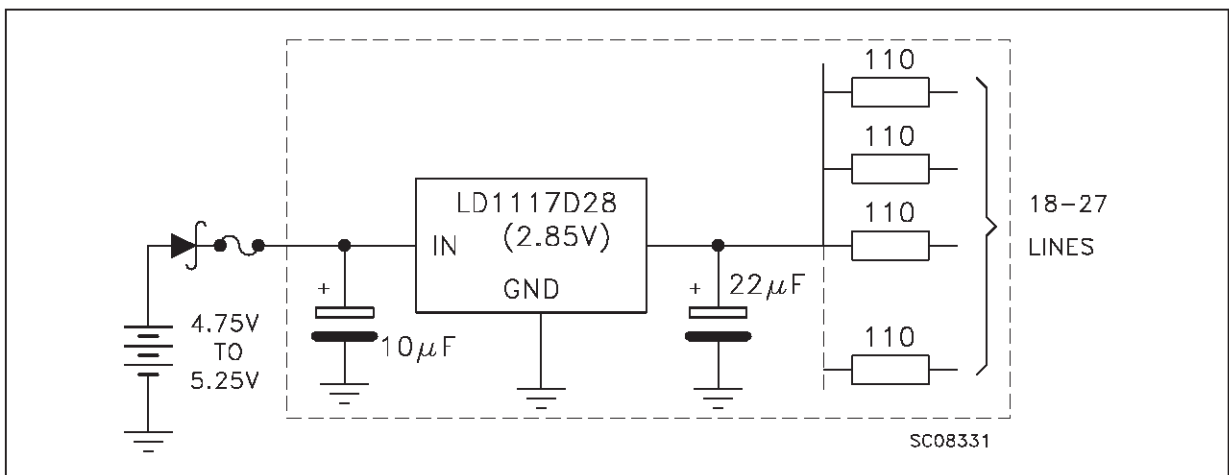

**FIGURE 3:** Circuit for Increasing Output Voltage

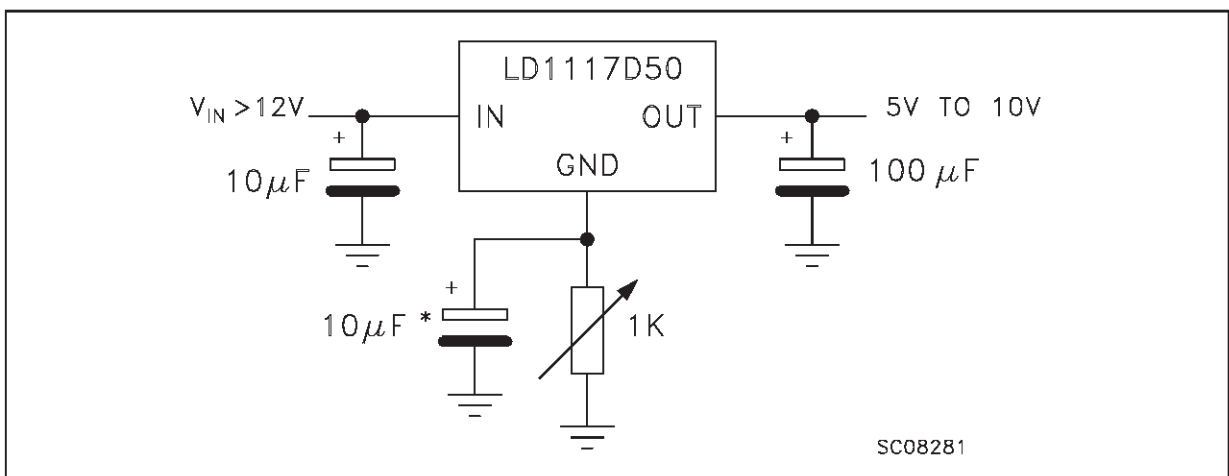

TYPICAL APPLICATIONS (continued):

FIGURE 4: Voltage Regulator With Reference

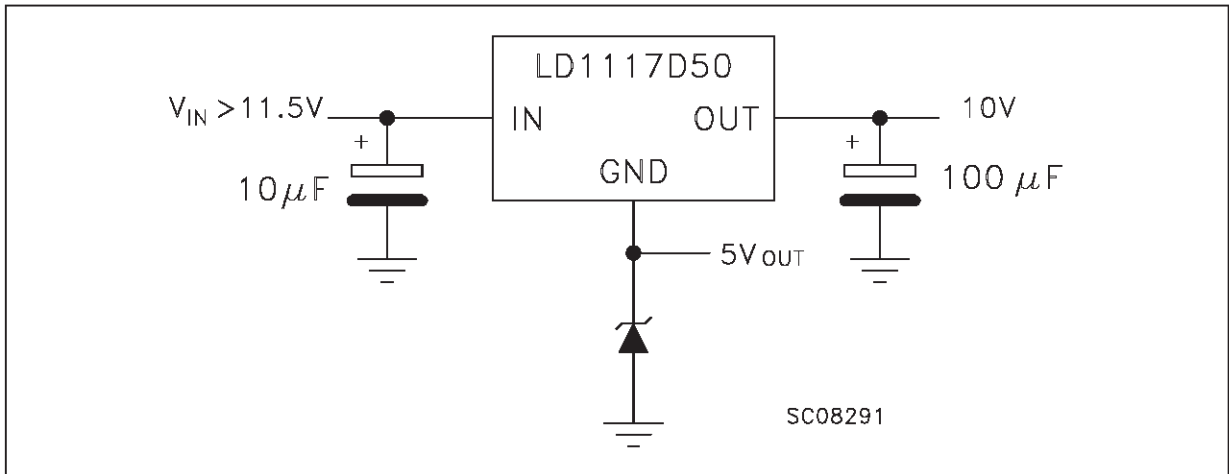
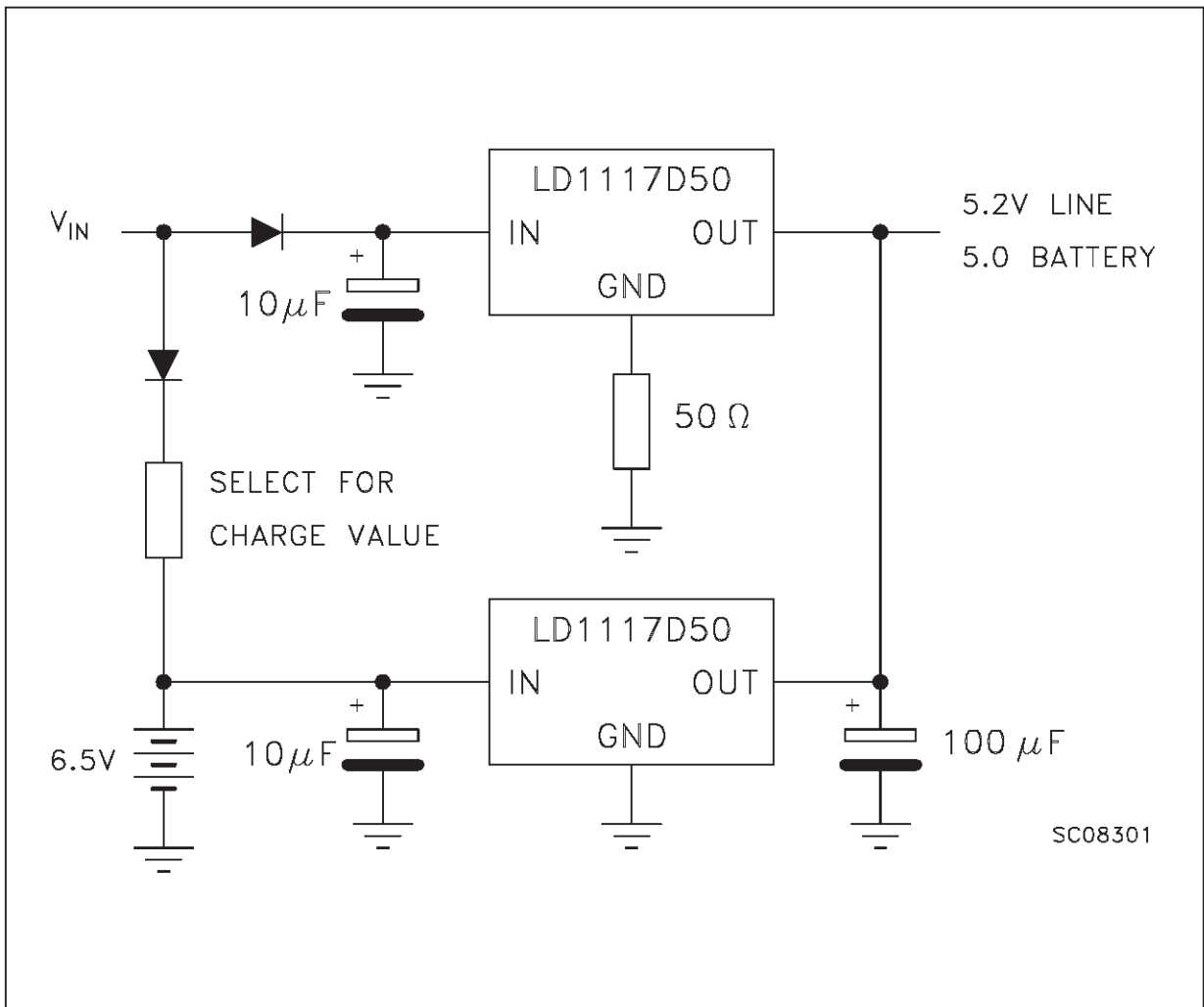

FIGURE 5: Battery Backed-up Regulated Supply





**LD1117 ADJUSTABLE: APPLICATION NOTE**

The LD1117 ADJUSTABLE has a thermal stabilized  $1.25 \pm 0.012V$  reference voltage between the OUT and ADJ pins.  $I_{ADJ}$  is  $60\mu A$  typ. ( $120\mu A$  max.) and  $\Delta I_{ADJ}$  is  $1\mu A$  typ. ( $5\mu A$  max.).

$R1$  is normally fixed to  $120\Omega$ . From figure 7 we obtain:

$$V_{OUT} = V_{REF} + R2 (I_{ADJ} + I_{R1}) = V_{REF} + R2 (I_{ADJ} + V_{REF} / R1) = V_{REF} (1 + R2 / R1) + R2 \times I_{ADJ}.$$

In normal application  $R2$  value is in the range of few Kohm, so the  $R2 \times I_{DJ}$  product could not be considered in the  $V_{OUT}$  calculation; then the above expression becomes:

$$V_{OUT} = V_{REF} (1 + R2 / R1).$$

In order to have the better load regulation it is important to realize a good Kelvin connection of  $R1$  and  $R2$  resistors. In particular  $R1$  connection must be realized very close to OUT and ADJ pin, while  $R2$  ground connection must be placed as near as possible to the negative Load pin. Ripple rejection can be improved by introducing a  $10\mu F$  electrolytic capacitor placed in parallel to the  $R2$  resistor (see Fig.8)

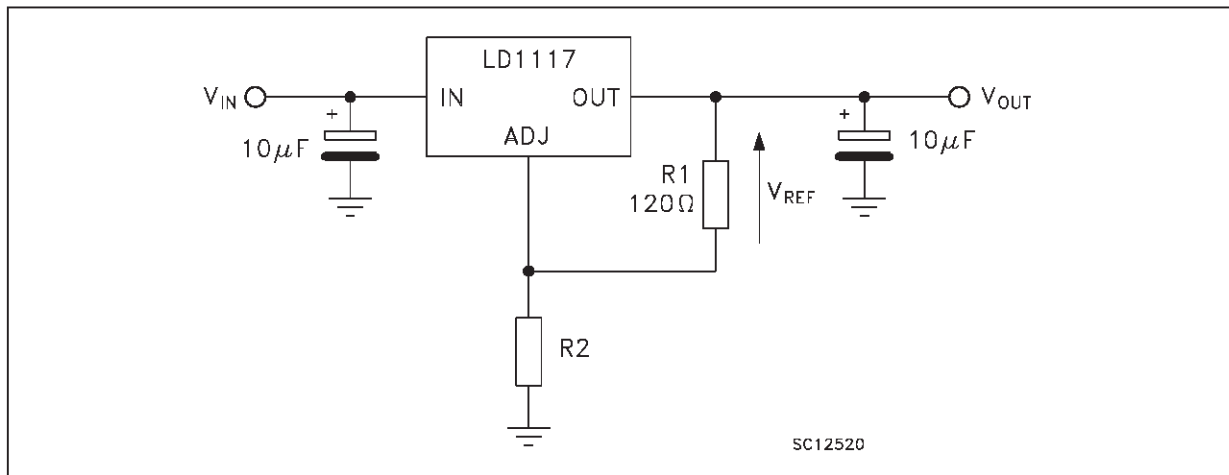
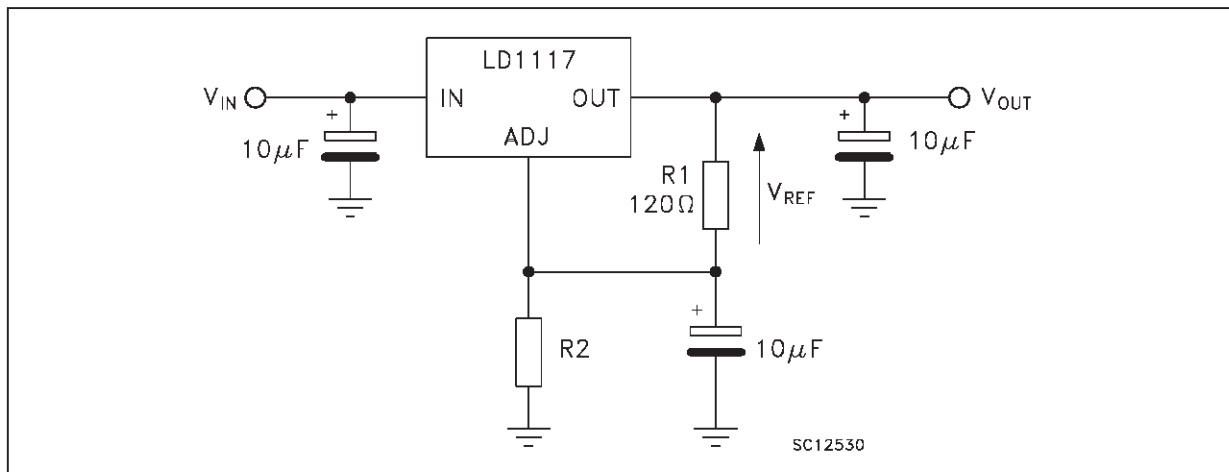
**FIGURE 7:** Adjustable Output Voltage Application Circuit**FIGURE 8:** Adjustable Output Voltage Application with improved Ripple Rejection

**TO-220 MECHANICAL DATA**

DIM.	mm			inch		
	MIN.	TYP.	MAX.	MIN.	TYP.	MAX.
A	4.40		4.60	0.173		0.181
C	1.23		1.32	0.048		0.051
D	2.40		2.72	0.094		0.107
D1		1.27			0.050	
E	0.49		0.70	0.019		0.027
F	0.61		0.88	0.024		0.034
F1	1.14		1.70	0.044		0.067
F2	1.14		1.70	0.044		0.067
G	4.95		5.15	0.194		0.203
G1	2.4		2.7	0.094		0.106
H2	10.0		10.40	0.393		0.409
L2		16.4			0.645	
L4	13.0		14.0	0.511		0.551
L5	2.65		2.95	0.104		0.116
L6	15.25		15.75	0.600		0.620
L7	6.2		6.6	0.244		0.260
L9	3.5		3.93	0.137		0.154
DIA.	3.75		3.85	0.147		0.151

