



COIL SPRING COMPRESSING STATION - HYDRAULIC 1500kg CAPACITY

MODEL NO: RE231.V3

Thank you for purchasing a Sealey product. Manufactured to a high standard, this product will, if used according to these instructions and maintained properly, give you years of trouble free performance.

IMPORTANT: PLEASE READ THESE INSTRUCTIONS CAREFULLY. NOTE THE SAFE OPERATIONAL REQUIREMENTS, WARNINGS & CAUTIONS. USE THE PRODUCT CORRECTLY AND WITH CARE FOR THE PURPOSE FOR WHICH IT IS INTENDED. FAILURE TO DO SO MAY CAUSE DAMAGE AND/OR PERSONAL INJURY AND WILL INVALIDATE THE WARRANTY. KEEP THESE INSTRUCTIONS SAFE FOR FUTURE USE.



Refer to Instruction Manual



Wear a Face Shield



Wear Safety Footwear



Wear Protective Clothing



No Reaching In

1. SAFETY

- WARNING!** Ensure Health & Safety, local authority, and general workshop practice regulations are adhered to when using this equipment
- WARNING!** Wear approved safety hand and eye protection (standard spectacles are not adequate).
- WARNING! TRAPPING DANGER** – Keep hands and fingers away from the spring and compressing jaws in use.
- ✓ Keep the work area clean, uncluttered and ensure there is adequate lighting.
- ✓ Maintain correct balance and footing. Ensure the floor is not slippery and wear non-slip shoes.
- ✓ Remove ill-fitting clothes. Remove ties, watches, rings, other loose jewellery. Contain and/or tie back long hair.
- ✓ Wear appropriate protective clothing.
- ✓ Familiarise yourself with the applications, limitations and potential hazards of the spring compressor.
- ✗ **DO NOT** force the spring compressor to achieve a task it was not designed to perform.
- ✗ **DO NOT** allow untrained persons to use the spring compressor.
- ✓ Strut and Spring Compression station should be securely bolted to the workshop floor before use.
- ✓ Apply grease to the front and rear faces of the main upright to assist the smooth action of the compressor.
- ✗ **DO NOT** operate spring compressor if parts are damaged or missing as this may cause failure and/or personal injury.
- ✓ Before commencing compression, make visual inspection of machine to ensure pins are securely positioned and that there is no sign of wear or fatigue – if found; **DO NOT** use the unit and refer to your local Sealey stockist for advice and replacement parts.
- ✓ Ensure jaw locating pins are properly positioned and safety clips are attached correctly.
- ✓ Before commencing compression of spring, ensure coils of the spring are seated securely in the jaws of the compressor and cannot slide out during compression.
- ✓ Always fit the safety chain around strut and spring (ensure that the chain is not trapped in the coils of the spring).
- ✓ When applying compression to the spring, always stand to one side of the unit.
- ▲ **DANGER!** Stop compressing the spring before the coils touch.
- ✓ Before attempting to remove top cap nut, always use a metal or wooden item to test if the compression has been relieved. **DO NOT** use your hands / fingers.
- ✓ Sealey recommends the use of purpose made strut tools to remove the top-nut from the damper.
- ✓ Once compressed, and the strut removed, we recommend releasing the tension on the spring. **DO NOT** leave the spring under compression in the machine unattended and **DO NOT** leave in compression for prolonged periods, i.e. overnight.
- ✓ Before releasing the compression ensure that the top strut-nut is securely fastened to the maker's tolerance.
- ✓ Release the compression slowly, keeping your hands and fingers away from the spring assembly.
- ✓ Be sure that the tension on the spring is fully controlled by the strut assembly before removing it from the jaws of the compressor.
- ✓ When not in use, clean and store the spring compressor in a safe, dry, childproof location.
- ✓ Maintain the spring compressor in good condition. Replace damaged parts. *Use genuine parts only. Unauthorised parts may be dangerous and will invalidate the warranty.*
- WARNING!** The warnings, cautions and instructions in this manual cannot cover all possible conditions and situations that may occur. It must be understood by the operator that common sense and caution are factors which cannot be built into this product, but must be applied by the operator.

2. INTRODUCTION

1500kg Foot operated hydraulic unit. Quicker and easier than using ratchet driven spring compressor. Plastic coated yokes reduce the risk of spring slippage or damage and are suitable for springs from Ø80mm to Ø175mm.

3. SPECIFICATION

Model No:	RE231.V3
Maximum Load:	1500kg
Upper Yoke Positions:	7
Lower Yoke Travel:	340mm
Spring Diameter:	Ø80-175mm
Actuation:	Foot Pedal

4. ASSEMBLY

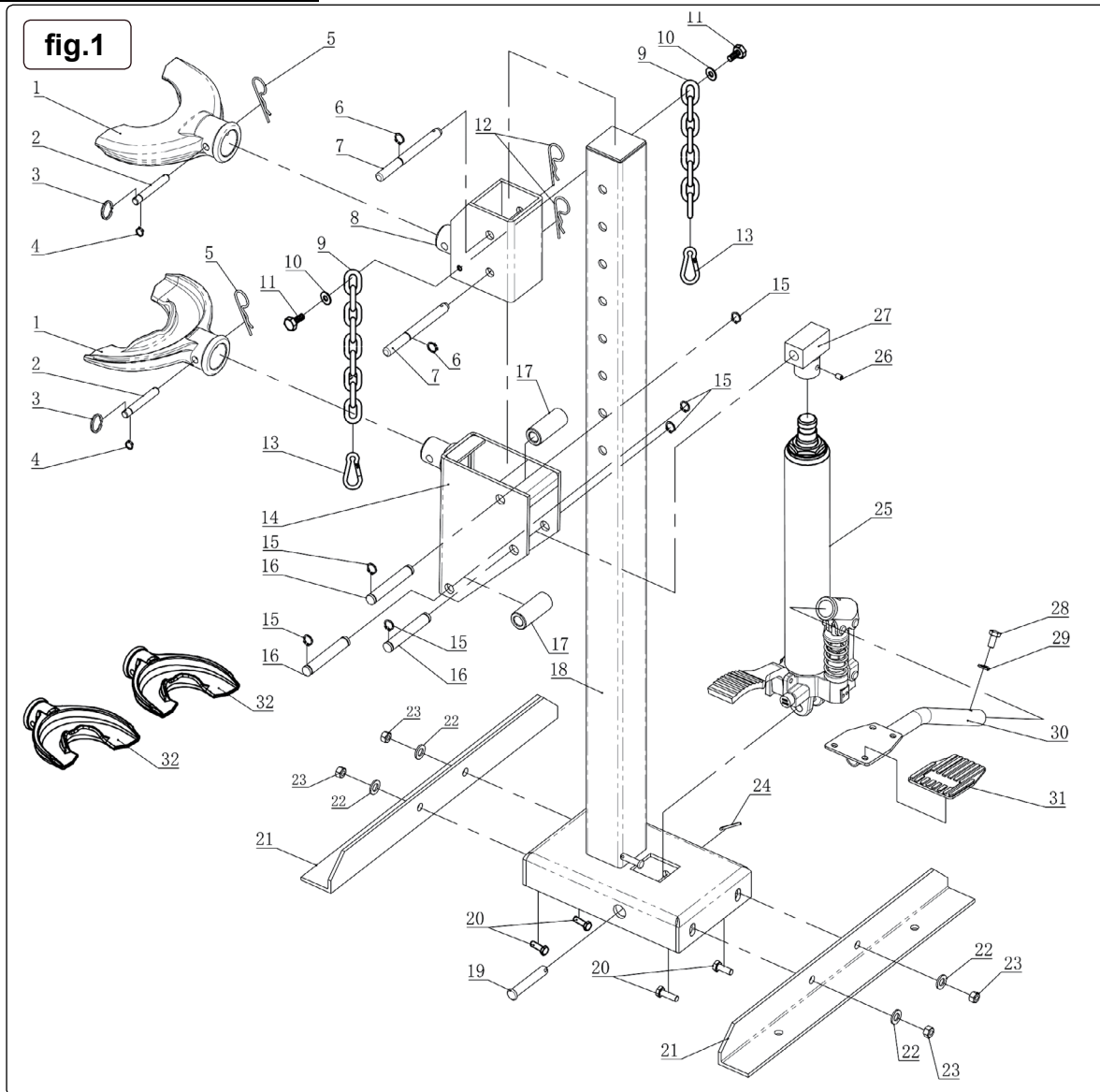

- 4.1. Attach the brackets (fig.1.21) to the base using the fixings shown.
- 4.2. Attach the pedal (fig.1.30) to the pump (fig.1.25) and secure.
- 4.3. **IMPORTANT:** secure the machine to the floor .The brackets are drilled to accept bolts which should be secured to suitable fixings

5. OPERATION

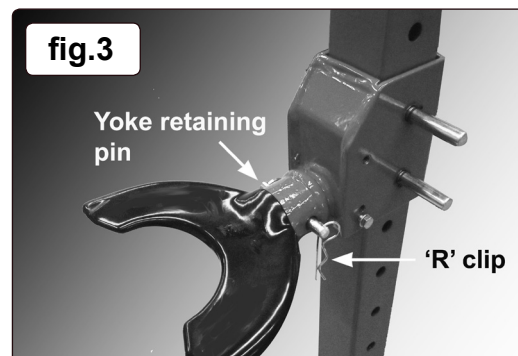
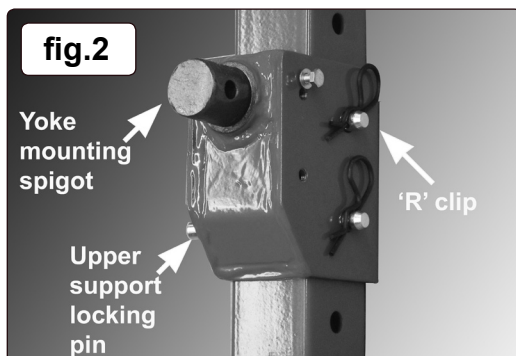

- 5.1. **Mounting the yokes**
 - 5.1.1. Push the required yoke onto the yoke mounting spigot (fig.2).
 - 5.1.2. Secure with the yoke retaining pin and insert the 'R' clip.
 - 5.1.3. Repeat to secure the lower yoke.
 - 5.1.4. Make sure that the yokes are installed with the bottom yoke facing up and the top yoke facing down.
- 5.2. **Spring compressing**
 - 5.2.1. Move the upper support to the required height in order to accommodate the spring. Do this by releasing the two upper support locking pins (fig.2/fig.1.7), moving the support and replacing the pins, ensuring that the 'R' clips are inserted.
 - 5.2.2. Place the spring between the yokes and wrap the safety chains around the spring. Position one chain around a coil protruding above the top yoke and the other chain below the bottom yoke (fig.3). Check that neither chain could be trapped between the coils. Ensure that the chains are as tight as possible.

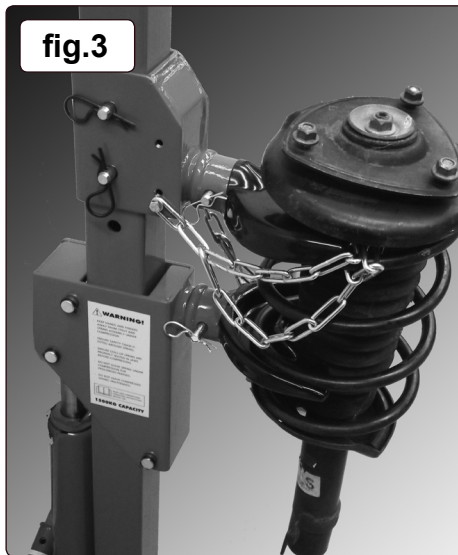

- 5.2.3. Apply light hydraulic pressure with the pump pedal and check that the spring is seated correctly.
- 5.2.4. If the spring is seated correctly, continue to compress the spring, standing to the side of the machine.
- 5.2.5. Compress the spring gradually, making sure that the spring stays seated in the yokes.
- 5.2.6. When compressing conical springs; the centre line of the spring should remain parallel to the compressor body.
- 5.2.7. **DO NOT** compress the spring until the coils touch, only compress until the top nut is free.
 - ❑ **WARNING:** Check that the nut is free by using a metal or wooden item, **DO NOT** check with fingers or hands.
- 5.2.8. It is recommended that a purpose-made strut nut socket is used to remove the nut. Support the shock absorber to prevent it falling clear when released.
- 5.2.9. **DO NOT** leave the spring compressed with the machine unattended; release the pressure on the spring if it is to be left for any time.
- 5.2.10. Decompress the spring by pressing the release valve pedal (next to the pump pedal) gradually.
- 5.2.11. To rebuild the strut assembly, compress the spring and insert the shock absorber through the lower yoke and reattach the top plate and nut.
- 5.2.12. Check that the top nut is tightened to the manufacturer's torque setting.
- 5.2.13. Release the compression slowly, keeping hands well away from the spring.
- 5.2.14. Ensure that the spring tension is constrained by the strut assembly before releasing it from the yokes of the spring compressor.

6. MAINTENANCE

- 6.1. Before each use, check the compressor to ensure it is not damaged or worn. If in any doubt **DO NOT** use the unit. Remove it from service immediately and contact your local Sealey stockist for advice/repairs.
- 6.2. Refilling the hydraulic system with oil is rarely necessary but the level should be checked in the event of a loss of performance. To check oil level, ensure the ram is fully lowered, remove filler plug and check that level is within 10mm of filler hole. Add hydraulic jack oil if necessary.
 - NOTE:** Use a good quality jack oil, such as SEALEY HYDRAULIC JACK OIL.
 - ❑ **WARNING:** **DO NOT** use brake fluid, or any fluid other than hydraulic jack oil as this will cause serious damage and will invalidate the warranty!

ENVIRONMENT PROTECTION



Recycle unwanted materials instead of disposing of them as waste. All tools, accessories and packaging should be sorted, taken to a recycling centre and disposed of in a manner which is compatible with the environment. When the product becomes completely unserviceable and requires disposal, drain any fluids (if applicable) into approved containers and dispose of the product and fluids according to local regulations.

Note: It is our policy to continually improve products and as such we reserve the right to alter data, specifications and component parts without prior notice.

Important: No Liability is accepted for incorrect use of this product.

Warranty: Guarantee is 12 months from purchase date, proof of which is required for any claim.

Sealey Group, Kempson Way, Suffolk Business Park, Bury St Edmunds, Suffolk. IP32 7AR



01284 757500



01284 703534



sales@sealey.co.uk



www.sealey.co.uk