



INSTRUCTIONS FOR
FLOOR STANDING METAL FOLDER
 MODEL NO: **DF910.V2**

Thank you for purchasing a Sealey product. Manufactured to a high standard, this product will, if used according to these instructions, and properly maintained, give you years of trouble free performance.

IMPORTANT: PLEASE READ THESE INSTRUCTIONS CAREFULLY. NOTE THE SAFE OPERATIONAL REQUIREMENTS, WARNINGS & CAUTIONS. USE THE PRODUCT CORRECTLY AND WITH CARE FOR THE PURPOSE FOR WHICH IT IS INTENDED. FAILURE TO DO SO MAY CAUSE DAMAGE AND/OR PERSONAL INJURY AND WILL INVALIDATE THE WARRANTY. KEEP THESE INSTRUCTIONS SAFE FOR FUTURE USE.



Refer to instruction manual



Wear eye protection



Wear protective gloves

1. SAFETY

- ✓ Wear approved safety goggles and protective gloves when operating the folder. Your local Sealey stockist offers a complete range of safety equipment.
- ✓ Use the tool only for its intended purpose.
- ✓ Check regularly for damaged parts. **DO NOT** use if any components are broken, worn or damaged.
- ✓ Use original Sealey spare parts and accessories. Use of non-recommended spare parts may be dangerous and will invalidate warranty.
- ✗ **DO NOT** operate this tool while under the influence of drugs, alcohol or other impairing medication.
- ✗ **DO NOT** allow unqualified persons to operate the metal folder. Keep children away from the tool.

2. INTRODUCTION

Floor standing metal folder with 910mm capacity. Manually operated and suitable for folding up to 0.8mm sheet.

3. SPECIFICATION

Model no: DF910.V2
 Maximum sheet size: 910mm
 Maximum sheet thickness: 0.8mm
 Maximum diameter of steel rod: 2mm
 Maximum width of 2mm strip or 2mm diameter steel rod: 100mm
 Note: when bending 2mm strip or 2mm diameter steel rod, they must be placed close to one of the set screws.
 Weight: 28kg

4. CONTENTS

Unpack the unit and check that all parts are included and not damaged. Should you experience a problem contact your supplier immediately.
 Contents: 1x Main frame. 2 x Cross bars. 1 x Folding plate. 1 x Foot stand. 1 x Bag of nuts/Bolts consisting of: 2 x Set screws (L-shaped), 6 x Bolts, 6 x Nuts, 6 x Washers.



5. ASSEMBLY

- 5.1. Lay the folder main frame (fig 1. A) on the floor with the top folding plate (fig1.1) uppermost.
- 5.2. Attach the foot stand (3) to the legs of the main frame (A) using the nuts, bolts and washers supplied. The foot stand cross bar (3) must be facing uppermost when the main frame is on the floor.
- 5.3. Ensure the support brackets (4) are secured to the outside of the main frame legs and the outside of the foot stand.
- 5.4. Fully tighten all nuts and bolts.
- 5.5. Attach the top plate using the L-shaped set screws (2).
- 5.6. Raise assembled folder to upright position so the foot stand cross bar (3) and lift top folding plate (1) are to the front of the unit.

6. OPERATION

- 6.1. Screw the two adjusting nuts (B) down to ensure the folding plates (C) are parallel. This may require further adjustment from time to time.
- 6.2. Insert a test piece of sheet metal in the folder.
- 6.3. Secure the metal between the folding lips by tightening the two clamps, whilst ensuring there is even pressure on both ends.
- 6.4. Place your foot on the base cross bar (3).
- 6.5. Raise the top folding plate (1) to create the fold. From this test, you will be able to determine how and where the fold appears.
- 6.6. When satisfied with the test results, proceed with the actual workpiece.
- 6.7. Repeat the above steps 3.2 - 3.5 for each new workpiece.

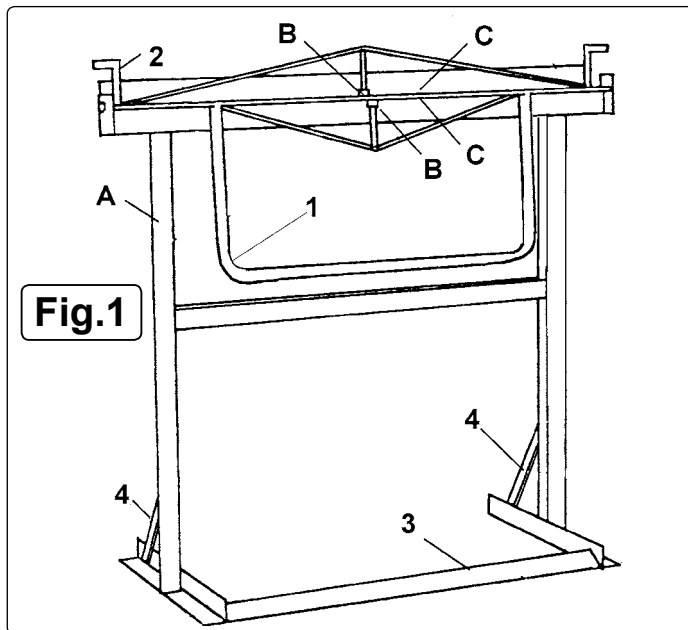

ENVIRONMENT PROTECTION

Recycle unwanted materials instead of disposing of them as waste. All tools, accessories and packaging should be sorted, taken to a recycling centre and disposed of in a manner which is compatible with the environment. When the product becomes completely unserviceable and requires disposal, drain any fluids (if applicable) into approved containers and dispose of the product and fluids according to local regulations.

Note: It is our policy to continually improve products and as such we reserve the right to alter data, specifications and component parts without prior notice.

Important: No Liability is accepted for incorrect use of this product.

Warranty: Guarantee is 12 months from purchase date, proof of which is required for any claim.

Sealey Group, Kempson Way, Suffolk Business Park, Bury St Edmunds, Suffolk. IP32 7AR



01284 757500



01284 703534



sales@sealey.co.uk



www.sealey.co.uk