

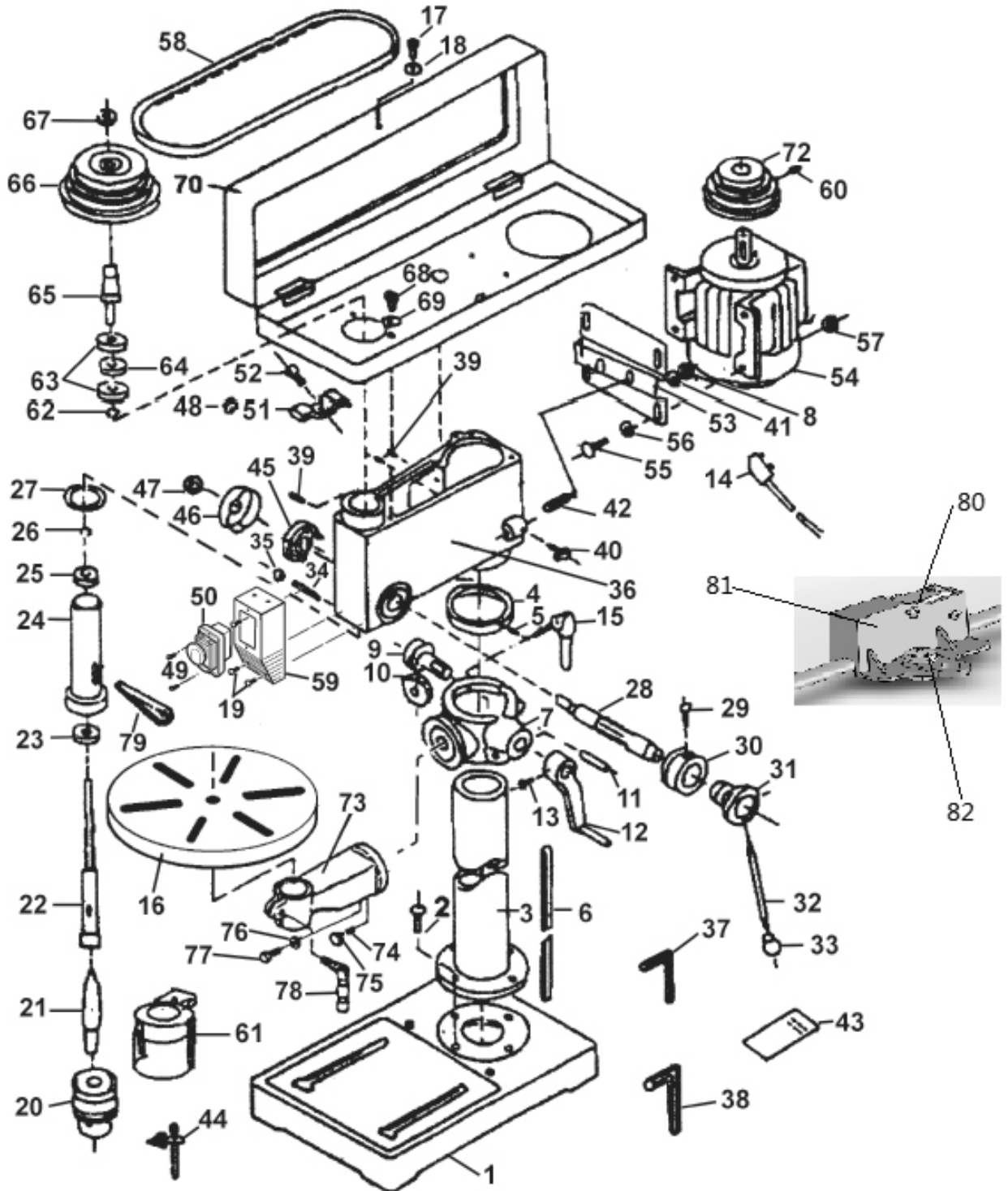

Parts Information:
Pillar Drill Bench 5-Speed 745mm Height
370W/230V
Model No: GDM50B.V2



NOTE: It is our policy to continually improve products and as such we reserve the right to alter data, specifications and component parts without prior notice.

IMPORTANT: No liability is accepted for incorrect use of product.

WARRANTY: Guarantee is 12 months from purchase date, proof of which will be required for any claim.

Sealey Group, Kempson Way, Suffolk Business Park, Bury St Edmunds, Suffolk. IP32 7AR



01284 757500



01284 703534



sales@sealey.co.uk



www.sealey.co.uk



Parts Information:
**Pillar Drill Bench 5-Speed 745mm Height
 370W/230V
 Model No: GDM50B.V2**

Item	Part No.	Description
1	GDM92B/01	BASE
2	GDM92B/02	BOLT M10x25
3	GDM50BX/003	COLUMN
4	GDM92B/04	RACK RING
5	GDM92B/05	HEADLESS SET SCREW
6	GDM92B/06	RACK
7	GDM92B/07	TABLE ARM BRACKET
8	SN8.S	STEEL NUT M8 ZINC DIN934 (SINGLE)
9	GDM92B/09	WORM GEAR
10	GDM92B/10	GEAR
11	GDM92B/11	SHAFT
12	GDM92B/12	HANDLE
13	GDM92B/13	SET BOLT
14	GDM92B/14	PLUG
15	GDM92B/15	CLAMP BOLT
16	GDM92B/16	TABLE
17	GDM50BX/017	PHILLIPS BOLT M5X12
18	FWM5.S	FLAT WASHER M5 SINGLE
19	SCB1230.SB	SOCKET CAP BOLT BLACK M12X30
20	GDM92B/20	CHUCK B16 3-16mm
21	GDM92B/21	ARBOR
22	GDM92B/22	SPINDLE
23	B/6204-2RS	BEARING 6204-2RS
24	GDM92B/24	SPINDLE SLEEVE
25	B/6201ZZ	BEARING 6201ZZ
26	GDM92B/26	RETAINING RING
27	GDM92B/27	RUBBER WASHER M40
28	GDM92B/28	FEED SHAFT
29	GDM92B/29	CLAMP BOLT
30	GDM92B/30	SCALE RING
31	GDM92B/31	HANDLE BODY
32	GDM92B/32	HANDLE
33	GDM92B/33	KNOB
34	GDM92B/34	HEADLESS SET SCREW
35	SN8.S	STEEL NUT M8 ZINC DIN934 (SINGLE)
36	GDM92B/36	BODY (SO)
37	GDM92B/37	HEX.KEY
38	GDM92B/38	HEX.KEY
39	GSM812.S	GRUB SCREW M8x12 (SINGLE)
40	GDM92B/40	SLIDE BAR BOLT
41	GDM92B/41	SCREW
42	GDM92B/42	SLIDE BAR
43	GDM50BX/043	INSTRUCTION MANUAL

Item	Part No.	Description
44	GDM92B/44	CHUCK KEY
45	GDM92B/45	SPRING
46	GDM92B/46	SPRING SEAT
47	GDM92B/47	M12 X 1.5 FINE PITCH HALF NUT
48	GDM92B/48	PLASTIC JAM NUT
49	GDM92B/49	SCREW 6 X 1/2" AB PAN SELF TAP SUPADRIVE BZP
50	GDM92B/50	SWITCH (FRONT MOUNT WITH EMERGENCY STOP)
51	GDM92B/51	WIRE CLAMP
52	MSP410.S	MACHINE SCREW PAN HEAD PHILLIPS M4x10mm
53	GDM92B/53	MOTOR BASE
54	GDM92B/54	MOTOR (370W MAX NO LOAD 550W MAX LOAD)
55	SS830.S	HEX HEAD SET SCREW M8x30mm SINGLE
56	GDM92B/56	WASHER
57	SN8.S	STEEL NUT M8 ZINC DIN934 (SINGLE)
58	V/M30	V-BELT (ID-765) M30 (
59	GDM92B/50A	SWITCH HOUSING
60	GDM92B/60	HEADLESS SET SCREW
61	DPG99	DRILL PRESS GUARD 60mm
62	GDM92B/62	RETAINING RING
63	B/6203ZZ	BEARING 6203ZZ
64	GDM92B/64	COLLAR
65	GDM92B/65	DRIVE SLEEVE
66	GDM50BX/066	SPINDLE PULLEY
67	GDM92B/67	PULLEY HALF NUT
68	MSP612.S	MACHINE SCREW PAN HEAD PHILLIPS M6x12mm
69	FWM6.S	FLAT WASHER M6 SINGLE
70	GDM92B/70	PULLEY COVER
72	GDM50BX/072	MOTOR PULLEY
73	GDM92B/07A	TABLE ARM
74	GDM92B/80	PIN
75	SN6.S	STEEL NUT M6 ZINC DIN934 (SINGLE)
76	FWM10.S	FLAT WASHER M10 SINGLE
77	SCB1230.SB	SOCKET CAP BOLT BLACK M12X30
78	GDM92B/15A	TABLE BOLT
79	GDM92B/79	WEDGE
80	GDM92B.81	MICRO SWITCH
81	GDM92B.82	MICRO SWITCH HOLDER
82	GDM92B.83	PHILLIPS BOLT M6X12
--	DPG99	DRILL PRESS GUARD 60MM (NOT SHOWN)

NOTE: It is our policy to continually improve products and as such we reserve the right to alter data, specifications and component parts without prior notice.

IMPORTANT: No liability is accepted for incorrect use of product.

WARRANTY: Guarantee is 12 months from purchase date, proof of which will be required for any claim.

Sealey Group, Kempson Way, Suffolk Business Park, Bury St Edmunds, Suffolk. IP32 7AR



01284 757500



01284 703534



sales@sealey.co.uk



www.sealey.co.uk