



600W, 900W, 1000W, 2000W ANGLE GRINDERS

MODEL NO: **SG101.V2, SG115.V2, SG125, SG2303.V2**

Thank you for purchasing a Sealey product. Manufactured to a high standard, this product will, if used according to these instructions, and properly maintained, give you years of trouble free performance.

IMPORTANT: PLEASE READ THESE INSTRUCTIONS CAREFULLY. NOTE THE SAFE OPERATIONAL REQUIREMENTS, WARNINGS & CAUTIONS. USE THE PRODUCT CORRECTLY AND WITH CARE FOR THE PURPOSE FOR WHICH IT IS INTENDED. FAILURE TO DO SO MAY CAUSE DAMAGE AND/OR PERSONAL INJURY AND WILL INVALIDATE THE WARRANTY. KEEP THESE INSTRUCTIONS SAFE FOR FUTURE USE.



Refer to instructions



Wear eye protection



Wear protective gloves



Wear safety footwear



Wear protective clothing



Wear ear protection



Wear a mask



Wear respiratory protection (fumes)

1. SAFETY

1.1. ELECTRICAL SAFETY

- WARNING!** It is the responsibility of the owner and the operator to read, understand and comply with the following:
You must check all electrical products, before use, to ensure that they are safe. You must inspect power cables, plugs, sockets and any other connectors for wear or damage. You must ensure that the risk of electric shock is minimised by the installation of appropriate safety devices. A Residual Current Circuit Breaker (RCCB) should be incorporated in the main distribution board. We also recommend that a Residual Current Device (RCD) is used. It is particularly important to use an RCD with portable products that are plugged into a supply which is not protected by an RCCB. If in any doubt consult a qualified electrician. You may obtain a Residual Current Device by contacting your Sealey dealer. You must also read and understand the following instructions concerning electrical safety.
- ✓ The Electricity at Work Act 1989 requires that all portable electrical appliances, if used on business premises, are tested by a qualified electrician, using a Portable Appliance Tester (PAT), at least once a year.
- ✓ The Health & Safety at Work Act 1974 makes owners of electrical appliances responsible for the safe condition of those appliances and the safety of the appliance operators. If in any doubt about electrical safety, contact a qualified electrician.
- ✓ Ensure that the insulation on all cables and on the appliance is safe before connecting it to the power supply.
- ✓ Ensure that cables are always protected against short circuit and overload.
- ✓ Regularly inspect power supply cables and plugs for wear or damage and check all connections to ensure that none is loose.
- ✓ Ensure that the voltage marked on the appliance matches the power supply to be used and that the plug is fitted with the correct fuse - see fuse rating.
- ✗ **DO NOT** pull or carry the appliance by the power cable.
- ✗ **DO NOT** pull the plug from the socket by the cable.
- ✗ **DO NOT** use worn or damaged cables, plugs or connectors. Immediately have any faulty item repaired or replaced by a qualified electrician. When a BS 1363/A UK 3 pin plug is damaged, cut the cable just above the plug and dispose of the plug safely.
Fit a new plug according to the following instructions (UK only).
 - a) Connect the GREEN/YELLOW earth wire to the earth terminal 'E'.
 - b) Connect the BROWN live wire to the live terminal 'L'.
 - c) Connect the BLUE neutral wire to the neutral terminal 'N'.
 - d) After wiring, check that there are no bare wires, that all wires have been correctly connected, that the cable outer insulation extends beyond the cable restraint and that the restraint is tight. Double insulated products, which are always marked with this symbol , are fitted with live (brown) and neutral (blue) wires only. To rewire, connect the wires as indicated above - **DO NOT** connect either wire to the earth terminal.Products which require more than 13 amps are supplied without a plug. In this case you must contact a qualified electrician to ensure that a suitably rated supply is available. We recommend that you discuss the installation of an industrial round pin plug and socket with your electrician.
- ✓ If an extension reel is used it should be fully unwound before connection. A reel with an RCD fitted is preferred since any appliance plugged into it will be protected. The cable core section is important and should be at least 1.5mm², but to be absolutely sure that the capacity of the reel is suitable for this product and for others which may be used in the other output sockets, we recommend the use of 2.5mm² section cable.
- WARNING!** The warnings, cautions and instructions in this manual cannot cover all possible conditions and situations that may occur. It must be understood by the operator that common sense and caution are factors which cannot be built into this product, but must be applied by the operator.

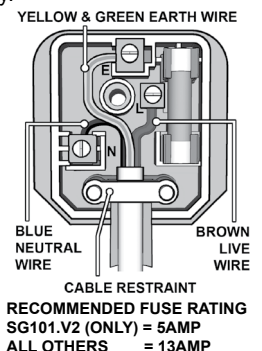

1.2. GENERAL SAFETY

- Disconnect the grinder from the mains power before changing accessories, servicing or performing any maintenance. Maintain grinder and discs in good condition. Check moving parts and alignment. If necessary use an authorised service agent. Replace or repair damaged parts. Use recommended parts only. Unauthorised parts may be dangerous and will invalidate the warranty.
- ✓ Keep the grinder clean for best and safest performance.
 - WARNING!** Always work with the grinder safety guard in place.
 - ✓ Wear approved safety goggles, ear defenders, safety gloves, appropriate mask if grinder generates dust/fumes.

- ✓ Remove ill fitting clothing. Remove ties, watches, rings and other loose jewellery and contain long hair.
- ✓ Use grinder in a suitable work area. Keep area clean, tidy and free from unrelated materials and ensure that there is adequate lighting.
- ✓ Maintain correct balance and footing. DO NOT over-reach and ensure that the floor is not slippery. Wear non-slip shoes.
- ✓ Use only approved grinding discs and only use the normal grinding surface. Never use the side or upper surface of disc for cutting.
- ✓ The grinding disc may only be changed by a person holding a grinding wheel certificate.
- ✓ Check grinding disc to ensure it is not split, cracked or damaged in anyway. If in doubt DO NOT use the disc.
- ✓ Grinding discs must be securely attached before use, but not overtightened.

WARNING! – Risk of Hand Arm Vibration Injury.

This tool may cause Hand Arm Vibration Syndrome if its use is not managed adequately.
 This tool is subject to the vibration testing section of the Machinery Directive 2006/42/EC.
 This tool is to be operated in accordance with these instructions.

Measured vibration emission value (a): 10.232 m/s ²	Model No SG101.V2
Uncertainty value (k): 1.5 m/s ²	
Measured vibration emission value (a): 8.42 m/s ²	Model No SG115.V2
Uncertainty value (k): 1.5 m/s ²	
Measured vibration emission value (a): 2.989 m/s ²	Model No SG125
Uncertainty value (k): 1.5 m/s ²	
Measured vibration emission value (a): 5.634 m/s ²	Model No SG2303.V2
Uncertainty value (k): 1.5 m/s ²	

Please note that the application of the tool to a sole specialist task may produce a different average vibration emission. We recommend that a specific evaluation of the vibration emission is conducted prior to commencing with a specialist task.

A health and safety assessment by the user (or employer) will need to be carried out to determine the suitable duration of use for each tool.
 NB: Stated Vibration Emission values are type-test values and are intended to be typical.
 Whilst in use, the actual value will vary considerably from and depend on many factors.
 Such factors include; the operator, the task and the inserted tool or consumable.
 NB: ensure that the length of leader hoses is sufficient to allow unrestricted use, as this also helps to reduce vibration.

The state of maintenance of the tool itself is also an important factor, a poorly maintained tool will also increase the risk of Hand Arm Vibration Syndrome.

Health surveillance.
 We recommend a program of health surveillance to detect early symptoms of vibration injury so that management procedures can be modified accordingly.

Personal protective equipment.
 We are not aware of any personal protective equipment (PPE) that provides protection against vibration injury that may result from the uncontrolled use of this tool. We recommend a sufficient supply of clothing (including gloves) to enable the operator to remain warm and dry and maintain good blood circulation in fingers etc. Please note that the most effective protection is prevention, please refer to the Correct Use and Maintenance section in these instructions. Guidance relating to the management of hand arm vibration can be found on the HSC website www.hse.gov.uk - Hand-Arm Vibration at Work.

2. INTRODUCTION

- MODEL No SG101.V2** Suitable for a variety of trade applications. Features heavy-duty alloy bevel gear head with composite body casing and spindle lock for fast loading/unloading of discs. 600W Heavy-duty motor develops powerful 11000rpm (no load speed). Supplied with side handle, guard and spanner. Fitted 3mtr power cable with BS approved non rewirable plug. Grinding disc not included, order Model No. PTC/100G.
- MODEL No SG115.V2** Suitable for a variety of trade applications. Features heavy-duty alloy bevel gear head with composite body casing and spindle lock for fast loading/unloading of discs. 900W Heavy-duty motor develops powerful 11000rpm (no load speed). Supplied with side handle, guard and spanner. Fitted 3mtr power cable with BS approved non rewirable plug. Grinding disc not included, order Model No. PTC/115G.
- MODEL No SG125** Suitable for a variety of trade applications. Features heavy-duty alloy bevel gear head with composite body casing and spindle lock for fast loading/unloading of discs. 1000W Heavy-duty motor develops powerful 11000rpm (no load speed). Supplied with side handle, guard and spanner. Fitted 3mtr power cable with BS approved non rewirable plug. Grinding disc not included, order Model No. PTC/125G.
- MODEL No SG2303.V2** Heavy-duty alloy bevel gear head with composite body housing a powerful 2000W motor. Fitted with soft start to reduce mains draw when switched on. Spindle lock device for fast loading/unloading of discs. Supplied with side handle, guard and spanner. Fitted 3mtr power cable with BS approved non rewirable plug. Grinding disc not included, order Model No. PTC/230G.

3. SPECIFICATION

Model	SG101.V2
Power input	600W
No-load speed	11000rpm
Spindle Size	M10
Grinding/cutting disc max. dia.	100mm
Sound Pressure/power level	85/96dB(A)
Weight	1.8kg
Model	SG115.V2
Power input	900W
No-load speed	11000rpm
Spindle Size	M14
Grinding/cutting disc max. dia.	115mm
Sound Pressure/power level	86/97dB(A)
Weight	2.2kg

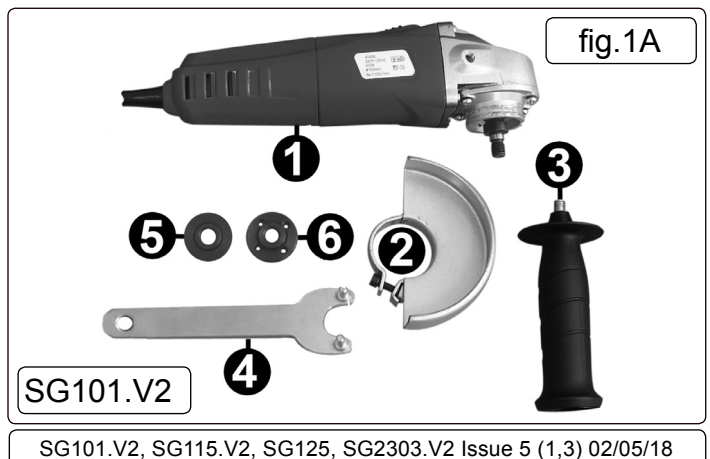

ModelSG125
 Power input 1000W
 No-load speed 11000rpm
 Spindle SizeM14
 Grinding/cutting disc max. dia. 125mm
 Sound Pressure/power level 90/101dB(A)
 Weight2.4kg

ModelSG2303.V2
 Power input 2000W
 No-load speed 6000rpm
 Spindle SizeM14
 Grinding/cutting disc max. dia.230mm
 Sound Pressure/power level 94/105dB(A)
 Weight1.8kg

Item	Description
1	Main Unit
2	Safety Guard c/w fixing
3	Handle
4	Pin Wrench
5	Clamping Flange
6	Flange Nut

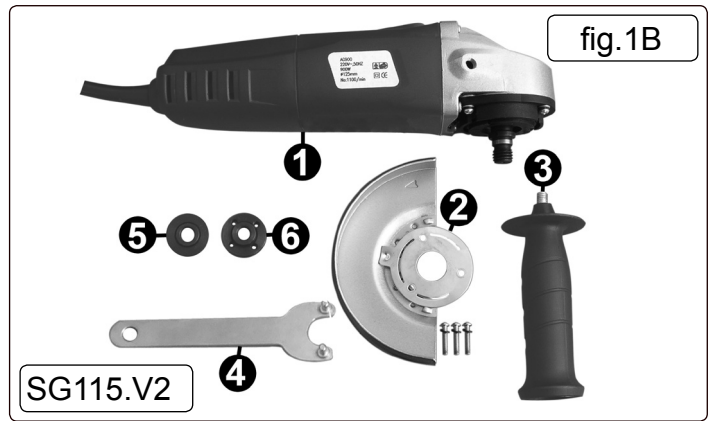

4. ASSEMBLY

❑ **WARNING!** Ensure that the grinder is unplugged from the power supply before assembly.

4.1. Fitting the Guard Assembly. (SG101.V2)

4.1.1. The guard may be orientated at any angle to suit the grinding task required and should be positioned to allow maximum working performance whilst providing maximum personal protection for the operator.

4.1.2. Loosen locking screw and turn the guard to the required position. Lock the guard in place by re-tightening the locking screw.

4.2. Fitting the Guard Assembly. (SG115.V2, SG125)

4.2.1. The guard may be orientated at any angle to suit the grinding task required and should be positioned to allow maximum working performance whilst providing maximum personal protection for the operator.

4.2.2. Take the guard and place it around the spindle as in fig.4, place the securing plate (fig.4B) around the spindle and line up the holes in the plate with the holes in the main unit as in fig.4 and secure with screws (fig.4A).

4.3. Fitting the Guard Assembly. (SG2303.V2)

4.3.1. The guard may be orientated at any angle to suit the grinding task required and should be positioned to allow maximum working performance whilst providing maximum personal protection for the operator.

4.3.2. Take the guard (fig.1 item 2) and unlock the clamp. On the inside of the guard clamping collar is a small pip (indicated by arrow 'A' in fig.5) which must be aligned with a notch in the housing (also indicated by arrow 'A'). Orientate the guard as shown in fig.5 and place it over the central spindle and onto the housing. Leaving the clamp open, rotate the guard on the housing until it is over the main body of the tool as indicated in fig.3.

4.3.3. Lock the guard in place by pushing the clamp lever towards the centre spindle as shown in fig.3.

4.4. Attaching a Grinding/Cutting Disc.

(Discs should only be fitted by a person holding a grinding wheel certificate).

4.4.1. Lay the grinder on it's back and place the clamping flange onto the centre spindle with the raised ring facing upwards (see fig.2 item 5). Rotate the clamping flange on the spindle until the flats on its back face drop into alignment with the flats on the spindle. When the clamping flange is in the correct position it can no longer be rotated on the spindle.

4.4.2. Place the grinding (or cutting) disc over the spindle and onto the clamping flange. fig8A , fig8B, fig8C section 6. CONSUMABLES shows the correct orientation of the retaining flange nut for the different types of disc.

- 4.4.3. When using a grinding disc with a depressed centre portion as in fig.A, Screw the disc retaining flange nut onto the spindle with the raised ring facing downwards.
- 4.4.4. When using flat cutting discs as in fig.C and cutting discs with a depressed centre portion as in fig.B, screw the disc retaining flange nut onto the spindle with the raised ring facing upwards.
- 4.4.5. Stop the spindle from turning by pushing in and holding the disc stop button (see fig.2.7).
- 4.4.6. Lock the grinding disc into place by tightening the disc retaining flange nut with the pin wrench (fig.2 item 4).
- 4.4.7. When complete, release the locking button and check that it has sprung back to its initial position.
- 4.5. **Fitting the Hand Grip.**
Always use the hand grip for better control and improved safety. Fit the hand grip (fig.1.3) by screwing it into the appropriate left, right or top position on the grinder head as indicated in fig.2.

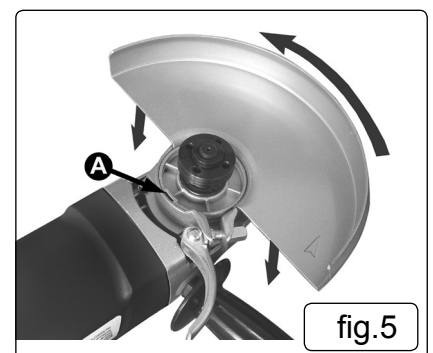
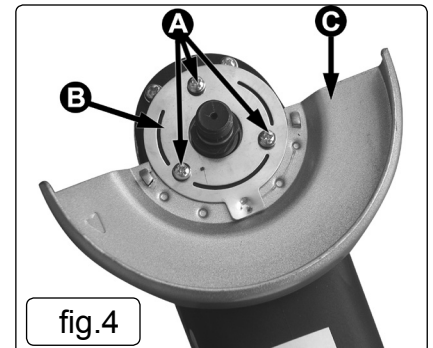
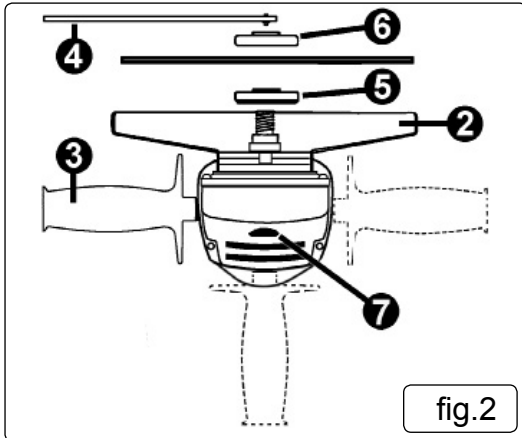

5. OPERATION

- WARNING!** Ensure grinder is unplugged from the mains power supply before changing accessories.
- 5.1. **PREPARATION**
- 5.1.1. Attach grinding/cutting disc according to section 5.4. and position the handle grip conveniently for the task.
- 5.1.2. Ensure the disc safety guard is correctly positioned.
- 5.1.3. Plug grinder into the mains power supply.
- WARNING!** When the grinder first starts it will kick to the right. You must ensure, therefore, that the tool is securely gripped in both hands. Especially important is the position you choose for the side handle in order to maintain stability.
 - WARNING!** Before use, ensure that you are wearing approved safety goggles, ear defenders, appropriate dust mask if dust will be generated and safety gloves, and that all other safety instructions in Section 1 are followed carefully.
- 5.2. **ON/OFF Switch (SG101.V2, SG115.V2)**
- 5.2.1. The ON/OFF (I/O) switch (fig.6) is designed to avoid accidental starting.
- 5.2.2. Once plugged into the power supply start the grinder by sliding the switch forward and pressing down (I).
- 5.2.3. To turn off the machine press the switch at the rear and it will spring back to the 'OFF' position (O).
- 5.3. **ON/OFF Switch (SG125, SG2303.V2)**
- 5.3.1. Once plugged into the mains power supply the grinder is started by a two stage switching operation. Place your fingers over the switch and using your index finger unlock the trigger by pushing the lock lever forwards and then squeeze the trigger into the 'ON' position. (See fig.7)
- 5.3.2. To stop the grinder release the trigger.
- 5.3.3. When the trigger is released and returns to the 'OFF' position it is automatically locked to prevent inadvertent starting.
- 5.3.4. The trigger can be locked in the 'ON' position for continuous running. To do this release the lock and squeeze the trigger as previously described. With the trigger fully depressed push the lock lever one stage further forward. Whilst maintaining pressure on the lock lever release the trigger which will now stay in the 'ON' position.
- 5.3.5. To stop the grinder squeeze the trigger to unlock it and release the trigger.
- 5.3.6. If the power is cut to the grinder whilst the switch is locked 'ON' always release the trigger and unplug the grinder. **DO NOT** reconnect the grinder until you are sure that the power has been restored.
- 5.4. **GRINDING**
- 5.4.1. The key to effective operating is controlling the pressure and surface contact between the disc and the work piece.
- WARNING! DO NOT** switch the grinder on whilst the disc is in contact with the work piece. Bring the rotating disc to the work piece.
- 5.4.2. Allow the disc to reach full speed before starting to grind.
- 5.4.3. Grind flat surfaces at an angle of between 10° to 20° to the work piece. Too great an angle will cause a concentration of pressure in one small area resulting in gouging or burning of the surface.
- 5.4.4. When grinding is complete allow the work piece to cool. **DO NOT** touch the hot surface.
- 5.4.5. Unplug the grinder from the mains power supply, clean and store in a safe, dry, childproof area.

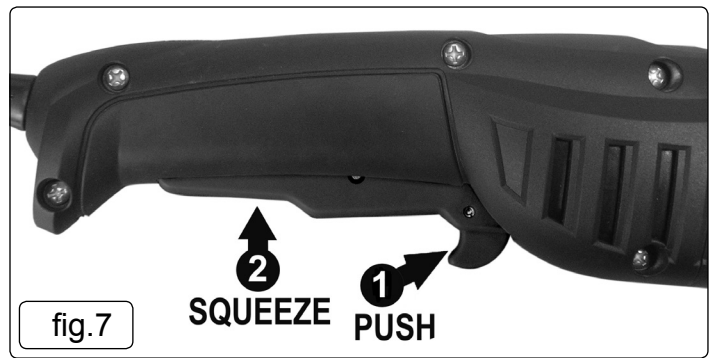
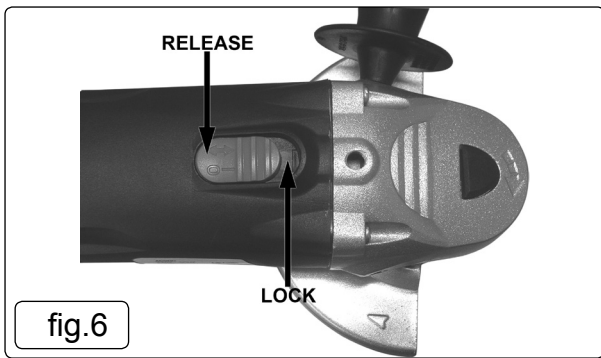

6. CONSUMABLES

- ❑ **WARNING! DO NOT USE DISCS THAT ARE DAMAGED, OR SUSPECTED TO BE DAMAGED.**
- 6.1. Before using a grinding/cutting disc ensure that there are no fissures or cracks. Once mounted on the grinder, test the disc before use by facing the grinder in a safe direction (point away from yourself, others and vulnerable items) and run for a short time.
 - ▲ **DANGER!** Use of damaged discs is dangerous and may cause personal injury.
 - 6.2. Grinding and cutting discs used in association with this machine shall be of an adequate speed rating and be suitable for the job in hand. The discs shall be made in accordance with British Standard 4481:Part 1 1989. Only persons holding a grinding wheel certificate are authorised to change grinding discs. Ensure that the speed rating on the disc is equal to, or higher than, that of the grinder.

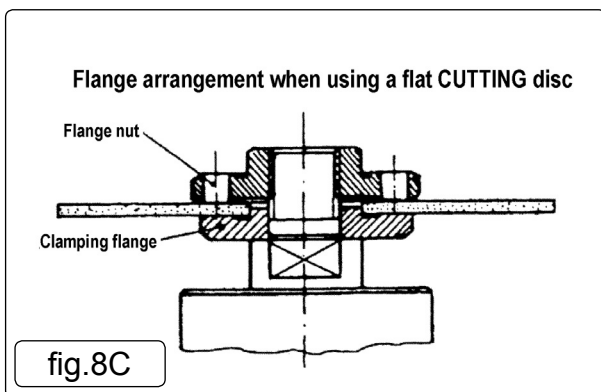
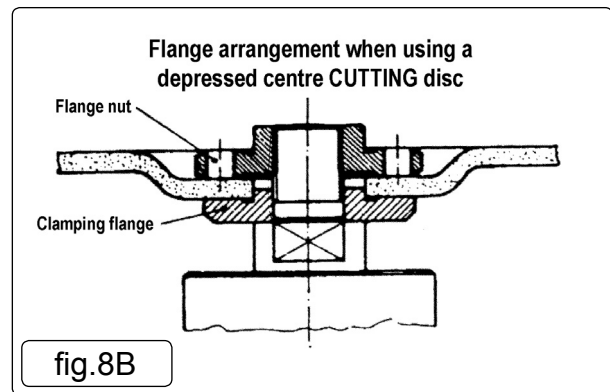
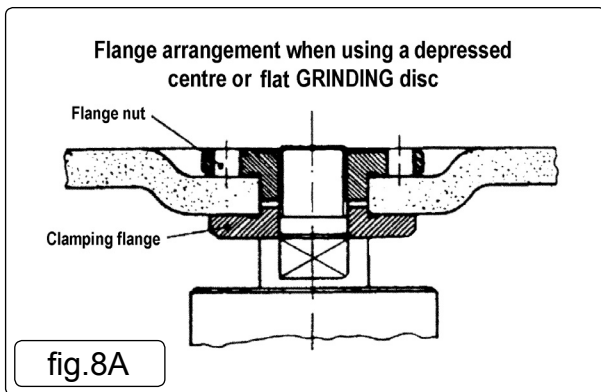

7. MAINTENANCE

- ❑ **WARNING!** Ensure that the grinder is disconnected from the mains power supply before attempting any maintenance.
- 7.1. **Cleaning**
 - 7.1.1. Keep the grinder ventilation slots clean and free from obstructions. If available, blow compressed air into the vents to clear any internal dust (safety goggles must be worn when undertaking this process). Keep the outer case of the grinder clean and free from grease.
 - ✱ **DO NOT** wash with water or use solvents or abrasives.
 - 7.2. **Changing the motor brushes (SG101.V2, SG115.V2)**
 - 7.2.1. Remove the screw at the rear of the grinder then pull the rear body casing away.
 - 7.2.2. Release the brush assembly cap as in fig.9.
 - 7.2.3. Remove the brush assembly and replace.
 - 7.2.4. Refitting is a reversal of the above procedure.
 - 7.2.5. Repeat for the second brush on the other side of the grinder.
 - 7.3. **Changing the motor brushes (SG125, SG2303.V2)**
 - 7.3.1. Remove the screw from the side panel half way up the grinder, then remove panel
 - 7.3.2. Release the tension spring from the carbon brush and slide it out of the brush holder. (fig.10)
 - 7.3.3. Replace the motor brush.
 - 7.3.4. Refitting is a reversal of the above procedure.
 - 7.3.5. Repeat for the second brush on the other side of the grinder.

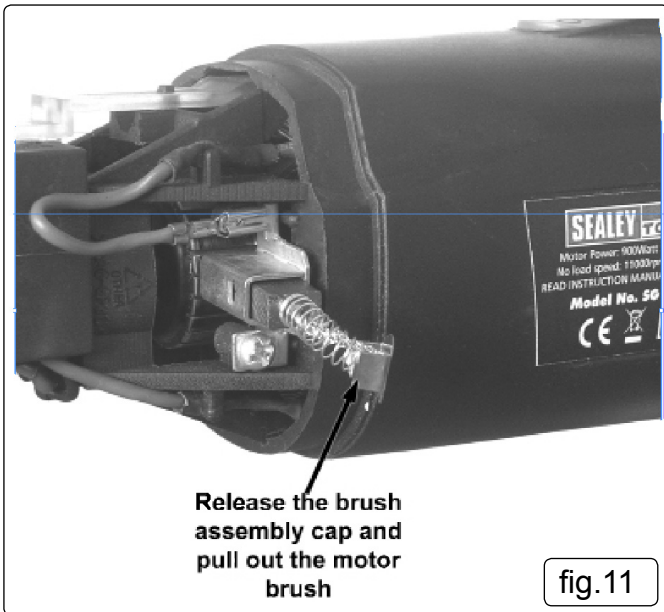

fig.11

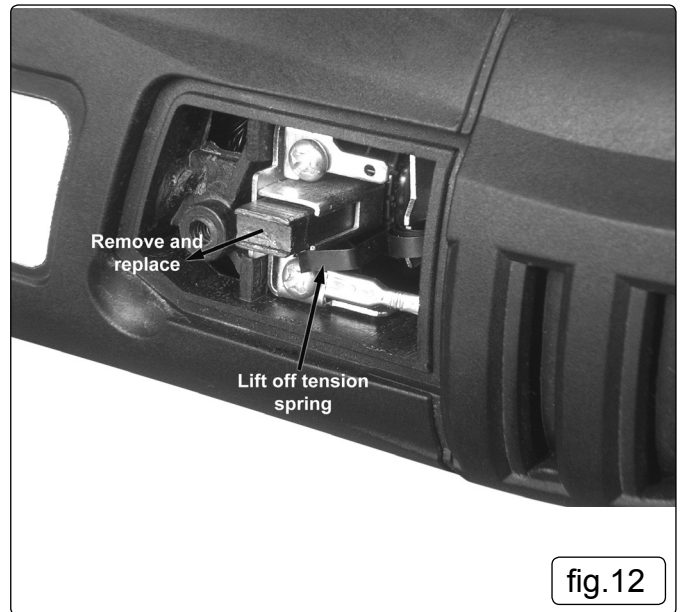

fig.12

Parts support is available for this product. To obtain parts, please log on to www.sealey.co.uk, email sales@sealey.co.uk or telephone 01284 757500

ENVIRONMENT PROTECTION



Recycle unwanted materials instead of disposing of them as waste. All tools, accessories and packaging should be sorted, taken to a recycling centre and disposed of in a manner which is compatible with the environment. When the product becomes completely unserviceable and requires disposal, drain any fluids (if applicable) into approved containers and dispose of the product and fluids according to local regulations.

WEEE REGULATIONS



Dispose of this product at the end of its working life in compliance with the EU Directive on Waste Electrical and Electronic Equipment (WEEE). When the product is no longer required, it must be disposed of in an environmentally protective way. Contact your local solid waste authority for recycling information.

Note: It is our policy to continually improve products and as such we reserve the right to alter data, specifications and component parts without prior notice.

Important: No Liability is accepted for incorrect use of this product.

Warranty: Guarantee is 12 months from purchase date, proof of which is required for any claim.

Sealey Group, Kempson Way, Suffolk Business Park, Bury St Edmunds, Suffolk. IP32 7AR



01284 757500



01284 703534



sales@sealey.co.uk



www.sealey.co.uk