



INSTRUCTIONS FOR

## SUBMERSIBLE WATER PUMPS

MODEL NO'S:

**WPC100.V2 | WPC100A.V2 | WPC150.V2 | WPC150A.V2 | WPC235.V2 | WPC235A.V2 | WPC250 | WPC250A**

Thank you for purchasing a Sealey product. Manufactured to a high standard, this product will, if used according to these instructions, and properly maintained, give you years of trouble free performance.

**IMPORTANT:** PLEASE READ THESE INSTRUCTIONS CAREFULLY. NOTE THE SAFE OPERATIONAL REQUIREMENTS, WARNINGS & CAUTIONS. USE THE PRODUCT CORRECTLY AND WITH CARE FOR THE PURPOSE FOR WHICH IT IS INTENDED. FAILURE TO DO SO MAY CAUSE DAMAGE AND/OR PERSONAL INJURY AND WILL INVALIDATE THE WARRANTY. KEEP THESE INSTRUCTIONS SAFE FOR FUTURE USE.



Refer to  
instruction  
manual

### 1. SAFETY

#### 1.1. ELECTRICAL SAFETY

- WARNING!** It is the user's responsibility to check the following:  
Check all electrical equipment and appliances to ensure that they are safe before using. Inspect power supply leads, plugs and all electrical connections for wear and damage. Sealey recommend that an RCD (Residual Current Device) is used with all electrical products. You may obtain an RCD by contacting your local Sealey dealer.  
If the pump is used in the course of business duties, it must be maintained in a safe condition and routinely PAT (Portable Appliance Test) tested.  
Electrical safety information, it is important that the following information is read and understood.
- 1.1.1. Ensure that the insulation on all cables and on the appliance is safe before connecting it to the power supply.
- 1.1.2. Regularly inspect power supply cables and plugs for wear or damage and check all connections to ensure that they are secure.
- 1.1.3. **Important:** Ensure that the voltage rating on the appliance suits the power supply to be used and that the plug is fitted with the correct fuse - see fuse rating in these instructions.
  - \* **DO NOT** pull or carry the appliance by the power cable.
  - \* **DO NOT** pull the plug from the socket by the cable.
  - \* **DO NOT** use worn or damaged cables, plugs or connectors. Ensure that any faulty item is repaired or replaced immediately by a qualified electrician.
- 1.1.4. This product is fitted with a BS1363/A 13 Amp 3 pin plug.  
If the cable or plug is damaged during use, switch the electricity supply and remove from use.  
Ensure that repairs are carried out by a qualified electrician.  
Replace a damaged plug with a BS1363/A 13 Amp 3 pin plug. If in doubt contact a qualified electrician.
  - a) Connect the GREEN/YELLOW earth wire to the earth terminal 'E'.
  - b) Connect the BROWN live wire to the live terminal 'L'.
  - c) Connect the BLUE neutral wire to the neutral terminal 'N'.Ensure that the cable outer sheath extends inside the cable restraint and that the restraint is tight.  
Sealey recommend that repairs are carried out by a qualified electrician.
- 1.1.5. Only allow the minimal amount of pump cable to enter water or wet areas. The electrical cable is designed for use in water and must not be substituted. If damaged contact a qualified electrician.
- 1.1.6. Extension cable use. Only use a cable designed for use with water equipment. Contact your stockist or a qualified electrician for advice. Ensure water is kept clear of electrical mains power supply. **DO NOT** touch switch or plug with wet hands.

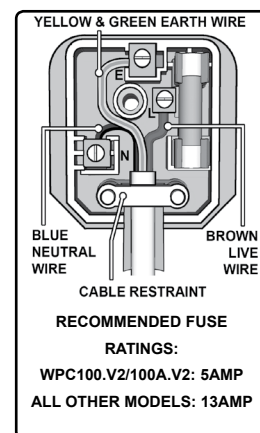

#### 1.2. GENERAL SAFETY

- WARNING!** Pump must be used in accordance with Health & Safety, government, local authority, and water authority rules and regulations.
- ✓ Familiarise yourself with application and limitations, as well as the specific potential hazards peculiar to the pump.
- WARNING!** Disconnect the pump from the mains power before changing accessories, servicing or performing any maintenance.
- ✓ Maintain the pump in good condition (use an authorised service agent). Keep the pump clean.
- ✓ Replace or repair damaged parts. *Use genuine parts only. Unauthorised parts may be dangerous and will invalidate the warranty.*
- ✓ Only use for pumping clean cold or warm water (**NOT** exceeding 35°C).
- ✓ If pump is used to pump water from a well, drain or deep receptacle, take adequate precautions to stop persons and animals falling in.
- ✓ Use the built-in handle to lower or raise the pump. It may be necessary to attach a suitable rope or pulley to the handle.
- ✓ If the bottom of the water container is covered with sludge, sand, gravel or mud etc, suspend the pump or place it on a raised base to operate above the solid matter. Sand and such substances will reduce working life of pump, and invalidate your warranty.
- ✓ In flood situations, user is responsible for ensuring that appropriate back-up procedures, alarms etc are correctly installed in case of pump failure.
- ✓ In swimming pools, fish ponds, etc, ensure location is clear of people and animals, including removal of fish from pond.  
**Note:** this pump is not designed for continuous use in a fish pond or similar water feature or display.
- \* **DO NOT** operate the pump if any parts are damaged or missing as this may cause failure and/or possible personal injury.
- \* **DO NOT** use the pump for any purpose other than that for which it is designed.
- \* **DO NOT** insert hands into the mouth of the pump as this could lead to injury.

- × **DO NOT** use to pump septic tanks or settling pits. **DO NOT** pump any liquids other than water.
  - × **DO NOT** operate the pump out of water. The pump pick up area must be completely submerged during operation.
  - × **DO NOT** exceed the maximum submersible depth (see specifications: Max. Suction Height).
  - × **DO NOT** operate the pump during freezing temperatures. **DO NOT** leave the pump in water that may freeze.
  - × **DO NOT** use in swimming pools if people could come into contact with the water whilst pump is in use.
  - × **DO NOT** use for pumping sea water or inflammable, corrosive, explosive or dangerous liquids.
  - × **DO NOT** carry the pump by its electrical cable, or its outlet pipe. Use the handle only.
  - ✓ When not in use, switch off pump and remove plug from power supply. Rinse pump, drain out any water and store in a frost free, safe location.
  - **WARNING! DO NOT** allow uncontrolled discharge of contaminated water which would pollute the environment.
- NOTE: This appliance is not intended for use by persons (including children) with reduced physical, sensory or mental capabilities or lack of experience and knowledge, unless they have been given supervision or instruction concerning the use of the appliance by a person responsible for their safety. Children should be supervised to ensure that they do not play with the appliance.

## 2. INTRODUCTION

Manufactured from corrosion resistant materials with stainless steel motor case and Noryl base cover. Minimum water depth of just 20mm. Designed for clean water although these pumps will accept small particles up to 5mm. Suitable for the effective drainage of cellars, sinks, cisterns, baths and the general transfer of water. The WPC100A.V2, WPC150A.V2, WPC235A.V2 and WPC250A feature an automatic low water cut-out.

## 3. SPECIFICATION

Model No.	Cut-Out	Outlet OD	Maximum Output	Maximum Head	Motor	Input	Maximum Particle Size	Minimum Water Depth	Maximum Water Depth
WPC100.V2	Manual	32mm	100ltr/min	6.0mtr	250W	230V	5mm	20mm	5mtr
WPC150.V2	Manual	32mm	167ltr/min	8.0mtr	500W	230V	5mm	20mm	7mtr
WPC235.V2	Manual	38mm	208ltr/min	8.5mtr	750W	230V	5mm	20mm	7mtr
WPC250	Manual	38mm	250ltr/min	9.5mtr	900W	230V	5mm	20mm	5mtr
WPC100A.V2	Automatic	32mm	100ltr/min	6.0mtr	250W	230V	5mm	20mm	5mtr
WPC150A.V2	Automatic	32mm	167ltr/min	8.0mtr	500W	230V	5mm	20mm	7mtr
WPC235A.V2	Automatic	38mm	208ltr/min	8.5mtr	750W	230V	5mm	20mm	7mtr
WPC250A	Automatic	38mm	250ltr/min	9.5mtr	900W	230V	5mm	20mm	5mtr

## 4. OPERATION

- **WARNING!** Ensure you read, understand and apply safety instructions.
- 4.1. Fit appropriate discharge pipe to pump outlet and secure with clip. Ensure the diameter of the discharge pipe is the same as or greater than the outlet diameter, as a smaller pipe will adversely effect the pump flow rate.
  - 4.2. Position the pump in the water accordingly, and place the outlet pipe securely in the discharge receptacle or area. It is recommended that the pump is sunk with its discharge outlet facing up, to release any trapped air.
  - 4.3. Connect the pump to the electrical mains supply and switch it on.  
The automatic versions will automatically turn on as the level of water rises (fig.1.A). As the water level lowers, the float will automatically switch the pump off as it reaches the minimum height (fig.1.B). The float may be adjusted by shortening or lengthening the cable. The pump will switch on if the water level is up to or above the maximum length of the float cable. To function correctly the float must move freely. Ensure the float can do so and that the cable is not restricted. Check that the pump and discharge are working correctly.
  - 4.4. The water into which the pump is placed will act as the motor's cooling agent. For this reason the pump must remain submerged at all times. Should the pump have to be used in shallow water, **DO NOT** operate it for more than 10 minutes. Failure to follow this rule will damage the unit and will invalidate the warranty.  
NOTE: See fig.2 to determine minimum clearance required if using pump in a restricted area, i.e. a well, etc.

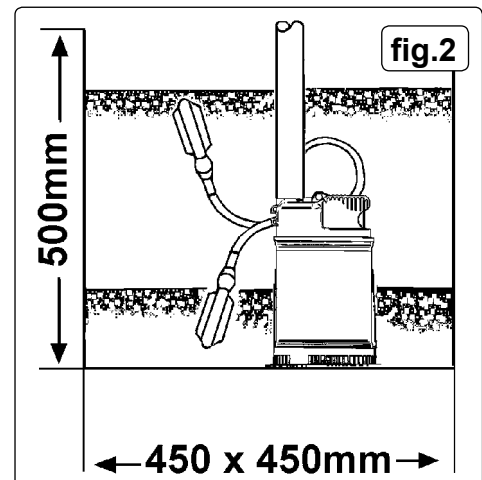
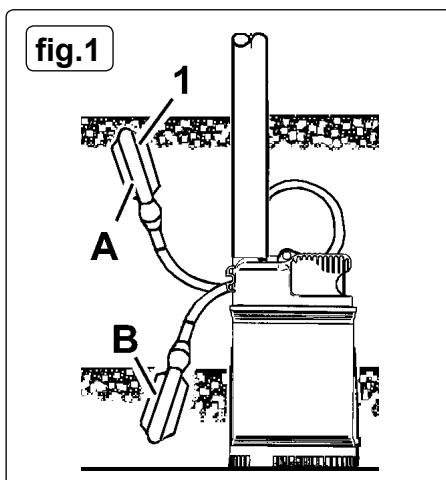

## 5. MAINTENANCE

- **WARNING!** With the exception listed below, all pump, float and electrical cable service maintenance and repair must only be undertaken by an authorised service agent. Failure to observe this rule may be dangerous and will invalidate the warranty.
  - **WARNING!** Ensure the pump is disconnected from the mains power supply before attempting any service or maintenance.
- 4.1. Keep all parts of the pump clean. Rinse, drain and allow to dry before storing the pump.

- 4.2. Regularly check the water inlet on the base of the pump to ensure that there are no blockages. To access the impeller, carefully undo the base hex headed screws and remove the base. Clean the impeller and replace the base ensuring that the O ring is correctly located.
- \* **DO NOT** dismantle any other part of the unit.

## 6. TROUBLESHOOTING

PROBLEM	CAUSE	SOLUTION
a. Motor operates but there is no suction.	<ol style="list-style-type: none"> <li>1. Water level below min suction depth.</li> <li>2. Air bubbles in pump accumulated during submersion, or float is incorrectly positioned so pump does not stop at minimum level and sucks in air.</li> <li>3. Clogged intake filter or discharge pipe.</li> </ol>	<ol style="list-style-type: none"> <li>1. Stop the pump.</li> <li>2. Release air by inclining the pump and re-immersing it in water.</li> <li>3. Remove blockage, and clean the unit.</li> </ol>
b. Reduced water volume for level of water.	<ol style="list-style-type: none"> <li>1. Discharge pipe bent, or pinched.</li> <li>2. Discharge pipe too narrow.</li> <li>3. Pump partially blocked.</li> </ol>	<ol style="list-style-type: none"> <li>1. Straighten pipe.</li> <li>2. Use wider diameter pipe.</li> <li>3. Clean pump.</li> </ol>
c. The pump will not start or suddenly stops during operation.	<ol style="list-style-type: none"> <li>1. No electrical power.</li> <li>2. Float not working.</li> <li>3. Impeller is jammed.</li> </ol>	<ol style="list-style-type: none"> <li>1. Check cable, plug and fuse.</li> <li>2. Contact authorised service agent.</li> <li>3. Clean the pump.</li> </ol>



### ENVIRONMENT PROTECTION

Recycle unwanted materials instead of disposing of them as waste. All tools, accessories and packaging should be sorted, taken to a recycling centre and disposed of in a manner which is compatible with the environment. When the product becomes completely unserviceable and requires disposal, drain any fluids (if applicable) into approved containers and dispose of the product and fluids according to local regulations.



### WEEE REGULATIONS

Dispose of this product at the end of its working life in compliance with the EU Directive on Waste Electrical and Electronic Equipment (WEEE). When the product is no longer required, it must be disposed of in an environmentally protective way. Contact your local solid waste authority for recycling information.

**Note:** It is our policy to continually improve products and as such we reserve the right to alter data, specifications and component parts without prior notice.

**Important:** No Liability is accepted for incorrect use of this product.

**Warranty:** Guarantee is 12 months from purchase date, proof of which is required for any claim.

Sealey Group, Kempson Way, Suffolk Business Park, Bury St Edmunds, Suffolk. IP32 7AR



01284 757500



01284 703534



sales@sealey.co.uk



www.sealey.co.uk



# EC DECLARATION OF CONFORMITY

Description and Function: **Submersible Water Pump 230V 100ltr/min 167ltr/min 208ltr/min 250ltr/min (A = Automatic)**

Model/Type: **WPC100 v2 WPC100A v2 WPC150 v2 WPC150A v2 WPC235 v2 WPC235A v2 WPC250 v1 WPC250A v1**

Manufacturing Date/Serial Number where applicable: .....

2014/30/EU EMC Directive

2014/35/EU Low Voltage Directive

2011/65/EU RoHS Directive

This declaration of conformity is issued under the sole responsibility of the manufacturer:

**Jack Sealey Ltd, Kempson Way, Suffolk Business Park, Bury St Edmunds, Suffolk. IP32 7AR**

Declaration of Conformity in accordance with the above Directive(s).

References to harmonised standard(s)

EN 55014-1:2006+A1+A2 ..... EN 60335-1:2012+A11 .....

EN 55014-2:2015 ..... EN 60335-2-41:2003+A1+A2 .....

EN 61000-3-2:2014 ..... EN 62233:2008.....

EN 61000-3-3:2013 .....  
.....  
.....  
.....

Technical file compiled by: **Jack Sealey Ltd**

**Being the responsible person appointed by the manufacturer.**

Signed *Steve Buckle* .....

Date 4 August 2017 .....

Name Steve Buckle. ....

Position Marketing Director. ....

Place: Bury St Edmunds

**Sealey Group, Kempson Way, Suffolk Business Park, Bury St Edmunds, Suffolk. IP32 7AR**  
📞 01284 757500 📠 01284 703534 ✉ sales@sealey.co.uk 🌐 www.sealey.co.uk



Parts Information:  
Submersible Water Pump 100ltr/min 230V  
Model No: WPC100.V2

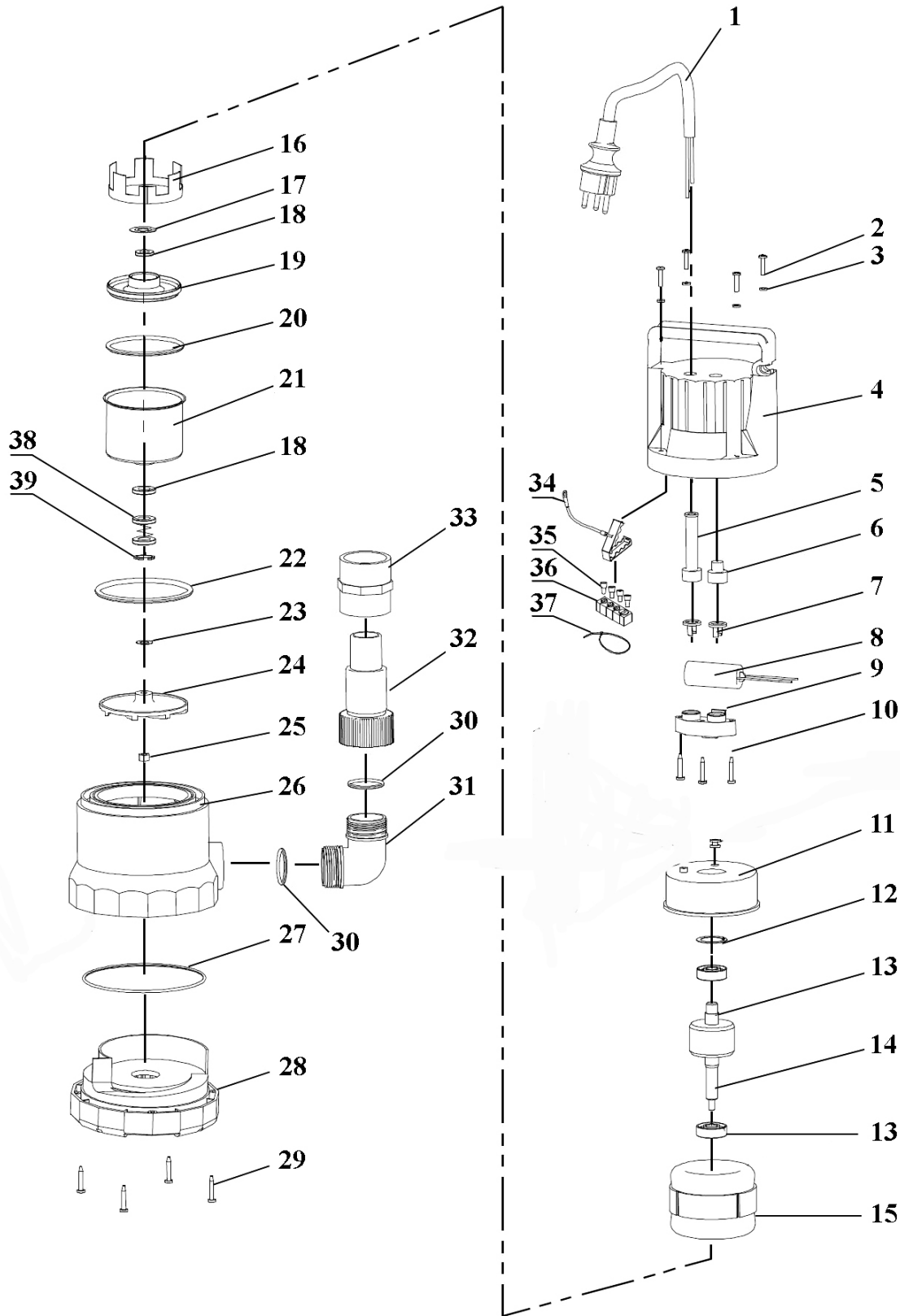

**NOTE:** It is our policy to continually improve products and as such we reserve the right to alter data, specifications and component parts without prior notice.

**IMPORTANT:** No liability is accepted for incorrect use of product.

**WARRANTY:** Guarantee is 12 months from purchase date, proof of which will be required for any claim.

Sealey Group, Kempson Way, Suffolk Business Park, Bury St Edmunds, Suffolk. IP32 7AR



01284 757500



01284 703534



sales@sealey.co.uk



www.sealey.co.uk



Parts Information:  
**Submersible Water Pump 100ltr/min 230V**  
**Model No: WPC100.V2**

1	WP08701001	POWER CABLE
2	WPC100V2.02	SELF-TAPPING SCREW (4.5x30)
3	WP03802031	WASHER
4	WP00302015	REAR PUMP CASING
5	WP05201033	CABLE SHEATH
6	WPC250.06	CABLE PLUG
7	WP05602005	CABLE BUCKLE
8	WPC100V2.08	CAPACITOR 4uF
9	WP05501001	CABLE GRIP
10	WP07802018	SELF-TAPPING SCREW
11	WP02602004	ALUMINUM REAR COVER
12	WP03801001	WAVE WASHER
13	B/6201ZZ	BEARING 6201ZZ
14	WPC100V2.14	ROTOR
15	WPC100V2.15	STATOR
16	WPC250.16	BUSHING
17	WP03802023	WASHER
18	WPC100V2.18	SEAL
19	WP04204001	ALUMINUM BUSHING
20	WPC100V2.20	O-RING
21	WPC100V2.21	FRONT COVER

Item	Part No.	Description
22	WP05101010	O-RING
23	WPC250.23	ADJUSTABLE WASHER
24	WPC100V2.24	IMPELLER
25	WPC100V2.25	NUT
26	WP02901010	MAIN PUMP CASING
27	WPC250.27	O-RING
28	WPC250.28	BASE
29	WP845I	SELF TAPPING SCREW ST4.2x32
30	WPC100V2.30	O-RING
31	WPC250.31	ELBOW
32	WPC100V2.32	OUTLET CONNECTOR
33	WPC250.33	FLEXIBLE CONNECTOR
34	WP04105006	GROUND COVER
35	WP04101001	NYLON SAFETY PRESS LINE CAP
36	WP03203012	RUBBER CLIP
37	WP08501001	CABLE TIE
38	WP06101007	MECHANICAL SEAL
39	WPC100V2.39	BLOCK

**NOTE:** It is our policy to continually improve products and as such we reserve the right to alter data, specifications and component parts without prior notice.

**IMPORTANT:** No liability is accepted for incorrect use of product.

**WARRANTY:** Guarantee is 12 months from purchase date, proof of which will be required for any claim.

**Sealey Group**, Kempson Way, Suffolk Business Park, Bury St Edmunds, Suffolk. IP32 7AR



01284 757500



01284 703534



sales@sealey.co.uk



www.sealey.co.uk



Parts Information:  
Submersible Water Pump Automatic  
100ltr/min 230V  
Model No: WPC100A.V2

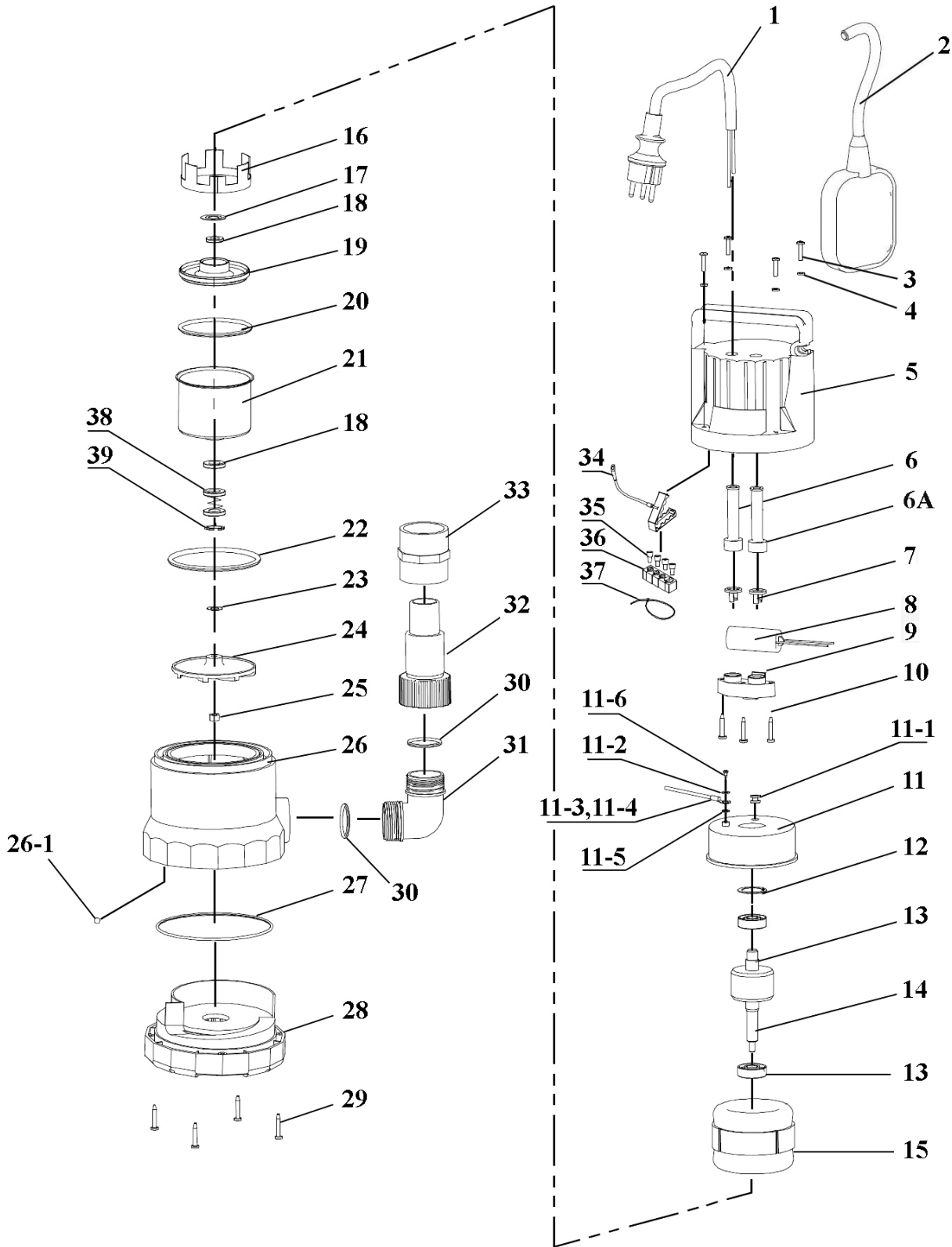

**NOTE:** It is our policy to continually improve products and as such we reserve the right to alter data, specifications and component parts without prior notice.

**IMPORTANT:** No liability is accepted for incorrect use of product.

**WARRANTY:** Guarantee is 12 months from purchase date, proof of which will be required for any claim.

Sealey Group, Kempson Way, Suffolk Business Park, Bury St Edmunds, Suffolk. IP32 7AR



01284 757500



01284 703534



sales@sealey.co.uk



www.sealey.co.uk



Parts Information:  
**Submersible Water Pump Automatic**  
**100ltr/min 230V**  
**Model No: WPC100A.V2**

1	WP08701001	POWER CABLE
2	WPC100AV2.02	FLOAT SWITCH
3	WPC100V2.02	SELF-TAPPING SCREW (4.5x30)
4	WP03802031	WASHER
5	WP00302015	REAR PUMP CASING
--	WPC100V2.04-1	HANDLE COVER (NOT SHOWN)
--	WPD235AV2.05B	REAR PUMP HOUSING (NOT SHOWN)
6	WP05201036	CABLE SHEATH
6A	WP05201033	CABLE SHEATH
7	WP05602008	CABLE BUCKLE
7A	WP05602005	CABLE BUCKLE
8	WPC100V2.08	CAPACITOR 4uF
9	WP05501001	CABLE GRIP
10	WP07802018	SELF-TAPPING SCREW
11	WP02602004	ALUMINUM REAR COVER
11.1	WP05202003	WIRE SHEATH
11.2	WPC100V2.11-2	WASHER
11.3	WP08601010	WIRE (GREEN/YELLOW)
11.4	WP04102006	PLATE
11.5	WPC100V2.11-5	WASHER
11.6	WP818	SCREW M4X8
12	WP03801001	WAVE WASHER
13	B/6201ZZ	BEARING 6201ZZ
14	WPC100V2.14	ROTOR
15	WPC100V2.15	STATOR
16	WPC250.16	BUSHING
17	WP03802023	WASHER

Item	Part No.	Description
18	WPC100V2.18	SEAL
19	WP04204001	ALUMINUM BUSHING
20	WPC100V2.20	O-RING
21	WPC100V2.21	FRONT COVER
22	WP05101010	O-RING
23	WPC250.23	ADJUSTABLE WASHER
--	WPC250.23-1	ADJUSTABLE WASHER (NOT SHOWN)
24	WPC100V2.24	IMPELLER
25	WPC100V2.25	NUT
26	WP02901010	MAIN PUMP CASING
--	WP3086	STEEL BALL (NOT SHOWN)
27	WPC250.27	O-RING
28	WPC250.28	BASE
29	WP845I	SELF TAPPING SCREW ST4.2x32
30	WPC100V2.30	O-RING
31	WPC250.31	ELBOW
32	WPC100V2.32	OUTLET CONNECTOR
33	WPC250.33	FLEXIBLE CONNECTOR
34	WP04105006	GROUND COVER
35	WP04101001	NYLON SAFETY PRESS LINE CAP
--	WP04101003	NYLON SAFETY PRESS LINE CAP (NOT SHOWN)
36	WPC100V2.36	RUBBER CLIP
37	WP08501001	CABLE TIE
38	WP06101007	MECHANICAL SEAL
39	WPC100V2.39	BLOCK

**NOTE:** It is our policy to continually improve products and as such we reserve the right to alter data, specifications and component parts without prior notice.

**IMPORTANT:** No liability is accepted for incorrect use of product.

**WARRANTY:** Guarantee is 12 months from purchase date, proof of which will be required for any claim.

**Sealey Group**, Kempson Way, Suffolk Business Park, Bury St Edmunds, Suffolk. IP32 7AR



01284 757500



01284 703534



sales@sealey.co.uk



www.sealey.co.uk





Parts Information:  
Submersible Water Pump 167ltr/min 230V  
Model No: WPC150.V2

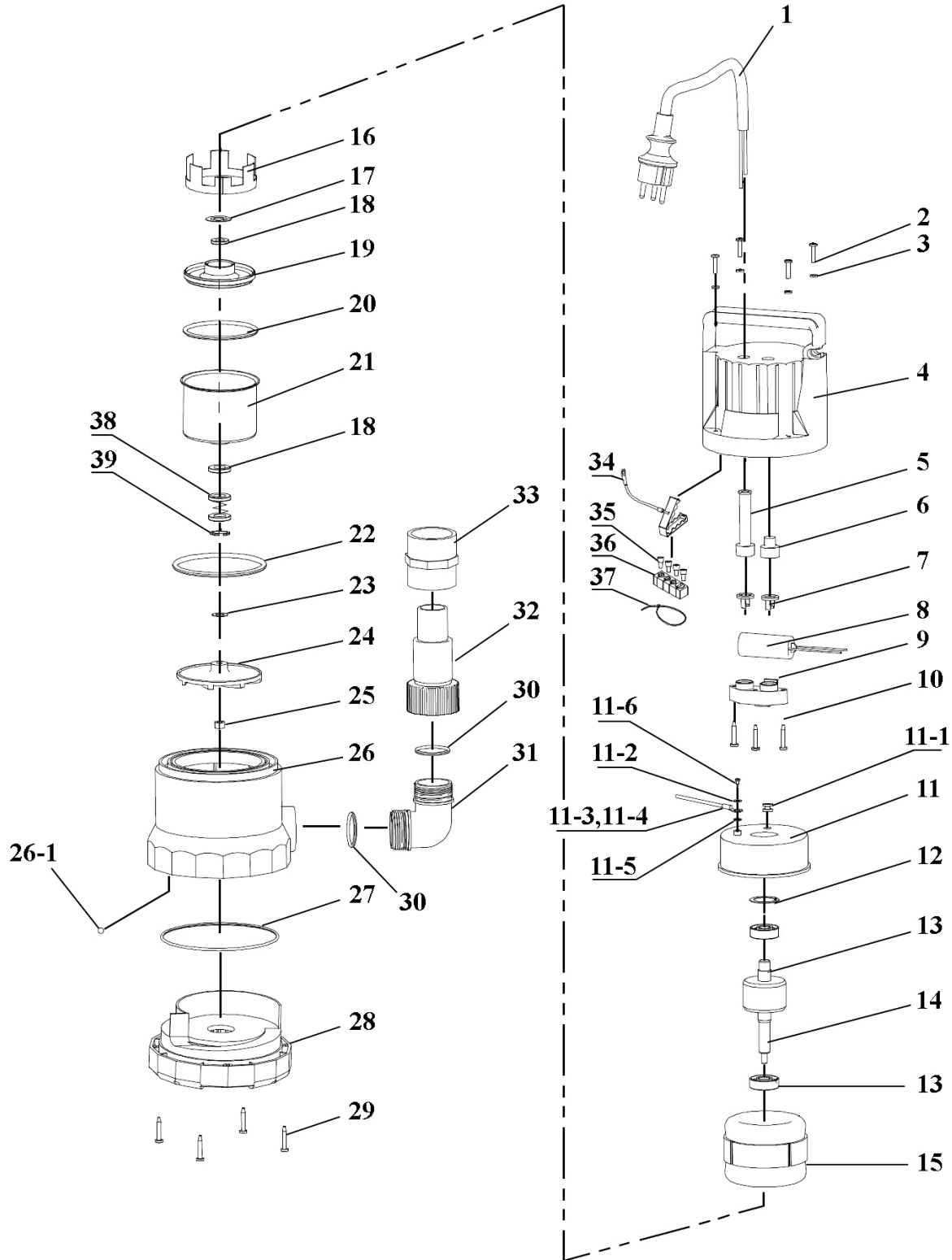

**NOTE:** It is our policy to continually improve products and as such we reserve the right to alter data, specifications and component parts without prior notice.

**IMPORTANT:** No liability is accepted for incorrect use of product.

**WARRANTY:** Guarantee is 12 months from purchase date, proof of which will be required for any claim.

Sealey Group, Kempson Way, Suffolk Business Park, Bury St Edmunds, Suffolk. IP32 7AR



01284 757500



01284 703534



sales@sealey.co.uk



www.sealey.co.uk



Parts Information:  
**Submersible Water Pump 167ltr/min 230V**  
**Model No: WPC150.V2**

1	WP08701001	POWER CABLE
2	WPC150V2.02	SELF-TAPPING SCREW (4.5x30)
3	WP03802031	WASHER
4	WP00302015	REAR PUMP CASING
--	WPC150V2.04-1	HANDLE COVER (NOT SHOWN)
--	WPD235AV2.05B	REAR PUMP HOUSING (NOT SHOWN)
5	WP05201033	CABLE SHEATH
6	WPC250.06	CABLE PLUG
7	WP05602005	CABLE BUCKLE
8	WPC150V2.08	CAPACITOR 8uF
9	WP05501001	CABLE GRIP
10	WP07802018	SELF-TAPPING SCREW
11	WP02602004	ALUMINUM REAR COVER
11.1	WP05202003	WIRE SHEATH
11.2	WPC150V2.11-2	WASHER
11.3	WP08601010	WIRE (GREEN/YELLOW)
11.4	WP04102006	PLATE
11.5	WPC150V2.11-5	WASHER
11.6	WP818	SCREW M4X8
12	WP03801001	WAVE WASHER
13	B/6201ZZ	BEARING 6201ZZ
14	WPC150V2.14	ROTOR
15	WPC150V2.15	STATOR
16	WPC235V2.16	BUSHING
17	WP03802023	WASHER
18	WPC150V2.18	SEAL

Item	Part No.	Description
19	WP04204001	ALUMINUM BUSHING
20	WPC150V2.20	O-RING
21	WPC150V2.21	FRONT COVER
22	WP05101010	O-RING
23	WPC250.23	ADJUSTABLE WASHER
--	WPC250.23-1	ADJUSTABLE WASHER (NOT SHOWN)
24	WPC150V2.24	IMPELLER
25	WPC150V2.25	NUT
26	WP02901010	MAIN PUMP CASING
26.1	WP3086	STEEL BALL
27	WPC250.27	O-RING
28	WPC250.28	BASE
29	WP845I	SELF TAPPING SCREW ST4.2x32
30	WPC150V2.30	O-RING
31	WPC250.31	ELBOW
32	WPC250.32	OUTLET CONNECTOR
33	WPC250.33	FLEXIBLE CONNECTOR
34	WP04105006	GROUND COVER
35	WP04101001	NYLON SAFETY PRESS LINE CAP
35.1	WP04101003	NYLON SAFETY PRESS LINE CAP
36	WP03203012	RUBBER CLIP
37	WP08501001	CABLE TIE
38	WP06101007	MECHANICAL SEAL
39	WPC150V2.39	BLOCK

**NOTE:** It is our policy to continually improve products and as such we reserve the right to alter data, specifications and component parts without prior notice.

**IMPORTANT:** No liability is accepted for incorrect use of product.

**WARRANTY:** Guarantee is 12 months from purchase date, proof of which will be required for any claim.

**Sealey Group**, Kempson Way, Suffolk Business Park, Bury St Edmunds, Suffolk. IP32 7AR



01284 757500



01284 703534



sales@sealey.co.uk



www.sealey.co.uk



Parts Information:  
Submersible Water Pump Automatic 167ltr/  
min 230V  
Model No: WPC150A.V2

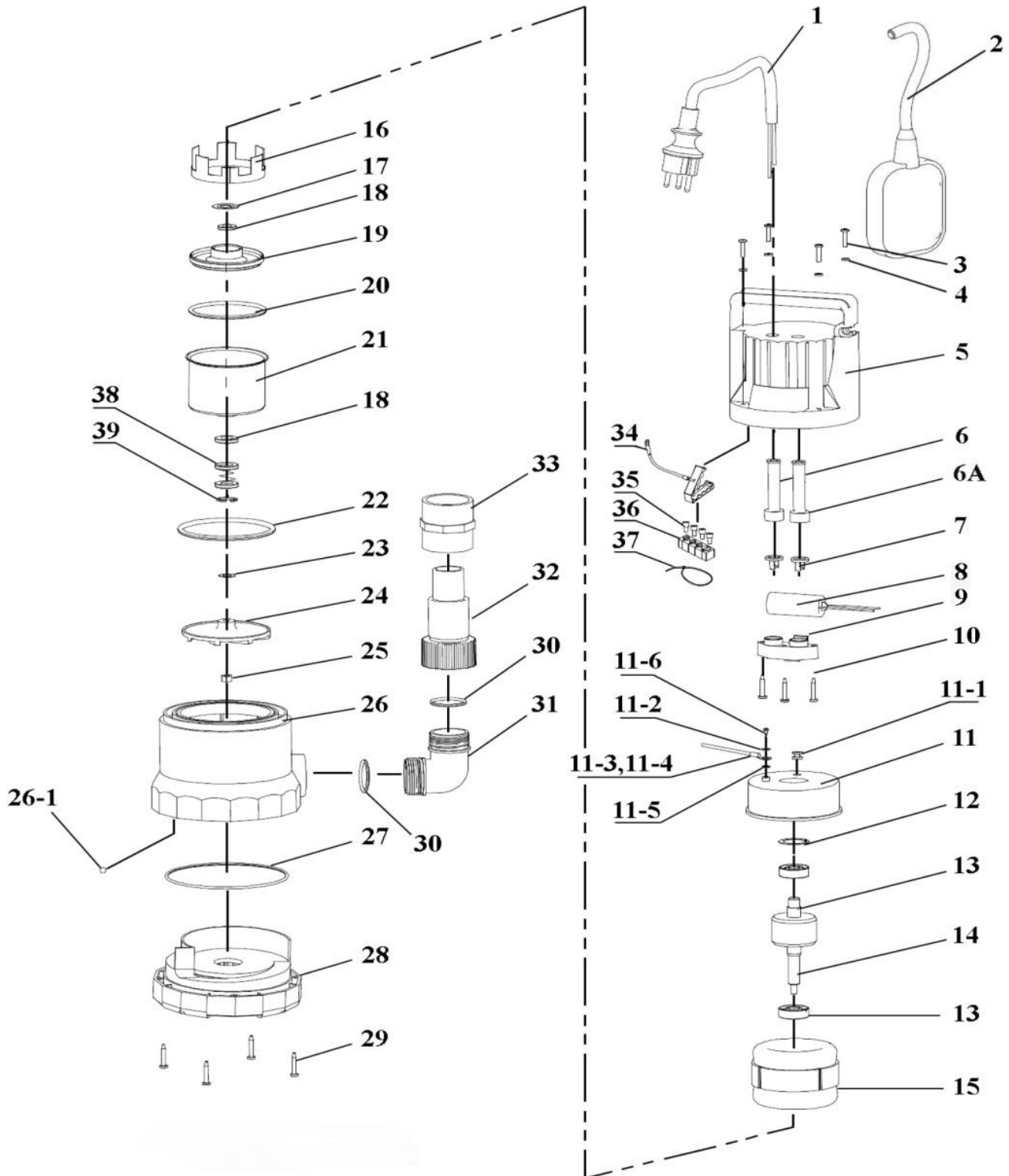

**NOTE:** It is our policy to continually improve products and as such we reserve the right to alter data, specifications and component parts without prior notice.

**IMPORTANT:** No liability is accepted for incorrect use of product.

**WARRANTY:** Guarantee is 12 months from purchase date, proof of which will be required for any claim.

Sealey Group, Kempson Way, Suffolk Business Park, Bury St Edmunds, Suffolk. IP32 7AR



01284 757500



01284 703534



sales@sealey.co.uk



www.sealey.co.uk



Parts Information:  
**Submersible Water Pump Automatic 167ltr/  
min 230V**  
**Model No: WPC150A.V2**

1	WP08701001	POWER CABLE
2	WPC150AV2.02	FLOAT SWITCH
3	WPC150V2.02	SELF-TAPPING SCREW (4.5x30)
4	WP03802031	WASHER
5	WP00302015	REAR PUMP CASING
--	WPC150V2.04-1	HANDLE COVER (NOT SHOWN)
--	WPD235AV2.05B	REAR PUMP HOUSING (NOT SHOWN)
6	WP05201036	CABLE SHEATH
6A	WP05201033	CABLE SHEATH
7	WP05602008	CABLE PRESS PAD
7A	WP05602005	CABLE PRESS PAD
8	WPC150V2.08	CAPACITOR 8uF
9	WP05501001	CABLE GRIP
10	WP07802018	SELF-TAPPING SCREW
11	WP02602004	COVER
11.1	WP05202003	CABLE SHEATH
11.2	WPC150V2.11-2	WASHER
11.3	WP08601010	YELLOW/GREEN WIRE
11.4	WP04102006	WIRE CONNECTING PAD
11.5	WPC150V2.11-5	WASHER
11.6	WP818	SCREW M4X8
12	WP03801001	WAVE WASHER
13	B/6201ZZ	BEARING 6201ZZ
14	WPC150V2.14	ROTOR
15	WPC150V2.15	STATOR
16	WPC235V2.16	BUSHING
17	WP03802023	WASHER

Item	Part No.	Description
18	WPC150V2.18	SEAL
19	WP04204001	ALUMINUM BUSHING
20	WPC150V2.20	O-RING
21	WPC150V2.21	FRONT COVER
22	WP05101010	O-RING
23	WPC250.23	ADJUSTABLE WASHER
--	WPC250.23-1	ADJUSTABLE WASHER (NOT SHOWN)
24	WPC150V2.24	IMPELLER
25	WPC150V2.25	NUT
26	WP02901010	MAIN PUMP CASING
--	WP3086	STEEL BALL (NOT SHOWN)
27	WPC250.27	O-RING
28	WPC250.28	BASE
29	WP845I	SELF TAPPING SCREW ST4.2x32
30	WPC150V2.30	O-RING
31	WPC250.31	ELBOW
32	WPC250.32	OUTLET CONNECTOR
33	WPC250.33	FLEXIBLE CONNECTOR
34	WP04105006	GROUND COVER
35	WP04101001	NYLON SAFETY PRESS LINE CAP
--	WP04101003	NYLON SAFETY PRESS LINE CAP (NOT SHOWN)
36	WP03203012	RUBBER CLIP
37	WP08501001	CABLE TIE
38	WP06101007	MECHANICAL SEAL
39	WPC150V2.39	BLOCK

**NOTE:** It is our policy to continually improve products and as such we reserve the right to alter data, specifications and component parts without prior notice.

**IMPORTANT:** No liability is accepted for incorrect use of product.

**WARRANTY:** Guarantee is 12 months from purchase date, proof of which will be required for any claim.

**Sealey Group**, Kempson Way, Suffolk Business Park, Bury St Edmunds, Suffolk. IP32 7AR



01284 757500



01284 703534



sales@sealey.co.uk



www.sealey.co.uk

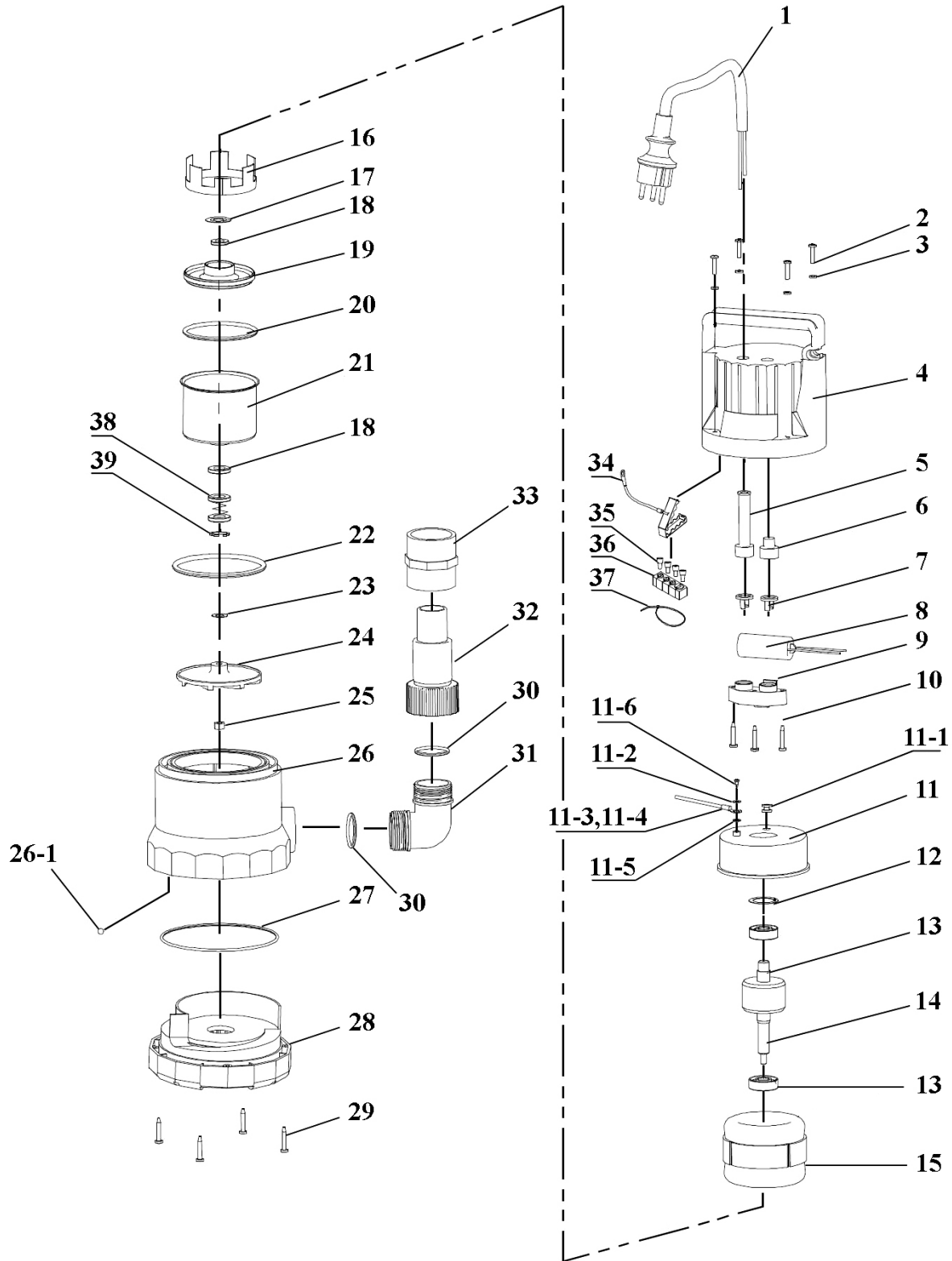

**NOTE:** It is our policy to continually improve products and as such we reserve the right to alter data, specifications and component parts without prior notice.

**IMPORTANT:** No liability is accepted for incorrect use of product.

**WARRANTY:** Guarantee is 12 months from purchase date, proof of which will be required for any claim.



Parts Information:  
**Submersible Water Pump 208ltr/min 230V**  
**Model No: WPC235.V2**

1	WP08701001	POWER CABLE
2	WPC235V2.02	SELF-TAPPING SCREW (4.5x30)
3	WP03802031	WASHER
4	WPC235V2.04	REAR PUMP HOUSING
--	WPC250.04-1	HANDLE COVER (NOT SHOWN)
--	WPD235AV2.05B	REAR PUMP HOUSING (NOT SHOWN)
5	WPC235V2.05	CABLE SHEATH
6	WPC250.06	CABLE PLUG
7	WP05602005	CABLE BUCKLE
8	WPC235V2.08	CAPACITOR 8uF
9	WP05501001	CABLE GRIP
10	WP07802018	SELF-TAPPING SCREW
11	WP02602004	ALUMINUM REAR COVER
11.1	WP05202003	WIRE SHEATH
11.2	WPC235V2.11-2	WASHER
11.3	WP08601010	WIRE (GREEN/YELLOW)
11.4	WP04102006	PLATE
11.5	WPC235V2.11-5	WASHER
11.5	WP818	SCREW M4X8
12	WP03801001	WAVE WASHER
13	B/6201ZZ	BEARING 6201ZZ
14	WPC235V2.14	ROTOR
15	WPC235V2.15	STATOR
16	WPC235V2.16	BUSHING
17	WP03802023	WASHER
18	WPC235V2.18	SEAL

Item	Part No.	Description
19	WP04204001	ALUMINUM BUSHING
20	WPC235V2.20	O-RING
21	WPC235V2.21	FRONT COVER
22	WP05101010	O-RING
23	WPC250.23	ADJUSTABLE WASHER
--	WPC235V2.23	ADJUSTABLE WASHER (NOT SHOWN)
24	WPC235V2.24	IMPELLER
25	WPC235V2.25	NUT
26	WPC235V2.26	PUMP BODY
26.1	WP3086	STEEL BALL
27	WPC250.27	O-RING
28	WPC250.28	BASE
29	WP845I	SELF TAPPING SCREW ST4.2x32
30	WPC235V2.30	O-RING
31	WPC250.31	ELBOW
33	WPC250.32	OUTLET CONNECTOR
33	WPC250.33	FLEXIBLE CONNECTOR
34	WP04105006	GROUND COVER
35	WP04101001	NYLON SAFETY PRESS LINE CAP
--	WP04101003	NYLON SAFETY PRESS LINE CAP (NOT SHOWN)
36	WP03203012	RUBBER CLIP
37	WP08501001	CABLE TIE
38	WP06101007	MECHANICAL SEAL
39	WPC235V2.39	BLOCK

**NOTE:** It is our policy to continually improve products and as such we reserve the right to alter data, specifications and component parts without prior notice.

**IMPORTANT:** No liability is accepted for incorrect use of product.

**WARRANTY:** Guarantee is 12 months from purchase date, proof of which will be required for any claim.

**Sealey Group**, Kempson Way, Suffolk Business Park, Bury St Edmunds, Suffolk. IP32 7AR



01284 757500



01284 703534



sales@sealey.co.uk



www.sealey.co.uk



Parts Information:  
Submersible Water Pump Automatic  
208ltr/min 230V  
Model No: WPC235A.V2

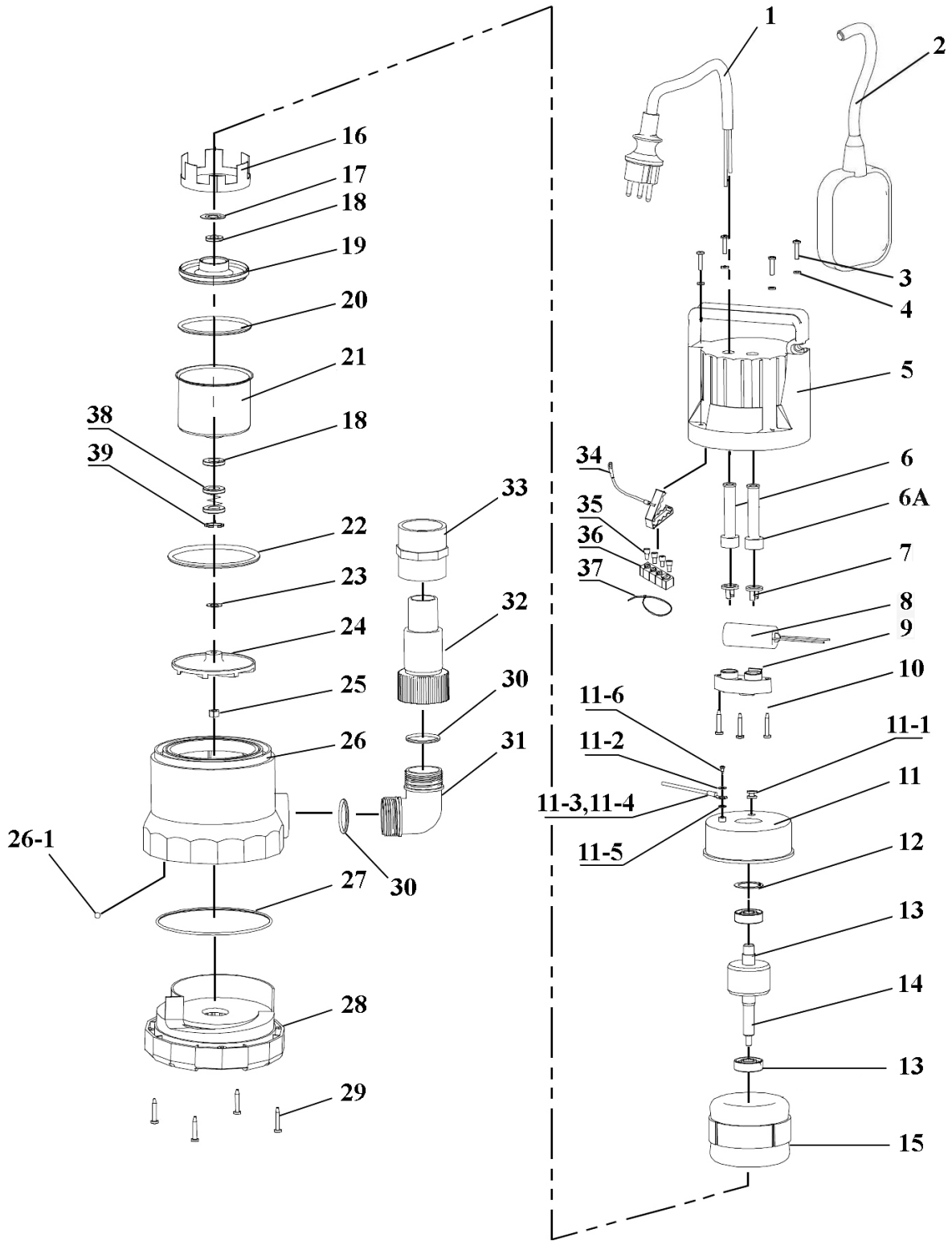

**NOTE:** It is our policy to continually improve products and as such we reserve the right to alter data, specifications and component parts without prior notice.

**IMPORTANT:** No liability is accepted for incorrect use of product.

**WARRANTY:** Guarantee is 12 months from purchase date, proof of which will be required for any claim.

Sealey Group, Kempson Way, Suffolk Business Park, Bury St Edmunds, Suffolk. IP32 7AR



01284 757500



01284 703534



sales@sealey.co.uk



www.sealey.co.uk



Parts Information:  
**Submersible Water Pump Automatic**  
**208ltr/min 230V**  
**Model No: WPC235A.V2**

1	WP08701001	POWER CABLE
2	WPC235AV2.02	FLOAT SWITCH
3	WPC235V2.02	SELF-TAPPING SCREW (4.5x30)
4	WP03802031	WASHER
5	WPC235V2.04	REAR PUMP HOUSING
--	WPC250.04-1	HANDLE COVER (NOT SHOWN)
--	WPD235AV2.05B	REAR PUMP HOUSING (NOT SHOWN)
6	WPC235V2.05	CABLE SHEATH
6A	WP05201036	CABLE SHEATH
7	WP05602008	PAD
7A	WP05602005	CABLE PRESS PAD
8	WPC235V2.08	CAPACITOR 8uF
9	WP05501001	CABLE GRIP
10	WP07802018	SELF-TAPPING SCREW
11	WP02602004	ALUMINUM REAR COVER
11.1	WP05202003	WIRE SHEATH
11.2	WPC235V2.11-2	WASHER
11.3	WP08601010	YELLOW/GREEN WIRE
11.4	WP04102006	WIRE CONNECTING PAD
11.5	WPC235V2.11-5	WASHER
11.6	WP818	SCREW M4X8
12	WP03801001	WAVE WASHER
13	B/6201ZZ	BEARING 6201ZZ
14	WPC235V2.14	ROTOR
15	WPC235V2.15	STATOR
16	WPC235V2.16	BUSHING
17	WP03802023	WASHER

Item	Part No.	Description
18	WPC235V2.18	SEAL
19	WP04204001	ALUMINUM BUSHING
20	WPC235V2.20	O-RING
21	WPC235V2.21	FRONT COVER
22	WP05101010	O-RING
23	WPC250.23	ADJUSTABLE WASHER
--	WPC250.23-1	ADJUSTABLE WASHER (NOT SHOWN)
24	WPC235V2.24	IMPELLER
25	WPC235V2.25	NUT
26	WPC235V2.26	PUMP BODY
--	WP3086	STEEL BALL (NOT SHOWN)
27	WPC250.27	O-RING
28	WPC250.28	BASE
29	WP845I	SELF TAPPING SCREW ST4.2x32
30	WPC235V2.30	O-RING
31	WPC250.31	ELBOW
32	WPC250.32	OUTLET CONNECTOR
33	WPC250.33	FLEXIBLE CONNECTOR
34	WP04105006	GROUND COVER
35	WP04101001	NYLON SAFETY PRESS LINE CAP
--	WP04101003	NYLON SAFETY PRESS LINE CAP (NOT SHOWN)
36	WP03203012	RUBBER CLIP
37	WP08501001	CABLE TIE
38	WP06101007	MECHANICAL SEAL
39	WPC235V2.39	BLOCK

**NOTE:** It is our policy to continually improve products and as such we reserve the right to alter data, specifications and component parts without prior notice.

**IMPORTANT:** No liability is accepted for incorrect use of product.

**WARRANTY:** Guarantee is 12 months from purchase date, proof of which will be required for any claim.

**Sealey Group**, Kempson Way, Suffolk Business Park, Bury St Edmunds, Suffolk. IP32 7AR



01284 757500



01284 703534



sales@sealey.co.uk



www.sealey.co.uk





Parts Information:  
Submersible Water Pump 250ltr/min 230V  
Model No: WPC250

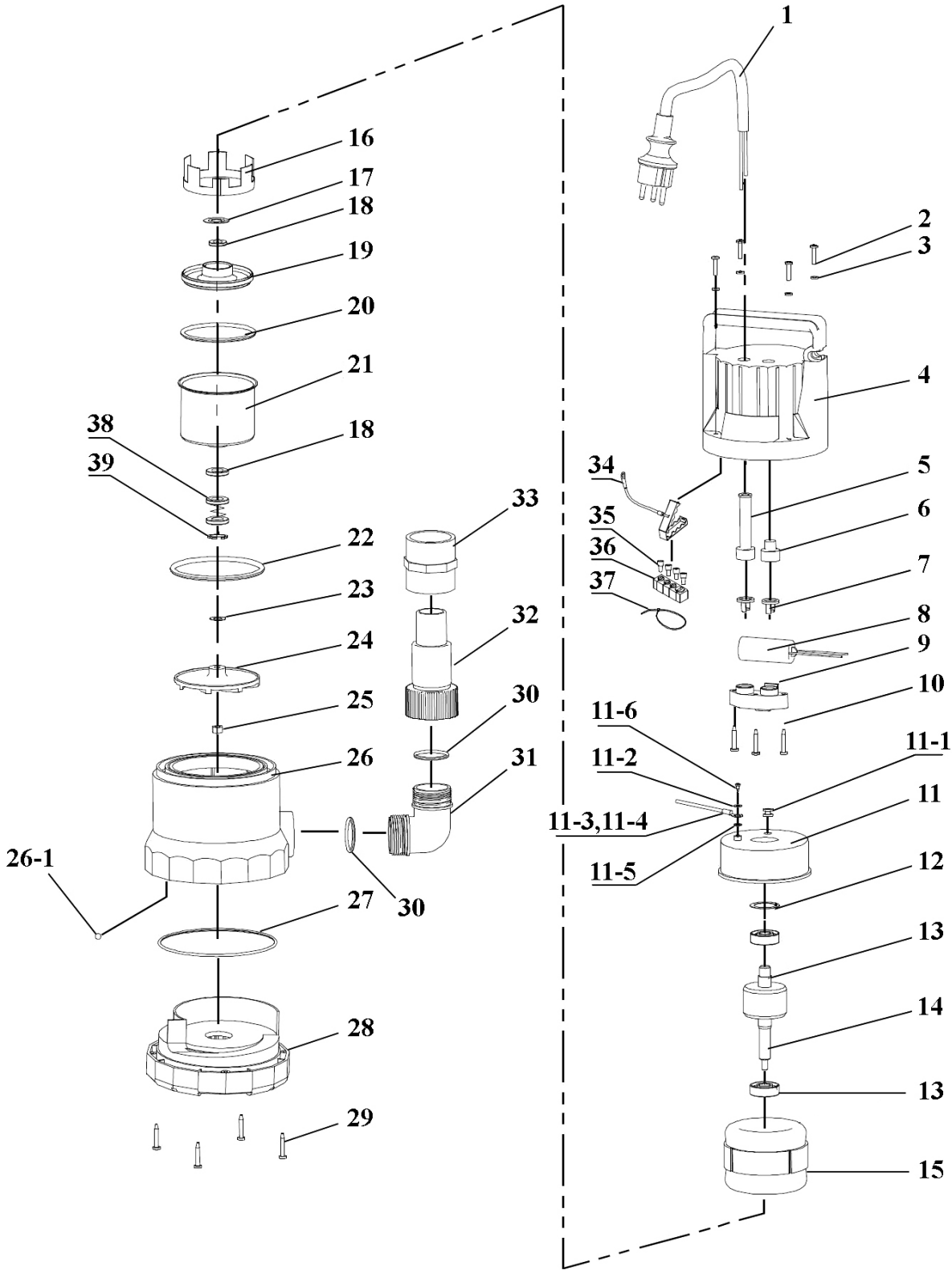

**NOTE:** It is our policy to continually improve products and as such we reserve the right to alter data, specifications and component parts without prior notice.

**IMPORTANT:** No liability is accepted for incorrect use of product.

**WARRANTY:** Guarantee is 12 months from purchase date, proof of which will be required for any claim.

Sealey Group, Kempson Way, Suffolk Business Park, Bury St Edmunds, Suffolk. IP32 7AR



01284 757500



01284 703534



sales@sealey.co.uk



www.sealey.co.uk



Parts Information:  
**Submersible Water Pump 250ltr/min 230V**  
**Model No: WPC250**

1	WP08701001	POWER CABLE
2	WPC250.02	RD HEAD S/T SCREW M4X22
3	FWM4.S	FLAT WASHER M4 SINGLE
4	WPC250.04	REAR PUMP HOUSING
--	WPC250.04-1	HANDLE COVER (NOT SHOWN)
--	WPD235AV2.05B	REAR PUMP HOUSING (NOT SHOWN)
5	WP05201036	CABLE SHEATH
6	WPC250.06	CABLE PLUG
7	WP05602008	CABLE BUCKLE
8	WPC250.08	CAPACITOR 16uF
9	WP05501001	CABLE GRIP
10	WP07802018	SELF-TAPPING SCREW
11	WP02602004	ALUMINUM REAR COVER
11.1	WP05202003	WIRE SHEATH
11.2	WPC250.11-2	WASHER
11.3	WP08601010	WIRE
11.4	WP04102006	PLATE
11.5	WPC250.11-5	WASHER
11.6	WP818	SCREW M4X8
12	WP03801001	WAVE WASHER
13	B/6201ZZ	BEARING 6201ZZ
14	WPC250.14	ROTOR
15	WPC250.15	STATOR
16	WPC250.16	BUSHING
17	WP03802023	WASHER
18	WPC250.18	SEAL

Item	Part No.	Description
19	WP04204001	ALUMINUM BUSHING
20	WPC250.20	O-RING
21	WPC250.21	FRONT COVER
22	WPC250.22	O-RING
23	WPC250.23	ADJUSTABLE WASHER
--	WPC250.23-1	ADJUSTABLE WASHER (NOT SHOWN)
24	WPC250.24	IMPELLER
25	NLN8.S	NYLOC NUT M8 ZINC DIN 985 (SINGLE)
26	WPC250.26	PUMP BODY
26.1	WP3086	STEEL BALL
27	WPC250.27	O-RING
28	WPC250.28	BASE
29	WPC100.V2-16	RD HEAD S/T SCREW M4X30
30	WPC250.30	O-RING
31	WPC250.31	ELBOW
32	WPC250.32	OUTLET CONNECTOR
33	WPC250.33	FLEXIBLE CONNECTOR
34	WP04105006	GROUND COVER
35	WP04101001	NYLON SAFETY PRESS LINE CAP
--	WP04101003	NYLON SAFETY PRESS LINE CAP (NOT SHOWN)
36	WP03203012	RUBBER CLIP
37	WP08501001	CABLE TIE
38	WP06101007	MECHANICAL SEAL
39	WPC250.39	BLOCK

**NOTE:** It is our policy to continually improve products and as such we reserve the right to alter data, specifications and component parts without prior notice.

**IMPORTANT:** No liability is accepted for incorrect use of product.

**WARRANTY:** Guarantee is 12 months from purchase date, proof of which will be required for any claim.

**Sealey Group**, Kempson Way, Suffolk Business Park, Bury St Edmunds, Suffolk. IP32 7AR



01284 757500



01284 703534



sales@sealey.co.uk



www.sealey.co.uk



Parts Information:  
Submersible Water Pump Automatic  
250ltr/min 230V  
Model No: WPC250A

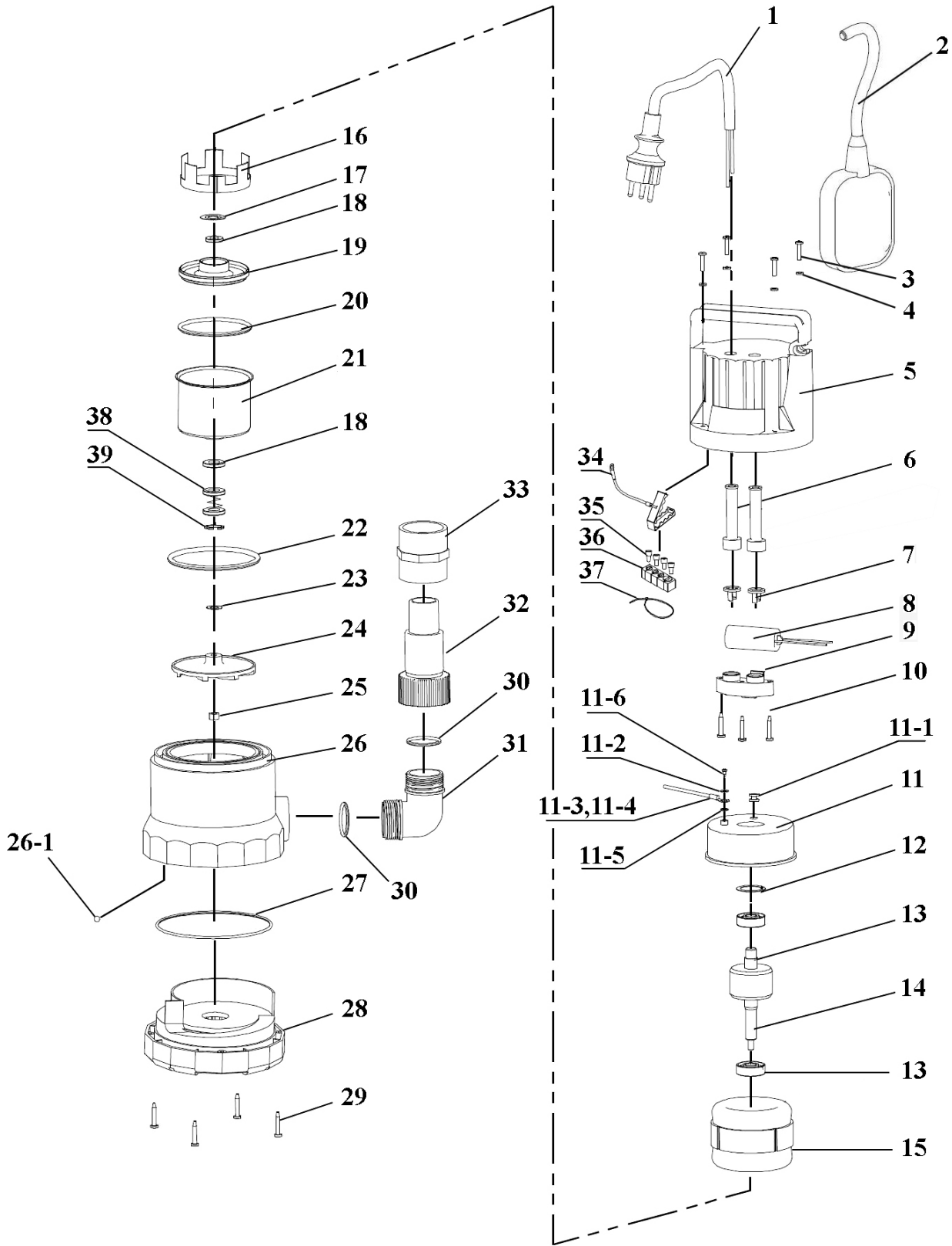

**NOTE:** It is our policy to continually improve products and as such we reserve the right to alter data, specifications and component parts without prior notice.

**IMPORTANT:** No liability is accepted for incorrect use of product.

**WARRANTY:** Guarantee is 12 months from purchase date, proof of which will be required for any claim.

Sealey Group, Kempson Way, Suffolk Business Park, Bury St Edmunds, Suffolk. IP32 7AR



01284 757500



01284 703534



sales@sealey.co.uk



www.sealey.co.uk



Parts Information:  
**Submersible Water Pump Automatic**  
**250ltr/min 230V**  
**Model No: WPC250A**

1	WP08701001	POWER CABLE
2	WPC250A.02	FLOAT SWITCH
3	WPC250.02	RD HEAD S/T SCREW M4X22
4	FWM4.S	FLAT WASHER M4 SINGLE
5	WPC250.04	REAR PUMP HOUSING
--	WPC250.04-1	HANDLE COVER (NOT SHOWN)
--	WPD235AV2.05B	REAR PUMP HOUSING (NOT SHOWN)
6	WP05201036	CABLE SHEATH
7	WP05602008	CABLE BUCKLE
8	WPC250.08	CAPACITOR 16uF
9	WP05501001	CABLE GRIP
10	WP07802018	SELF-TAPPING SCREW
11	WP02602004	ALUMINUM REAR COVER
11.1	WP05202003	WIRE SHEATH
11.2	WPC250.11-2	WASHER
11.3	WP08601010	WIRE
11.4	WP04102006	PLATE
11.5	WPC250.11-5	WASHER
11.6	WP818	SCREW M4X8
12	WP03801001	WAVE WASHER
13	B/6201ZZ	BEARING 6201ZZ
14	WPC250.14	ROTOR
15	WPC250.15	STATOR
16	WPC250.16	BUSHING
17	WP03802023	WASHER
18	WPC250.18	SEAL

Item	Part No.	Description
19	WP04204001	ALUMINUM BUSHING
20	WPC250.20	O-RING
21	WPC250.21	FRONT COVER
22	WPC250.22	O-RING
23	WPC250.23	ADJUSTABLE WASHER
--	WPC250.23-1	ADJUSTABLE WASHER (NOT SHOWN)
24	WPC250.24	IMPELLER
25	NLN8.S	NYLOC NUT M8 ZINC DIN 985 (SINGLE)
26	WPC250.26	PUMP BODY
--	WP3086	STEEL BALL (NOT SHOWN)
27	WPC250.27	O-RING
28	WPC250.28	BASE
29	WPC100.V2-16	RD HEAD S/T SCREW M4X30
30	WPC250.30	O-RING
31	WPC250.31	ELBOW
32	WPC250.32	OUTLET CONNECTOR
33	WPC250.33	FLEXIBLE CONNECTOR
34	WP04105006	GROUND COVER
35	WP04101001	NYLON SAFETY PRESS LINE CAP
--	WP04101003	NYLON SAFETY PRESS LINE CAP (NOT SHOWN)
36	WP03203012	RUBBER CLIP
37	WP08501001	CABLE TIE
38	WP06101007	MECHANICAL SEAL
39	WPC250.39	BLOCK

**NOTE:** It is our policy to continually improve products and as such we reserve the right to alter data, specifications and component parts without prior notice.

**IMPORTANT:** No liability is accepted for incorrect use of product.

**WARRANTY:** Guarantee is 12 months from purchase date, proof of which will be required for any claim.

**Sealey Group**, Kempson Way, Suffolk Business Park, Bury St Edmunds, Suffolk. IP32 7AR



01284 757500



01284 703534



sales@sealey.co.uk



www.sealey.co.uk