

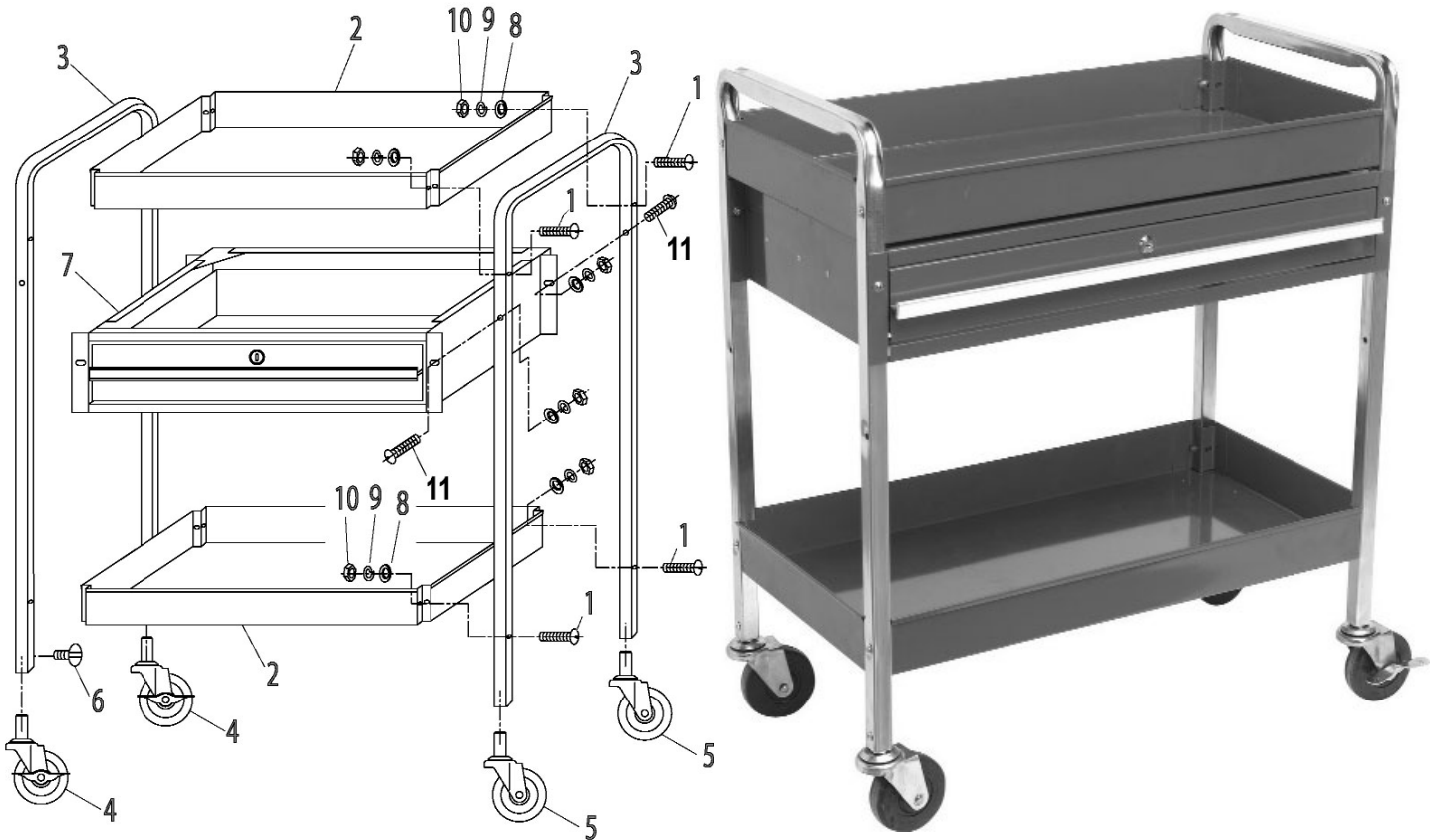

Parts Information:
**Trolley 2-Level Heavy-Duty with Lockable
 Drawer**
Model No: CX101D



Item	Part No.	Description
1	MSP632.S	MACHINE SCREW PAN HEAD PHILLIPS M6x32mm
2	CX101D.02	TRAY
3	CX101D.03	HANDLE
4	CX101D.04	CASTOR WHEEL c/w BRAKE 103X46X11
5	CX101D.05	CASTOR WHEEL 102X39X11
6	CX101D.06	BOLT

Item	Part No.	Description
7	CX101D.07	TOOL CHEST
8	FWM6.S	FLAT WASHER M6 SINGLE
9	SWM6.S	SPRING WASHER M6 ZINC (SINGLE)
10	SN6.S	STEEL NUT M6 ZINC DIN934 (SINGLE)
11	CX101D.11	BOLT M6X40
--	CX101D.12	LOCK & KEY (NOT SHOWN)

NOTE: It is our policy to continually improve products and as such we reserve the right to alter data, specifications and component parts without prior notice.

IMPORTANT: No liability is accepted for incorrect use of product.

WARRANTY: Guarantee is 12 months from purchase date, proof of which will be required for any claim.

Sealey Group, Kempson Way, Suffolk Business Park, Bury St Edmunds, Suffolk. IP32 7AR



01284 757500



01284 703534



sales@sealey.co.uk



www.sealey.co.uk