

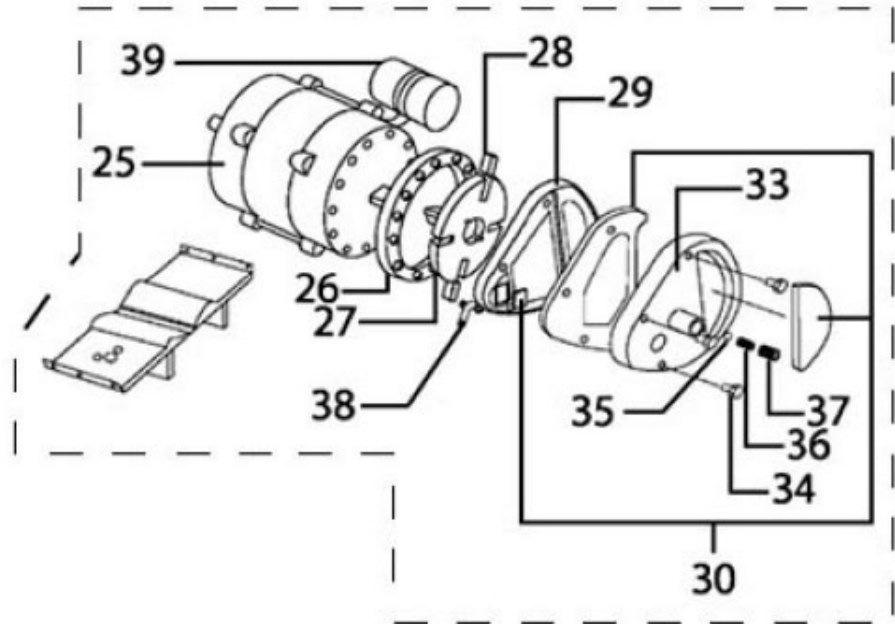

Parts Information:  
**Space Warmer® Paraffin/Kerosene/Diesel Heater 70,000Btu/hr with  
Wheels**  
**Model No: AB7081.V2**

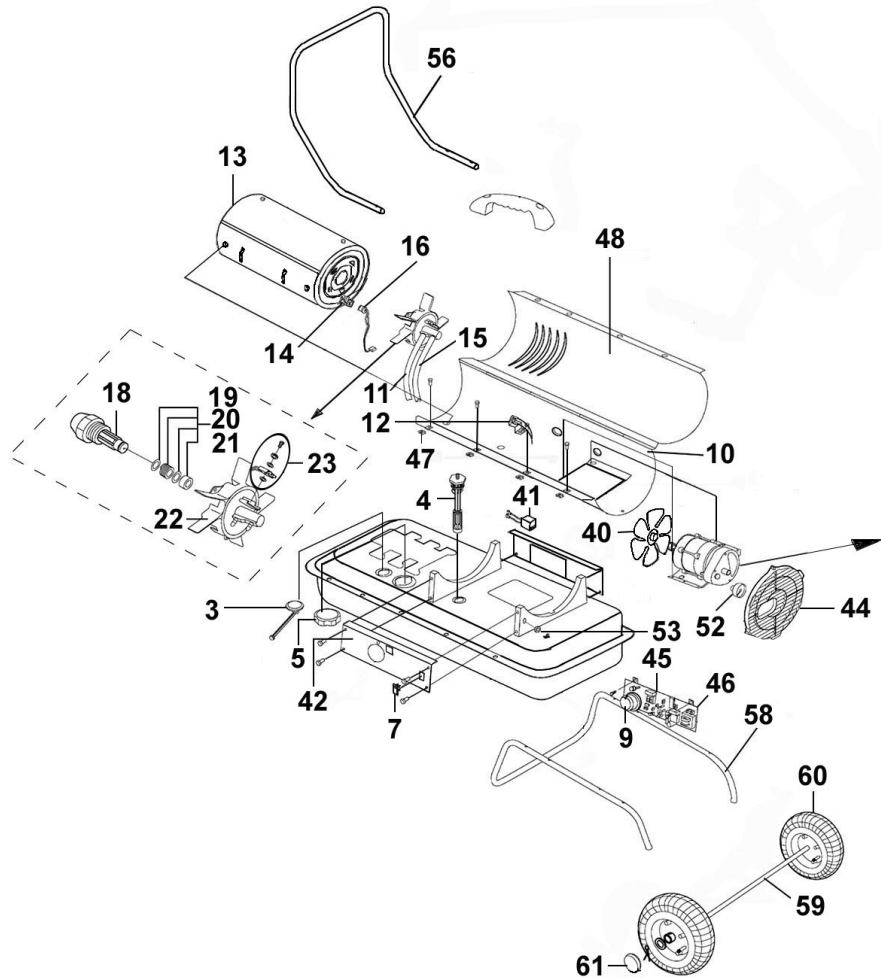

**NOTE:** It is our policy to continually improve products and as such we reserve the right to alter data, specifications and component parts without prior notice.

There may be alternative versions of this product, please contact us should you require this information.

**IMPORTANT:** No liability is accepted for incorrect use of product. Spare parts must be fitted by a competent person

**WARRANTY:** Guarantee is 12 months from purchase date, proof of which will be required for any claim.

Sealey Group, Kempson Way, Suffolk Business Park, Bury St Edmunds, Suffolk. IP32 7AR



01284 757500



01284 703534



sales@sealey.co.uk



www.sealey.co.uk



Parts Information:  
**Space Warmer® Paraffin/Kerosene/Diesel  
 Heater 70,000Btu/hr with Wheels  
 Model No: AB7081.V2**

Item	Part No.	Description
3	P70-007-0100	Fuel Gauge Assembly
4	P70-003-0100	Fuel filter Assembly
5	P70-006-0120	Fuel Cap Assembly (inc Gasket)33mm dia
7	P75-012-0110	switch, On/Off Rocker 3a/250v
9	P70-031-0100	Thermostat Control Knob
10	P70-001-0902	Lower Cover
11	P70-035-0200	Air Hose 6mm x 10.6mm x 370mm
12	P70-019-0100	thermal Cut Out Switch (B080)
13	P70-011-0200	Combustion Chamber
14	P70-010-0101	Flame Sensor Bracket
15	P70-036-0200	Fuel Hose, Rubber (6mm ID x 12mm OD x 150mm Long)
16	P70-016-0100	Flame Sensor
18	P70-015-0200	Nozzle - Delavan 70 k
19	P70-015-010	Nozzle Sea lWasher
20	P70-015-0102	Nozzle Seal Spring Dia 10.8mm
21	P70-015-0103	Nozzle Sleeve
22	P70-014-0101	Burner Head
23	P70-052-0100	Spark Plug
25	P70-021-0501	Motor (Internal 230v 50hz)
26	P70-020-0401	Pump body
27	P70-022-0200	Rotor Kit 5/8" (c/w Vanes/Clip)
28	P70-022-0202	Rotor Blade Set
29	P70-020-0102	End Pump Cover
30	P70-054-0100	Filter kit
33	P70-020-0103	End Filter Cover

Item	Part No.	Description
34	P70-055-0100	Plug/Pump Adjust Kit
35	SB-6.4	Steel Ball 6.4mm
36	P70-020-0105	Spring
37	P70-020-0106	Adjusting Screw
38	P70-014-0104	Nipple
39	P70-020-0221	Capacitor c65r 12uf 50/60hz 70x40
40	P70-024-0200	Fan
41	P70-037-0100	Ignitor (2015 part)
42	P70-008-0201	Right side cover (AB7081 only)
44	P70-016-0700	Fan Guard
45	P70-027-0200	Main PCB Assembly
46	P70-027-0101	Fuse Glass 5amp250v 5x20
47	P70-001-0105	Clip Nut
48	P70-001-0903	Upper Cover (AB7081 only)
52	P70-025-0100	Air Pressure Gauge
53	P70-033-0100	Cord Bushing
56	P70-042-0105	Front Handle
58	P70-041-0170	Wheel Support Frame
59	P70-041-0500	Axle (AB7081 only) (47.5cm)
60	P70-041-0160	Wheel, Pneumatic (D:155 W:45 B:12)
61	P70-041-0104	Wheel Cap
--	P70-056-0301	Harware Kit (AB7081 only)(Not Shown)
--	P70-032-0100	Cord Wrap(Not Shown)
--	P70-001-0104	Hinge Pin(Not Shown)
--	P70-015-0100	Nozzle - Delavan 45k(Not Shown)

**NOTE:** It is our policy to continually improve products and as such we reserve the right to alter data, specifications and component parts without prior notice. There may be alternative versions of this product, please contact us should you require this information.

**IMPORTANT:** No liability is accepted for incorrect use of product. Spare parts must be fitted by a competent person

**WARRANTY:** Guarantee is 12 months from purchase date, proof of which will be required for any claim.

**Sealey Group**, Kempson Way, Suffolk Business Park, Bury St Edmunds, Suffolk. IP32 7AR



01284 757500



01284 703534



sales@sealey.co.uk



www.sealey.co.uk