



RACKING UNIT WITH 5 SHELVES

MODEL NO: **AP6500**

Thank you for purchasing a Sealey product. Manufactured to a high standard, this product will, if used according to these instructions, and properly maintained, give you years of trouble free performance.

IMPORTANT: PLEASE READ THESE INSTRUCTIONS CAREFULLY. NOTE THE SAFE OPERATIONAL REQUIREMENTS, WARNINGS & CAUTIONS. USE THE PRODUCT CORRECTLY AND WITH CARE FOR THE PURPOSE FOR WHICH IT IS INTENDED. FAILURE TO DO SO MAY CAUSE DAMAGE AND/OR PERSONAL INJURY AND WILL INVALIDATE THE WARRANTY. KEEP THESE INSTRUCTIONS SAFE FOR FUTURE USE.



Refer to instructions

1. SAFETY

1.1. GENERAL SAFETY

- WARNING!** Ensure Health & Safety, and local authority regulations are adhered to when assembling and using these shelves.
- ✓ Locate shelves in a suitable area where they will not be an obstruction.
- ✓ Keep the general area clean, uncluttered and ensure there is adequate lighting.
- WARNING!** Erect shelves on a level and solid surface such as concrete.
- ✓ Keep children and unauthorised persons away from the storage area.
- ✗ **DO NOT** use the shelves for any purpose other than that for which they are designed.
- ✗ **DO NOT** site the shelves out of doors.
- ✗ **DO NOT** get the shelves wet or use in damp or wet locations or areas where there is condensation.
- ✗ **DO NOT** clean the shelf supports with any solvents which may damage the coated surface.
- ✓ Ensure that the shelves are properly assembled before loading them with heavy items.
- ✓ Where possible the unit should be fixed to the wall with suitable fixings
- ✓ Place heavier items on the lower shelves.
- ✓ Where possible heavier items should be evenly distributed across the shelves.

2. INTRODUCTION

Fully painted steel frame with five MDF shelves. No nuts and bolts means no tools required to assemble. Clips together in minutes. Two piece uprights allow use as a single bay rack or split into two separate shelf systems or workstations.

3. SPECIFICATION

Model No: AP6500
 Capacity: 2500kg
 Nett Weight: 35.39Kg
 Overall Size (W x D x H): 900 x 425 x 1800mm
 Shelf Capacity: 500kg

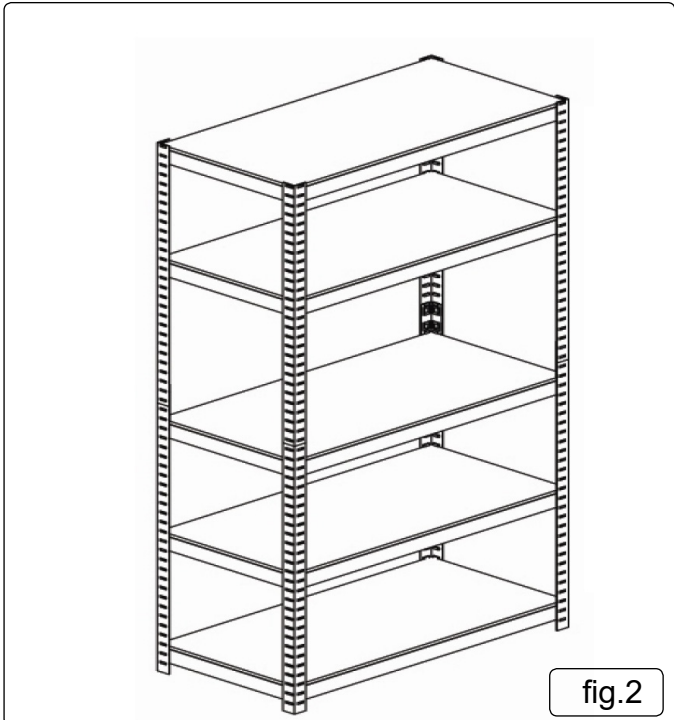
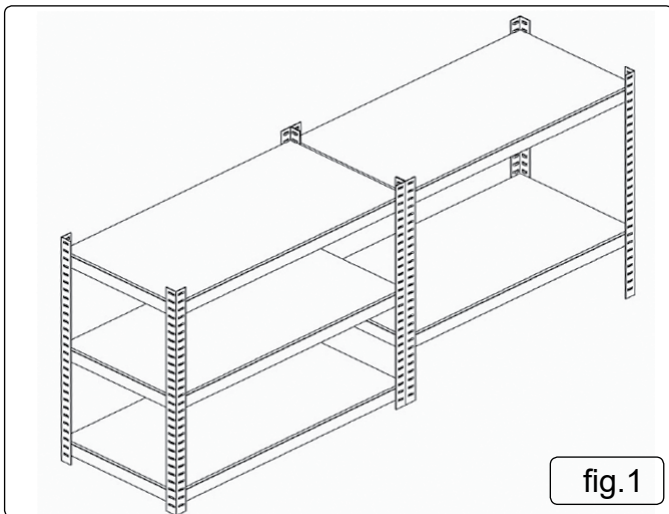

4. CONTENTS

- 4.1. Carefully unpack the product and check the contents as detailed in Fig.3. Should any items be missing or damaged contact your Sealey Stockist.

5. ASSEMBLY

- 5.1. We recommend that this shelving unit be assembled by two people. A rubber mallet or a hammer and a piece of wood can be used to aid assembly. **DO NOT** use a hard faced hammer directly on the beams as this will damage their surface finish. Make sure that the shelf support tabs are in line with the leg angle slots. If the tabs and slots are not lining up **DO NOT** use force as this may damage the tabs. If the tabs are out of line bend them slightly to line up with the slots.

5.2. SINGLE BAY RACKING

See Fig.4. Support two upright angle posts (A) in a vertical position. Join them together at the base using a short step beam (C). Tap the beam at either end, close to each angle post to ensure that the tabs are seated in the slots.

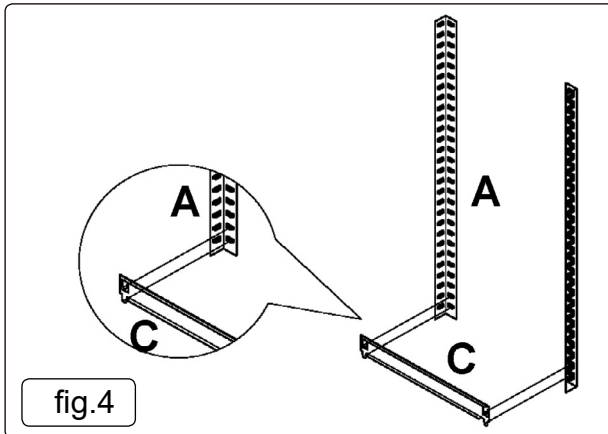

fig.4

- 5.3. See Fig.5. Continue to assemble the complete bottom frame in the order indicated below in Fig.5 starting with a long step beam (B). Ensure that each step beam is facing upwards. Tap the beam at either end, close to each angle post to ensure that the tabs are seated at the bottom of the slots.

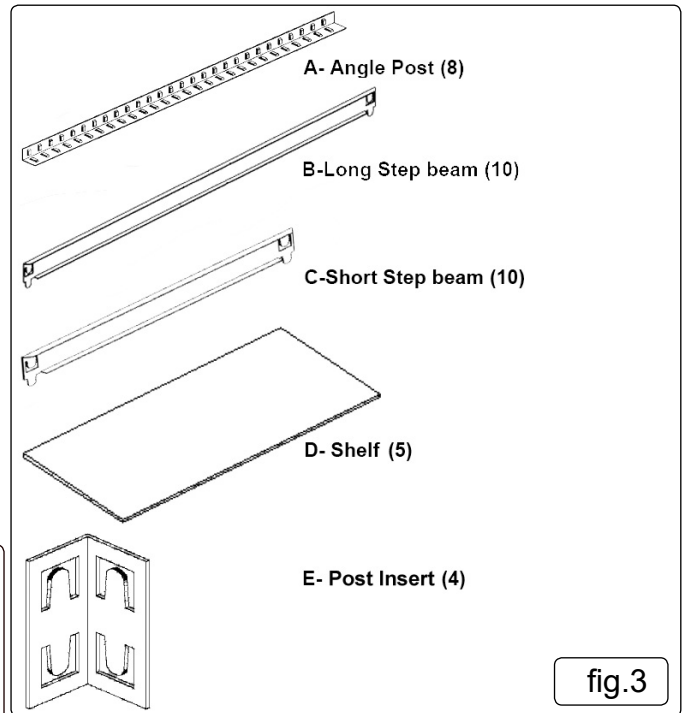

fig.3

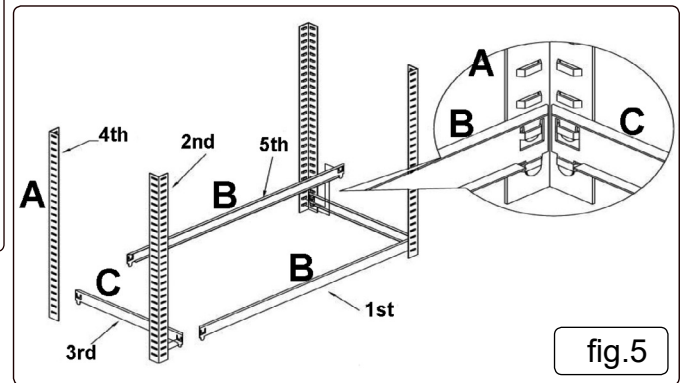

fig.5

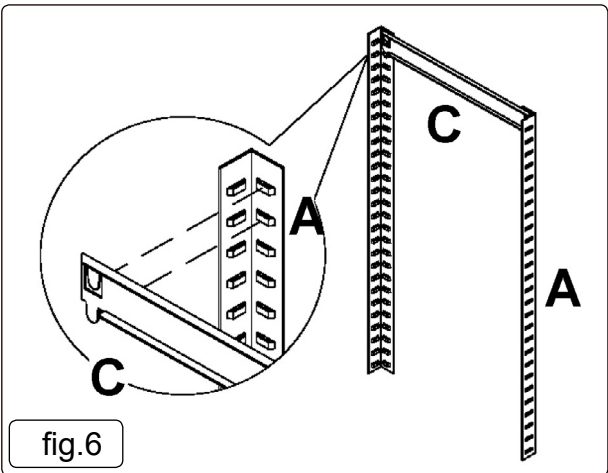

fig.6

- 5.4. See Fig.6. Now make up an upper end frame by connecting two angle posts together at the top with a short step beam (C). Tap the beam at either end to ensure that the tabs are properly seated in the slots. Make up a second upper end frame using the remaining two angle posts and a short step beam.
- 5.5. See Fig.7. Take the 4 post inserts (E) and push them into the top of the four angle posts of the bottom frame assembly. Now join the two upper end frames to the bottom frame by mounting each frame onto the post inserts as shown below.

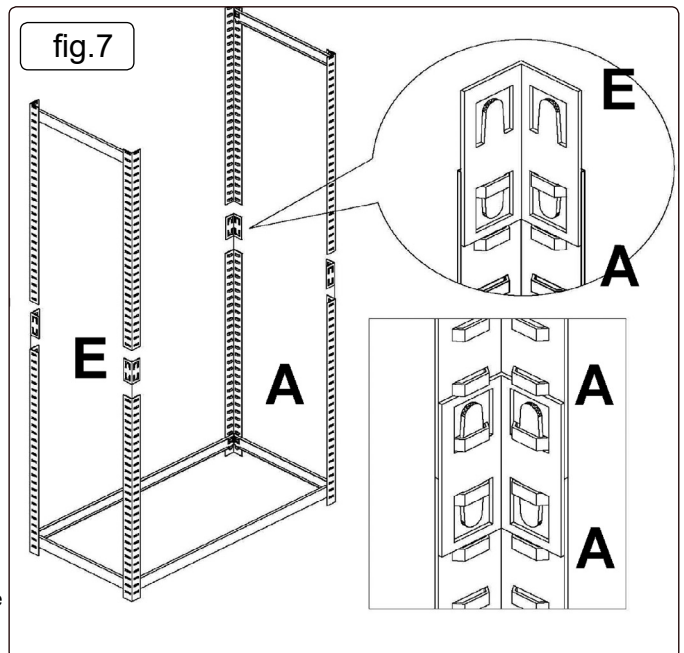
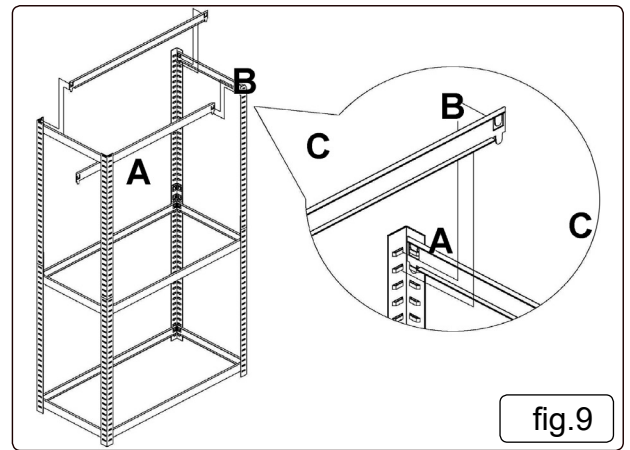
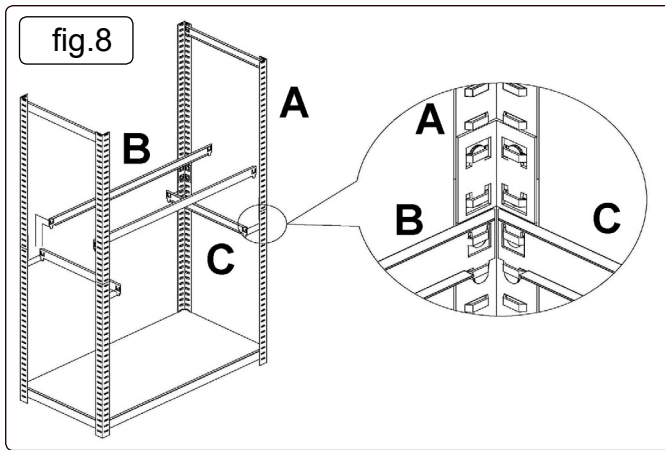
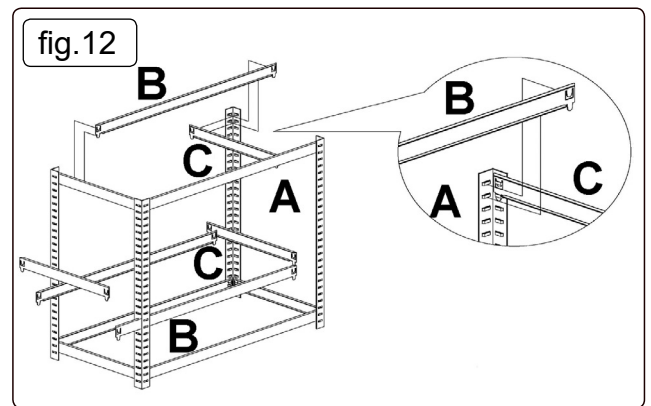
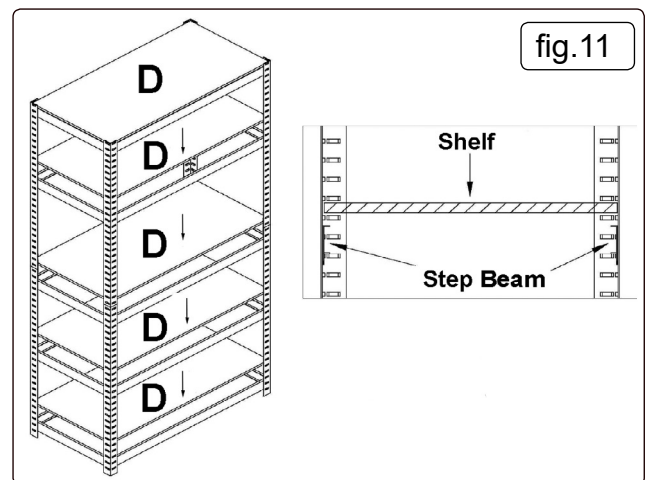
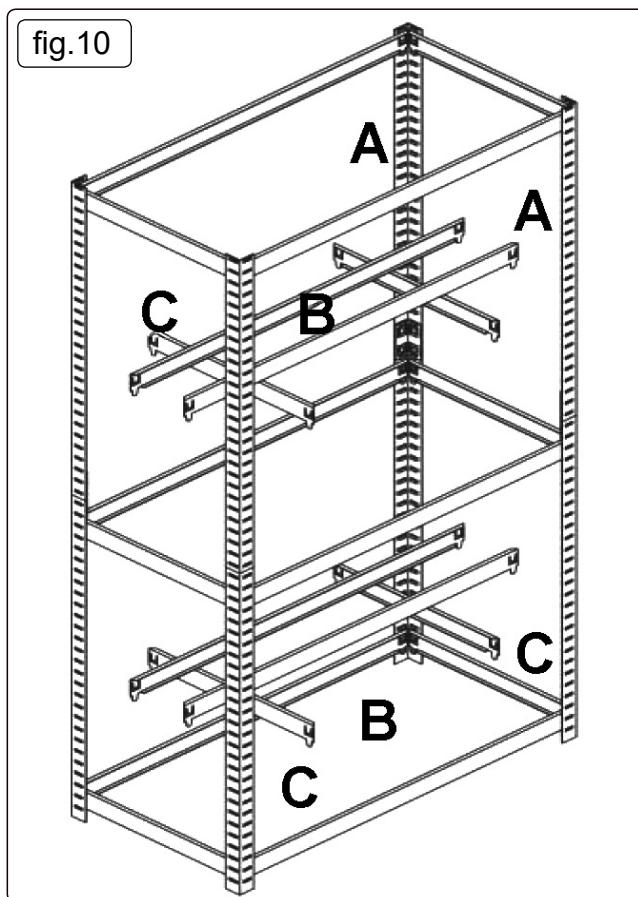

fig.7



- 5.6. **See Fig.8.** Now stabilise the frame assembly by inserting a shelf support halfway up the frame that joins together the upper and lower parts of the frame. As each step beam is added ensure that the top tabs are inserted into the bottom slots of the upper frame and the lower tabs are inserted into the top slots of the bottom frame as shown below. Tap the beams at either end to ensure that the tabs are properly seated into the slots.
- 5.7. **See Fig.9.** Now stabilise the top part of the frame by adding two long step beams (B) to make a shelf support at the top of the frame as shown in Fig.9. Ensure that the beams are the right way up. Tap the beams at either end to ensure that the tabs are properly seated into the slots.



- 5.8. **See Fig.10.** Build one shelf support in the top half of the frame and one shelf support in the bottom half of the frame at the heights required. Ensure that the beams are the right way up. Tap the beams at either end to ensure that the tabs are properly seated into the slots.
- 5.9. **See Fig.11.** Lay a shelf 'D' in between the step beams at each level created (See lower detail in Fig.11).
- 5.10. **HALF HEIGHT WORKSTATION.**
See Fig.12. Follow steps 4.2 and 4.3 to create a bottom frame with four 'A' posts attached. Using two long step beams (B) and two short step beams (C) insert a shelf support level at the top of the angle posts (A). Tap the beams at either end, close to each angle post to ensure that the tabs are seated in the slots. Insert another shelf support level at the desired height within the frame using additional long and short step beams and ensure that the tabs are seated in the slots.

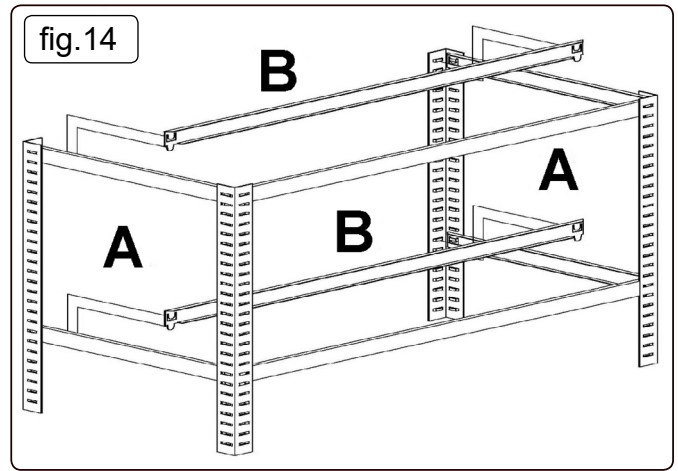
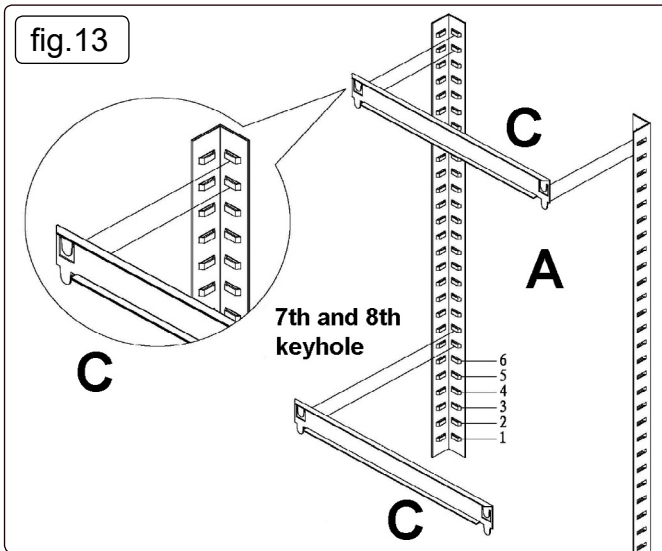

- 5.11. **See Fig.13.** Now start to build the second low level unit by making up two end frames as shown in Fig.13. One short step beam (C) should be fixed at the top of the angle posts and the other short step beam (C) should be fixed at the 7th and 8th slots up from the bottom of the angle posts as shown below. Ensure that each step beam is facing upwards. Tap the beam at either end, close to each angle post to ensure that the tabs are seated at the bottom of the slots.
- 5.12. **See Fig.14.** Join the two end frames together using the four remaining long step beams as shown below. Ensure that each step beam is facing upwards. Tap the beams at either end, close to each angle post to ensure that the tabs are seated at the bottom of the slots.
- 5.13. **See Fig.15.** Lay the shelves into position between the step beams as shown above.
- 5.14. **See Fig.16.** Place the two units end to end as shown below.

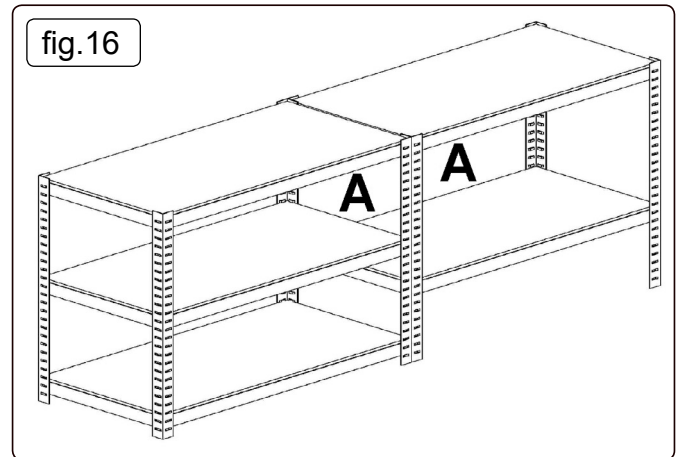
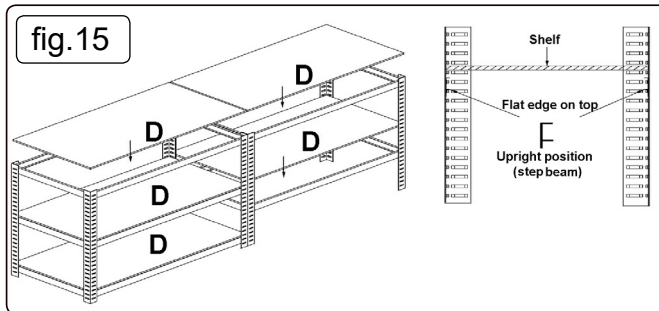

Parts support is available for this product. To obtain parts, please log on to www.sealey.co.uk, email sales@sealey.co.uk or telephone 01284 757500



ENVIRONMENT PROTECTION

Recycle unwanted materials instead of disposing of them as waste. All tools, accessories and packaging should be sorted, taken to a recycling centre and disposed of in a manner which is compatible with the environment. When the product becomes completely unserviceable and requires disposal, drain any fluids (if applicable) into approved containers and dispose of the product and fluids according to local regulations.

Note: It is our policy to continually improve products and as such we reserve the right to alter data, specifications and component parts without prior notice.

Important: No Liability is accepted for incorrect use of this product.

Warranty: Guarantee is 12 months from purchase date, proof of which is required for any claim.

Sealey Group, Kempson Way, Suffolk Business Park, Bury St Edmunds, Suffolk. IP32 7AR



01284 757500



01284 703534



sales@sealey.co.uk



www.sealey.co.uk