



INSTRUCTIONS FOR

# COIL SPRING COMPRESSOR RESTRAINT SYSTEM

MODEL NO: **RE23RS**

Thank you for purchasing a Sealey product. Manufactured to a high standard, this product will, if used according to these instructions, and properly maintained, give you years of trouble free performance.

**IMPORTANT:** PLEASE READ THESE INSTRUCTIONS CAREFULLY. NOTE THE SAFE OPERATIONAL REQUIREMENTS, WARNINGS & CAUTIONS. USE THE PRODUCT CORRECTLY AND WITH CARE FOR THE PURPOSE FOR WHICH IT IS INTENDED. FAILURE TO DO SO MAY CAUSE DAMAGE AND/OR PERSONAL INJURY AND WILL INVALIDATE THE WARRANTY. KEEP THESE INSTRUCTIONS SAFE FOR FUTURE USE.



Refer to instructions



Wear full face protection



Wear protective gloves



Wear safety footwear



Wear protective clothing

## 1. SAFETY

### 1.1. GENERAL SAFETY.

- WARNING!** Ensure Health & Safety, local authority, and general workshop practice regulations are adhered to when using this equipment.
- WARNING!** Wear approved safety hands, face and eye protection (full face visor is essential).
- WARNING! TRAPPING DANGER** – Keep hands and fingers away from the spring and compressing jaws in use.
- ✓ Keep the work area clean, uncluttered and ensure there is adequate lighting.
- ✓ Maintain correct balance and footing. Ensure the floor is not slippery and wear non-slip shoes.
- ✓ Remove ill-fitting clothes. Remove ties, watches, rings, other loose jewellery. Contain and/or tie back long hair.
- ✓ Wear appropriate protective clothing (leather gauntlets and leather apron for example).
- ✓ Familiarise yourself with the applications, limitations and potential hazards of the compression spring restraint.
- ✗ **DO NOT** allow untrained persons to use the compression spring restraint.

### 1.2. PRE OPERATIONAL SAFETY.

- ✓ Strut and Spring Compression station should be securely bolted to the workshop floor before use.
- ✗ **DO NOT** operate spring compressor if parts are damaged or missing as this may cause failure and/or personal injury.
- ✓ Before commencing compression of spring, ensure coils of the spring are seated securely in the jaws of the compressor and cannot slide out during compression.
- ✓ Always fit the restraining chain around strut and spring (ensure the restraining chain is not trapped in the coils of the spring as compressed).
- ✓ Always fit the coil spring compressor restraint system.

### 1.3. OPERATIONAL SAFETY.

- ✓ When applying compression to the spring, always stand to one side of the unit.
- ▲ **DANGER!** Stop compressing the spring as soon as the top cap of shock absorber is no longer under load . Never allow coils to touch each other.
- ✓ Before attempting to remove top cap nut, always use a tool to test if the compression has been relieved. **DO NOT** use your hands/fingers to test for strut to spring forces.
- ✓ We recommend the use of purpose made strut tools to remove the top-nut from the shock piston.
- ✓ Once compressed, and the strut removed, we recommend releasing the tension on the spring. **DO NOT** leave the spring under compression in the machine unattended and **DO NOT** leave in compression for prolonged periods, i.e. overnight.
- ✓ Before releasing the compression ensure that the top strut-nut is securely fastened to the maker's tolerance.
- ✓ Release the compression slowly keeping your hands and fingers away from the spring assembly.
- ✓ Be sure that the tension on the spring is fully controlled by the strut assembly before removing it from the jaws of the compressor.

### 1.4. POST OPERATIONAL SAFETY.

- ✓ When not in use, clean and store the spring compressor including restraint in a safe, dry, childproof location.
- ✓ Maintain the spring compressor and restraint in good condition. Replace or repair damaged parts. Use genuine parts only. Unauthorised parts may be dangerous and will invalidate the warranty.

## 2. INTRODUCTION

Safety restraint system designed for use with Model No's RE231, RE2311 and RE232 Coil Spring Compressors. Quickly installed and fast and simple to operate in use.

RE231/RE2311/RE232 Not included.

## 3. SPECIFICATION

Assembled weight: .....4kg  
Envelope: ..... 645mm x 365mm  
Restraint rod diameter: .....8mm  
Pillar adaptor size: ..... 60mm x 60mm  
Pinch knob: .....M8

Item no	Description	Qty
1	Pillar adaptor bar	1
2	Pivot spindle	1
3	Plain washer 12 dia	2
4	Hexagon stiff nut M12	2
5	Side restraint hoop right hand	1
6	Side restraint hoop left hand	1
7	Inner restraint hoop	1
8	Intermediate restraint hoop	1
9	Intermediate restraint hoop	1
10	Outer restraint hoop	1
11	Pinch knob M8 X 16	1

#### 4. ASSEMBLY

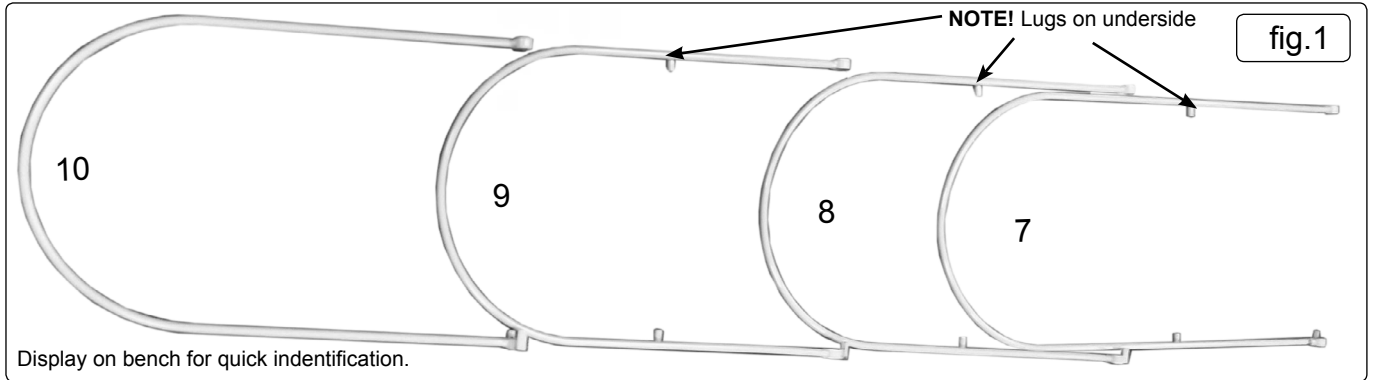

4.1. Empty contents of packaging and display on a bench top to identify and check for missing or damaged parts. In the unlikely event of missing or damaged parts, consult your Sealey Dealer immediately.

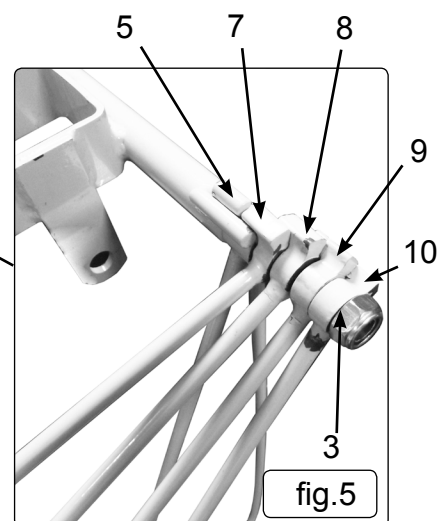
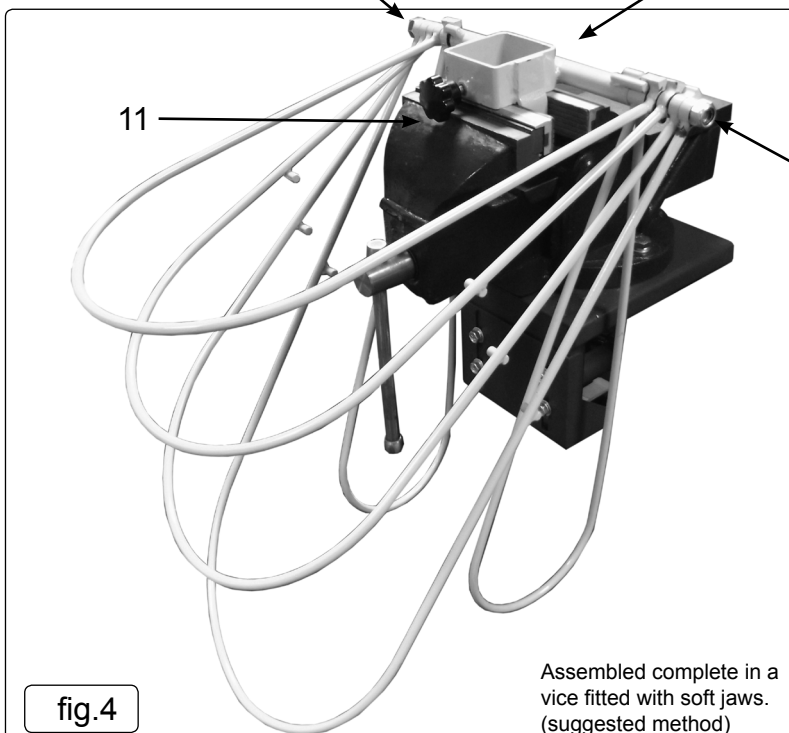
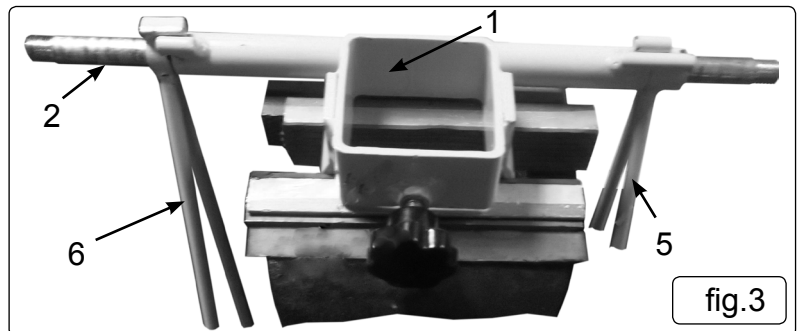
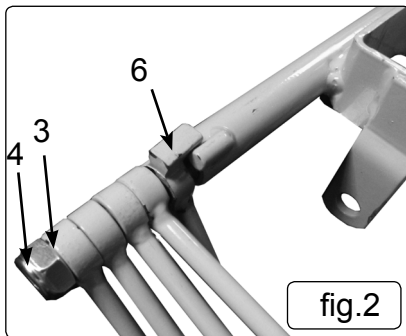

## 4.2. Sequence of assembly

- 4.2.1. Align (items 5, 1 and 6) as shown in fig.3, then pass the pivot spindle (item 2) through all three items with equal projection. Correct orientation is critical. Note (item 5) has a longer boss than (item 6) which makes it easier to identify, both are assembled with the lug projecting inboard. Orientation of (Item 1) is clearly shown by the position of the tapped hole for the pinch knob (item 11).
- 4.2.2. Spring (item 7) over ends of pivot spindle paying particular attention to the position of the lug on the boss shown in fig.5. **DO NOT** over bend the loop when fitting over spindle, this note also applies when fitting (items 8, 9 and 10).
- 4.2.3. Spring (item 8) over ends of pivot spindle paying particular attention to the position of the lug on the boss shown in fig.5.
- 4.2.4. Spring (item 9) over ends of pivot spindle paying particular attention to the position of the lug on the boss shown in fig.5.
- 4.2.5. Spring (item 10) over ends of pivot spindle paying particular attention to the position of the lug on the boss shown in fig.5.
- 4.2.6. Place washer (item 3) at each end of spindle and wind on hexagon stiff nuts (item 4) with equal engagement, without clamping the assembly. All loops to pivot freely under their own weight, limited only by the lugs.
- 4.2.7. Fit pinch knob (item 11) until flush with inside face of bracket (without protrusion).

## 4.3. Fitting to Sealey RE231, RE2311 and RE232 Coil Spring Compressors

- 4.3.1. Read these instructions in conjunction with RE231, RE2311 or RE232 spring compressor instructions. As explained in section 1; always fit the restraining chain around strut and spring fig.3 (single restraint). Strut and spring compression station should be securely bolted to the workshop floor before use.
- 4.3.2. Offer complete assembly as shown in fig.4 on to the vertical column of the spring compressor.
- 4.3.3. With the pinch knob, clamp the assembly at the desired height such that incremental holes in the column align with holes in the restraint bracket lugs. **DO NOT** over-tighten deforming pillar or bracket. This height position is determined by the position of the spring being compressed.
- 4.3.4. Finally insert a M12 X 75 bolt through the restraint bracket lugs and column; retain with a M12 hexagon nut.

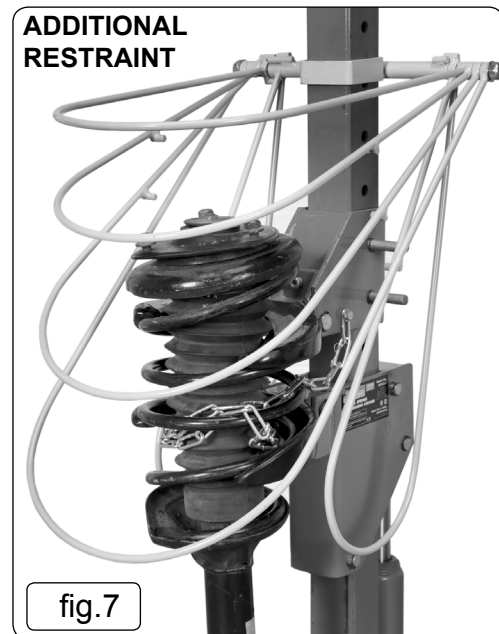

## 5. OPERATION

- 5.1. All the loops of the restraint system, except item 5, can be readily swept up and away from the work area. These loops go beyond the vertical to a self supported leaning position. Item 5 swept path is limited by a mechanical stop.

## 6. MAINTENANCE

- 6.1. The robust nature of the restraint system means that it only requires cleaning after use with a lightly oiled cloth.
- 6.2. Check freedom of loop sweep, which should result from the cleaning/lubricating process in 6.1.
- 6.3. Replace immediately any part that is or appears to be damaged.



### Environmental Protection

Recycle unwanted materials instead of disposing of them as waste. All tools, accessories and packaging should be sorted, taken to a recycling centre and disposed of in a manner which is compatible with the environment. When the product becomes completely unserviceable and requires disposal, drain off any fluids (if applicable) into approved containers and dispose of the product and the fluids according to local regulations.

**NOTE:** It is our policy to continually improve products and as such we reserve the right to alter data, specifications and component parts without prior notice.

**IMPORTANT:** No liability is accepted for incorrect use of this product.

**WARRANTY:** Guarantee is 12 months from purchase date, proof of which will be required for any claim.



Sole UK Distributor, Sealey Group.  
Kempson Way, Suffolk Business Park,  
Bury St. Edmunds, Suffolk.  
IP32 7AR



01284 757500



01284 703534



[www.sealey.co.uk](http://www.sealey.co.uk)



[sales@sealey.co.uk](mailto:sales@sealey.co.uk)