



# PNEUMATIC BRAKE & CLUTCH BLEEDER

MODEL NO: VS821

Thank you for purchasing a Sealey product. Manufactured to a high standard, this product will, if used according to these instructions, and properly maintained, give you years of trouble free performance.

**IMPORTANT:** PLEASE READ THESE INSTRUCTIONS CAREFULLY. NOTE THE SAFE OPERATIONAL REQUIREMENTS, WARNINGS & CAUTIONS. USE THE PRODUCT CORRECTLY AND WITH CARE FOR THE PURPOSE FOR WHICH IT IS INTENDED. FAILURE TO DO SO MAY CAUSE DAMAGE AND/OR PERSONAL INJURY AND WILL INVALIDATE THE WARRANTY. KEEP THESE INSTRUCTIONS SAFE FOR FUTURE USE.



Refer to instruction manual



Wear eye protection

## 1. SAFETY

- WARNING!** Familiarise yourself with the application and limitations, as well as any potential hazards, of this product. Ensure that Health and Safety, local authority and general workshop practice regulations are adhered to when using.
  - DO NOT** use pressure reservoir, or its ancillaries if damaged.
  - DO NOT** use the pressure reservoir to perform a task for which it is not designed.
  - DO NOT** allow untrained persons to use the pressure vessel.
  - DO NOT** use when tired or under the influence of drugs, alcohol or intoxicating medication.
  - Use approved parts and approved spare parts only.
  - Maintain in a good and clean condition for the best and safest performance.
  - Ensure that the ignition key of the vehicle being worked on is removed, to prevent inadvertent engine cranking.
  - If the vehicle to be worked on is raised, ensure that it is adequately supported with axle stands or ramps and wheel chocks.
  - Wear approved eye protection. A full range of personal safety equipment is available from your Sealey stockist.
  - Wear suitable clothing to avoid snagging. **DO NOT** wear jewellery and tie back long hair.
  - Keep children and unauthorised persons away from the work area.
  - Keep work area clean and tidy and free from unrelated materials.
  - Ensure the work area has adequate lighting.
- 1.1. BRAKE FLUID PRECAUTIONS**
- Always read and comply with the warnings on the brake fluid container.
  - Wear eye protection and keep skin contact to a minimum. If brake fluid enters eyes rinse with plenty of water and seek medical advice. If swallowed seek medical advice immediately.
  - WARNING!** Brake fluid is flammable - keep away from sources of ignition, including hot surfaces e.g. exhaust manifold.
  - WARNING!** Brake fluid will damage paintwork. Any spillage should be flushed with water immediately.
  - Always read and comply with the warnings on the brake fluid container.
  - WARNING! DO NOT** pollute the environment by allowing uncontrolled discharge of fluids. Dispose of waste liquids in accordance with local authority regulations.
  - After use, clean equipment and store in a cool, dry, childproof area.

## 2. INTRODUCTION

Professional one man brake and clutch bleeder that uses air from the vehicle tyre. Reservoir holds 1.5ltr of hydraulic fluid - flush the entire system with one fill without the risk of running the reservoir dry. Maximum pressure of 30psi makes the unit suitable with ABS systems. Features a fluid shut off valve to prevent accidental spillage and air pressure release valve. Fitted with Ø45mm cap with 90° angled connector which is suitable for most European models. For other applications order optional Brake Reservoir Cap 45mm Straight Connector - Model No. VS820SA (see fig.6) or Universal Adaptor - VS820UA (see fig.5).

## 3. SPECIFICATION

Model no ..... VS821  
 Capacity ..... 1.5ltr  
 Weight ..... 0.77kg

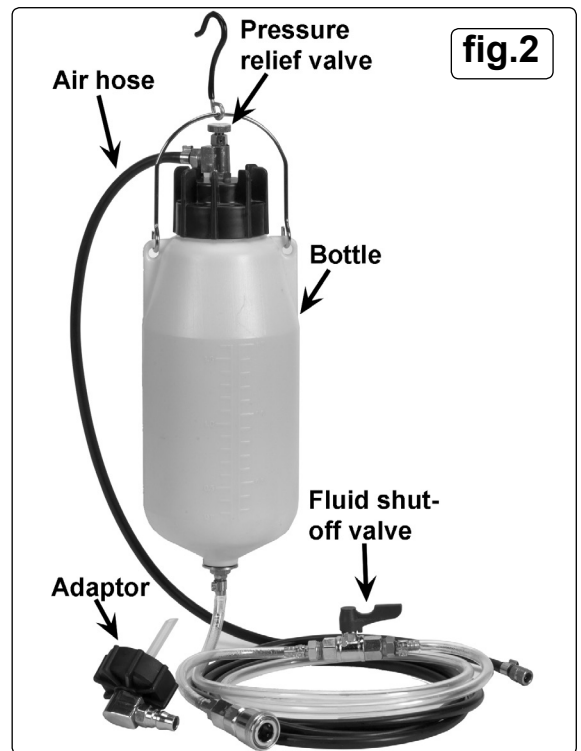
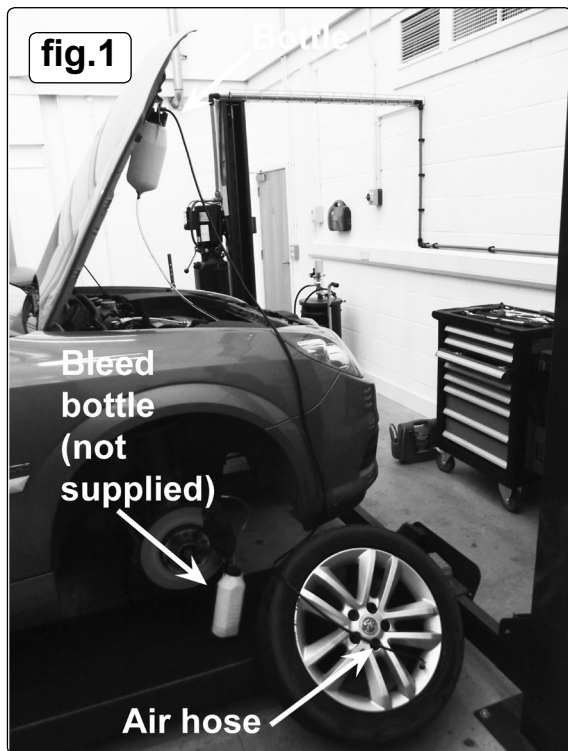

## 4. OPERATION

### 4.1. BRAKE BLEEDING PROCEDURE

4.1.1. Refer to the vehicle manufacturer's instructions for brake bleeding and wheel sequence before proceeding. If no specific instructions from the vehicle manufacturer exist, follow the instructions detailed below.

- **WARNING! Familiarise yourself with the hazards of brake fluid - read manufacturer's instructions on the container.**

**NOTE:** Ensure that the brakes are adjusted before proceeding with bleeding the brakes.

4.1.2. For vehicles fitted with servo assisted brakes, pump the brake pedal two or three times with the engine switched off to evacuate the air from the servo.

4.1.3. Remove the reservoir cap from the vehicle's brake master cylinder, select and fit the master cylinder reservoir adaptor or universal adaptor to the vehicle and couple the clear hose of the automatic brake bleeder (see figs.3, 5 and 6). Make sure the fluid shut-off valve is in the closed position, see fig.3.

4.1.4. Adjust the tyre pressure, of one of the vehicle's tyres, or use a spare wheel, to a maximum of 30 psi and connect the automatic brake bleeder, (see fig.1).

4.1.5. Pressure test the bottle with no brake fluid to ensure that the bottle has no leaks and then release the pressure, by disconnecting from the tyre then releasing the pressure relief valve on top of the bottle (see fig.2). Fill the pressure bottle with new clean brake fluid.

- **WARNING! DO NOT** overtighten the pressure bottle cap. Check that the seal is correctly seated in the cap before use and screw onto the pressure bottle until contact with the seal is achieved, tighten no more than 1/8th of a turn after this contact point.

4.1.6. Ensure that the pressure relief valve (fig.2) on the top of the bottle is in the closed position (screwed fully clockwise), hang under the open bonnet and connect the air hose to the tyre. Open fluid shut off valve. Check to ensure there are no leaks.

**NOTE:** The 30 psi quoted is as a guide only, pressures as low as 10 psi can successfully bleed the brakes.

4.1.7. Starting from the bleed nipple furthest away from the master cylinder, attach a bleed tube and place the other end into a suitable container. Alternatively, use Sealey Brake Bleeder Bottle VS0212. Loosen the bleed nipple (fig.4) to allow the old brake fluid to flow into the container, when the fluid is clean and free from air re-tighten the nipple. Repeat the operation for the remaining bleed nipples in the sequence recommended by the manufacturer.

**NOTE:** Ensure that the pressure bottle does not run out of brake fluid, if topping up is required, disconnect from the tyre, and release the pressure release valve, before replenishing the brake fluid.

4.1.8. When the bleeding operation is complete, disconnect from the tyre and close fluid shut off valve **BEFORE** removing from the brake master cylinder.

If required top up the brake fluid in the reservoir (master cylinder) to the maximum level and replace the original reservoir cap.

4.1.9. Re-pressurise the tyre to its normal operating pressure.

**NOTE:** When brake bleeding and/or fluid changing is complete, test the action of the brake pedal to ensure that the brakes are working and are not spongy before using the vehicle on the road.

### 4.2. TANDEM MASTER CYLINDER BRAKING SYSTEMS

4.2.1. Some vehicles require two lines to be bled simultaneously (normally one front and one rear), in this situation open both bleed nipples.

### 4.3. UNCOMMON BRAKE SYSTEMS

4.3.1. In some cases the master cylinder outlet is below the inlet, this may require pumping the pedal once or twice in conjunction with the pressure bleed to remove any trapped pockets of air. Alternatively the vehicle can be jacked up to raise the outlet.

### 4.4. CLUTCH BLEEDING PROCEDURE

4.4.1. Refer to the relevant vehicle manufacturer's instructions for clutch bleeding procedure. If no specific instructions from the vehicle manufacturer exist, the same procedures as for brake bleeding should be followed.

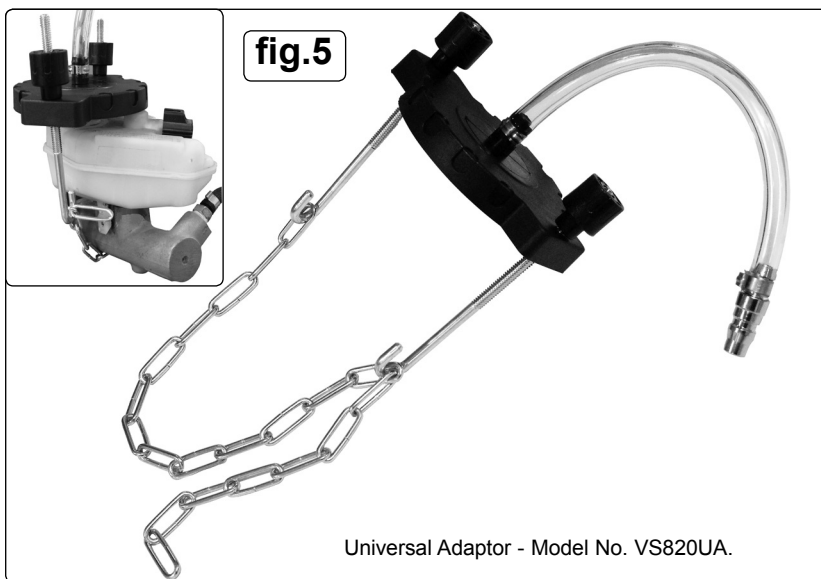
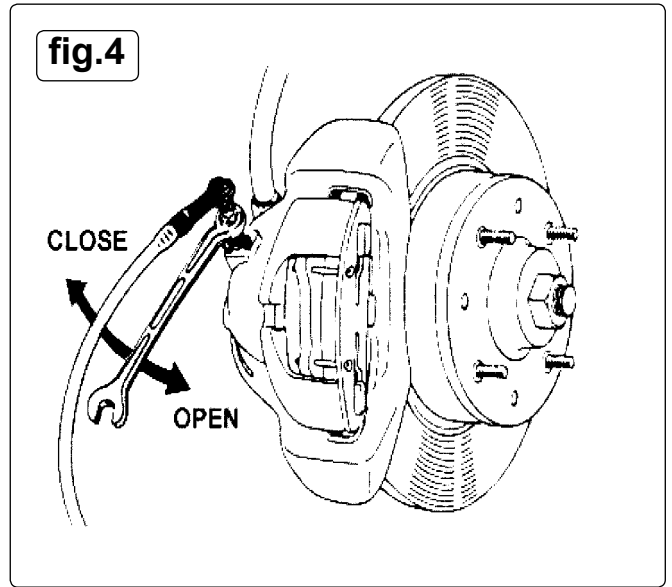
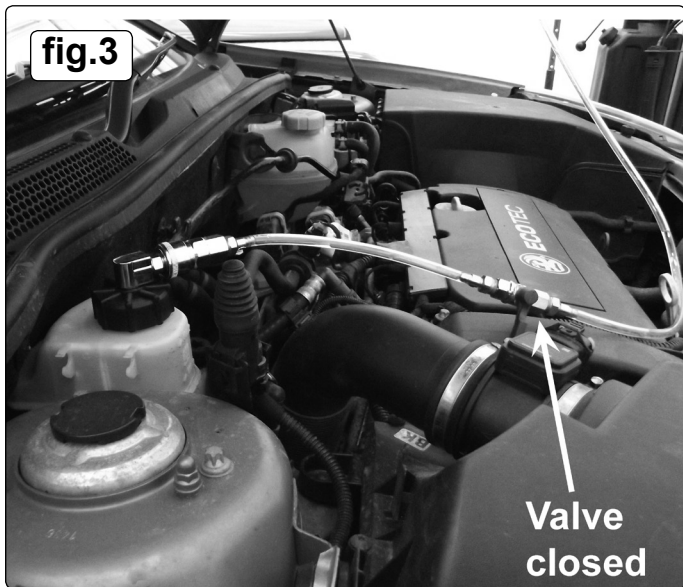

## 5. MAINTENANCE

- 5.1. Ensure that the unit is de-pressurised before carrying out any maintenance and drain all fluids from the pressure bottle and tubes. Clean up any spilt brake fluid and wipe down with a clean cloth. Store in a clean, dry and childproof location.



### ENVIRONMENT PROTECTION

Recycle unwanted materials instead of disposing of them as waste. All tools, accessories and packaging should be sorted, taken to a recycling centre and disposed of in a manner which is compatible with the environment. When the product becomes completely unserviceable and requires disposal, drain any fluids (if applicable) into approved containers and dispose of the product and fluids according to local regulations.

**Note:** It is our policy to continually improve products and as such we reserve the right to alter data, specifications and component parts without prior notice.

**Important:** No Liability is accepted for incorrect use of this product.

**Warranty:** Guarantee is 12 months from purchase date, proof of which is required for any claim.

Sealey Group, Kempson Way, Suffolk Business Park, Bury St Edmunds, Suffolk. IP32 7AR

☎ 01284 757500

📠 01284 703534

✉ sales@sealey.co.uk

🌐 www.sealey.co.uk