

DRAPER
Expert

20V BRUSHLESS 1/2" MID-TORQUE

IMPACT WRENCH



55929 - XP20IW1/2.300 SPARE PARTS DRAWING

XP20
MULTI-TOOL BATTERY SYSTEM

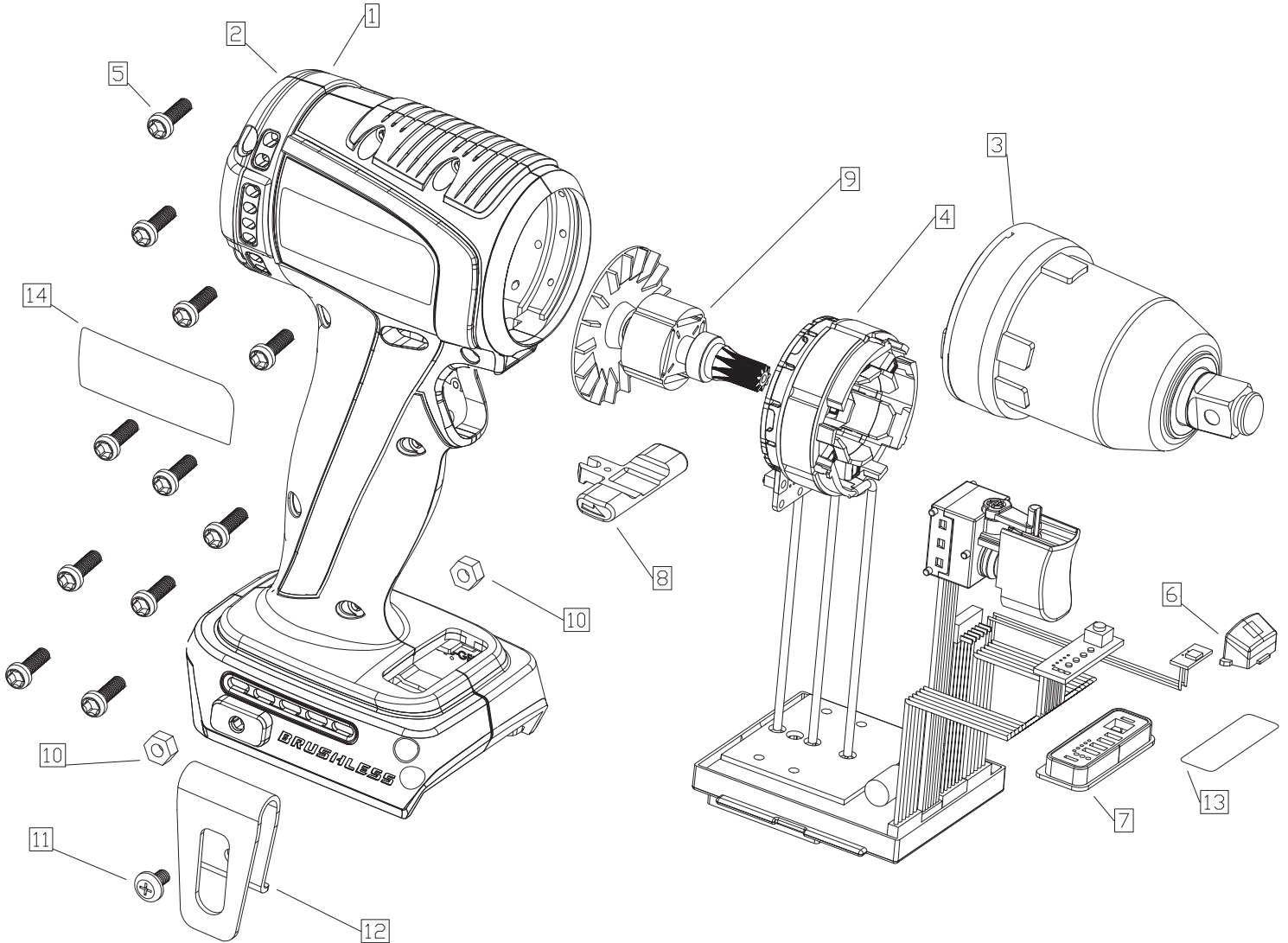

KEY No.	PART No.	STOCK No.	DESCRIPTION
1	YXP20IW1/23-1	98827	Right Housing (Ecopro Blue)
2	YXP20IW1/23-2	98828	Left Housing (Ecopro Blue)
3	YXP20IW1/23-3	98829	Gear Box Assembly 1/2", Retainer+Hole
4	YXP20IW1/23-4	98831	Motor Stator Assembly with Controller
5	YXP20IW1/23-5	98832	Screw, 3*16, Black (set)
6	YXP20IW1/23-6	98833	Cover for LED Light
7	YXP20IW1/23-7	98834	Speed/Torque Selector

KEY No.	PART No.	STOCK No.	DESCRIPTION
8	YXP20IW1/23-8	98835	Forward/Reverse Control Button
9	YXP20IW1/23-9	98837	Motor Rotor Assembly (5010)
10	YXP20CD135-11	98819	Nut, M4 (set)
12	YXP20CD135-15	98825	Belt Hook & screw assembly

Helpline: +44 (0) 23 8049 4344 Sales Desk: +44 (0) 23 8049 4333 General Enquiries: +44 (0) 23 8026 6355 internet: drapertools.com email: sales@drapertools.com